



# Cheshire Residence

7165 E Mercer Way

Mercer Island, WA 98040

## Stormwater Site Plan

June 27, 2025

The information contained in this report was prepared by and under the direct supervision of the undersigned:



**Laurie J. Pfarr, P.E.**  
**LPD Engineering, PLLC**  
1932 1<sup>st</sup> Ave, Suite 500  
Seattle, WA 98101  
(206) 725-1211

Owner:

**Derek and Eileen Cheshire**  
7165 E Mercer Way  
Mercer Island, WA 98040



# CHESHIRE RESIDENCE STORMWATER SITE PLAN TABLE OF CONTENTS

PROJECT OVERVIEW .....	1
MINIMUM REQUIREMENTS .....	3
OFFSITE ANALYSIS .....	2
PERMANENT STORMWATER CONTROL PLAN.....	6
CONSTRUCTION STORMWATER POLLUTION PREVENTION PLAN (SWPPP) .....	9

## FIGURES

- Figure 1: Vicinity Map
- Figure 2: Existing Impervious Coverage
- Figure 3: Soils Map
- Figure 4: Downstream Drainage Map
- Figure 5: Proposed Conditions

## APPENDICES

- Appendix A – Design Drawings
- Appendix B – Design Calculations and Supporting Information
- Appendix C – Construction Stormwater Pollution Prevention Plan (SWPPP)
- Appendix D – Geotechnical Report
- Appendix E – Operations and Maintenance Guidelines



**CHESHIRE RESIDENCE  
7615 E MERCER WAY  
STORMWATER SITE PLAN  
JUNE 27, 2025**

## **PROJECT OVERVIEW**

### **General Project Description**

This storm drainage report is for the construction of a new single-family residence at 7615 E Mercer Way in Mercer Island, Washington. The project site is located in Section 30, Township 24 North, Range 5 East, Willamette Meridian. Refer to Figure 1 – Vicinity Map for site location. The project includes the construction of a new single-family residence.

Based upon the City of Mercer Island Municipal Code (MIMC) Section 15.09.050, the drainage analysis will be assessed using the Department of Ecology (DOE) 2019 Stormwater Manual of Western Washington (SWMWW). Refer to the Minimum Requirements section of this report for the project classification and the minimum requirements that are applicable to the project area.

### **Existing Conditions**

The property (Parcel #3024059036) is currently developed as a single-family residence and has a total area of approximately 77,402 square feet (1.78 acres). Additionally, the site has a driveway, paved areas and a detached accessory dwelling unit (DADU). The DADU is located northeast of the primary residence and will not be impacted by the proposed project. Both the primary residence and DADU have a shared driveway from SE 76<sup>th</sup> Street. According to the City of Mercer Island GIS Portal, the site is zoned R-9.6, Residential. The site is bounded by single-family residences to the north, west, and south. Vehicular access is to the east, via E Mercer Way.

The site topography slopes down from the northwest to the east towards E Mercer Way from a high elevation of approximately 260-feet. The low point on the site is at approximately 120-feet along the east property line. King County critical areas mapping indicates that the entire site is located in a designated Erosion Hazard area. Additionally, according to the City of Mercer Island GIS mapping system, there are Steep Slope and Erosion Hazard areas in the western undeveloped regions of the site. Seismic and Potential Slide Hazard areas cover the entire site.

Per the 2019 DOE Manual, if the existing lot coverage is less than 35% impervious, then the project is to be classified as a new development. The site was found to have impervious coverage of approximately 15.5%, and therefore this project's minimum requirements were determined based on the new development flow chart (Figure I-3.1 of Volume I of the 2019 DOE Manual). Refer to Figure 2 – Existing Impervious Coverage and the Minimum Requirements section of this report.



Per the King County iMap, the project is within the Cedar River – Lake Washington Watershed. Runoff from the site is generally collected in catch basins and conveyed southeast through a piped system to a discharge point into Lake Washington, which is considered a designated receiving waterbody. For more information on the downstream drainage course, see the Offsite Analysis section of this report.

Per the Natural Resources Conservation Service Web Soil Survey, the entire site is underlain with Kitsap silt loam, 15 to 30 percent slopes (KpD). Refer to Figure 3 – Soils Map. A geotechnical report was previously prepared by Geotech Consultants Inc., dated May 2, 2016, for the construction of the DADU located on the site. The report indicates that the site soils near the existing residence consists of medium-stiff to medium dense native soils. Also based upon the mature, straight, evergreen trees and no signs of distress in the existing foundation, Geotech Consultants Inc. concluded that there was no evidence of significant slope movement within the last 50 years. Groundwater seepage was observed in three borings along the north side of the property, ranging in depths from 7.5 to 10 feet. The geotechnical report is included in Appendix D. The City of Mercer Island Infiltration Feasibility Map shows as located in “Basin 38”, in an area where both infiltration is infeasible and infiltration facilities are not permitted. As a result of this, drainage BMPs such as on-site infiltration and dispersion were determined to be infeasible. This will be further discussed in the Permanent Stormwater Control Plan section of this report.

### **Proposed Conditions**

The proposed project will includes replacing the existing single-family residence with a new single-family residence constructed in relatively the same location, as well as, reconstructing the existing driveway due to damage. The existing DADU structure located northeast of the primary residence will not be impacted by the proposed project. The new residence includes outdoor seating, paved walkways, lawn area, and a shed. Refer to the Permanent Stormwater Control Plan section of this report for the additional information about the proposed site conditions.

## **OFFSITE ANALYSIS**

### **Upstream Analysis**

Based on the City of Mercer Island GIS and the King County iMap, as well as the site survey, there is not a significant amount of upstream drainage that will affect the project. There are several properties located uphill from the project area to the northwest and southwest. Stormwater from the northwest properties is collected by an existing piped system on 92<sup>nd</sup> PI SE. The stormwater from properties to the southwest is collected by a piped system located to the south edge of the project area and combine with the runoff from the project site, but will not impede the drainage course. There is sizable forested area to the west of the residence that slopes down toward the home. There will be drainage structures to intercept any potential run-on, but due to dense tree coverage, runoff is expected to be minimal from this upstream area.

### **Downstream Analysis**

The downstream drainage path was determined based on City of Mercer Island GIS storm drainage maps, and the site survey.

Runoff from the existing residence is collected in several catch basins and conveyed south where it enters into a piped system that flows east, parallel to the south edge of the parcel. From here, the downstream drainage path is as follows:

1. Stormwater is conveyed southeast through a 30-inch diameter CMP piped system towards E Mercer Way for approximately 110 feet before reaching E Mercer Way.
2. The stormwater continues southeast through the 30-inch diameter CMP piped system across E Mercer Way for 44 feet before entering a catch basin on the other side of the street.
3. The stormwater exits the catch basin and is conveyed northeast in a 30-inch diameter CMP pipe for approximately 30 feet and enters a catch basin located near the northwest corner of Clarke Beach Park.
4. The stormwater is then conveyed east through the 30-inch diameter CMP pipe system for approximately 430 feet.
5. The stormwater is then conveyed southeast for approximately 106 feet where it outfalls into Lake Washington.

Refer to Figure 4 – Downstream Drainage Map for a visual representation of the downstream drainage path. There are no known issues with the downstream path at this time.

The runoff from existing driveway that will be replaced will be continued to be collected onsite within the existing StormFilter CB at the base of the driveway. This structure is connected to section #2 of the above downstream narrative.

## MINIMUM REQUIREMENTS

Per the previous discussion, the site is considered a new development if there is less than 35% existing impervious coverage. The existing impervious surface coverage for the entire property was determined to be approximately 15.5%, and therefore minimum requirements will be dictated by Figure I-3.1 of the 2019 DOE Manual, which is shown below. There will be more than 5,000 square feet of new plus replaced impervious surface. Therefore, based upon Figure I-3.1 (see below) of the 2019 DOE Stormwater Management Manual for Western Washington, all Minimum Requirements #1 through 9 will apply to **new plus replaced hard surfaces and converted vegetation areas** for the project area.

Figure I-3.1 of the 2019 DOE Stormwater Management Manual for Western Washington

**Figure I-3.1: Flow Chart for Determining Requirements for New Development**

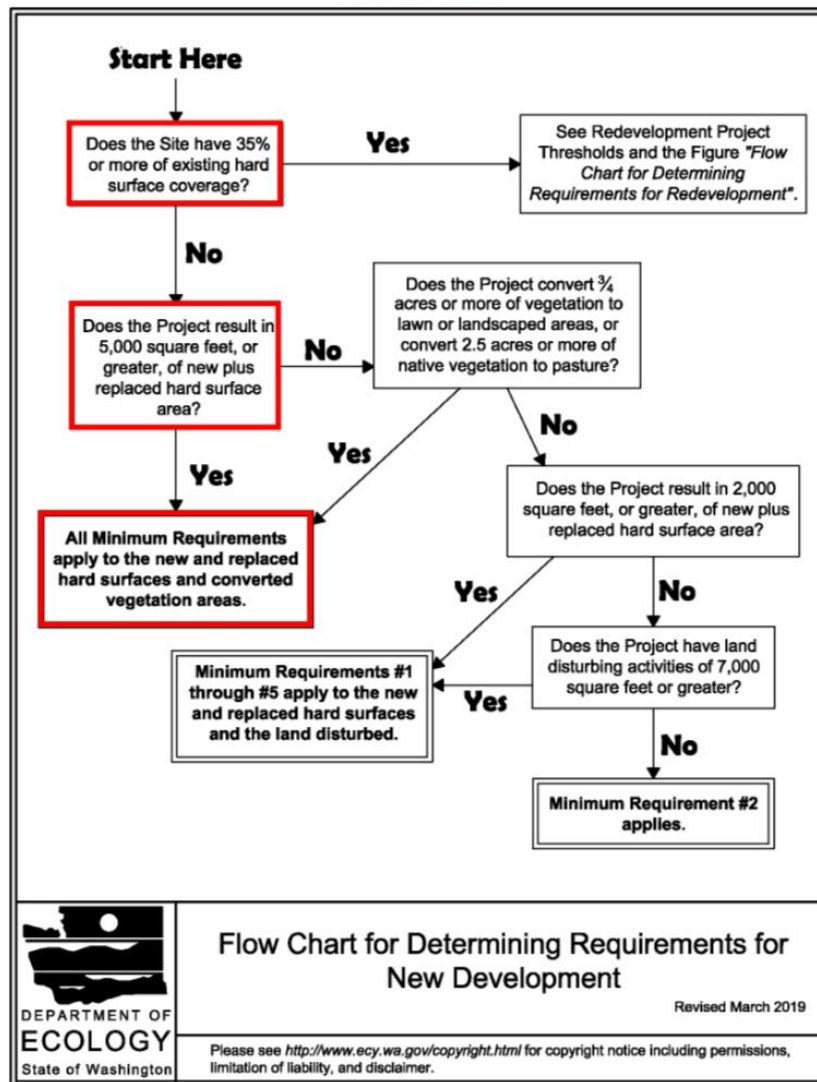



Below is description of each of the minimum requirements for the project and how this project addresses them:

**Minimum Requirement #1 – Preparation of Stormwater Site Plans (MR1):**

This document is the Stormwater Site Plan. It outlines the existing and proposed site and drainage conditions and presents the stormwater analysis.

**Minimum Requirement #2 – Construction Stormwater Pollution Prevention Plan (SWPPP) (MR2):**

The construction SWPPP narrative is included in Appendix C of this report.

**Minimum Requirement #3 – Source Control of Pollution (MR3):**

In the proposed conditions, applicable activities matching those listed within Volume IV of the 2019 DOE Manual that will require the use of source control measures.

- S411 BMPs for Landscaping and Lawn/Vegetation Management
- S417 BMPs for Maintenance of Stormwater Drainage and Treatment Systems

**Minimum Requirement #4 – Preservation of Natural Drainage Systems and Outfalls (MR4):**

The proposed conditions will not alter the general drainage path. In the existing conditions, runoff is collected in catch basins and is conveyed through a piped system to the southeast where it is discharged into Lake Washington approximately 0.14 miles downstream. In the proposed conditions, stormwater will continue to follow this drainage path. Refer to the Offsite Analysis section of this report for a further description of the downstream drainage path and the Permanent Stormwater Control Plan section of this report for the proposed drainage system description.

**Minimum Requirement #5 – On-Site Stormwater Management (MR5):**

The project is subject to on-site stormwater management per section I-3.4.5 of the 2019 DOE Manual. The project is flow control exempt and the project developer did not choose to meet LID standards, therefore the project will adhere to List #3 to evaluate the feasibility of on-site stormwater management BMPs. The only feasible on-site stormwater management is compost amended soils per BMP T5.13 per Volume V of the 2019 DOE Manual, which will be applied to any disturbed pervious area. See the Permanent Stormwater Control Plan for further information.

**Minimum Requirement #6 – Runoff Treatment (MR6):**

The proposed project results in 7,592 square feet (0.174 acres) of pollution generating hard surface (PGHS) area and does not involve any pollution-generating pervious surface (PGPS) area. The project results in more than 5,000 square feet of pollution generating hard surface, therefore water quality treatment is required as defined by Section I-3.4.6 of Volume I of the 2019 DOE Manual. The project will continue to utilize the existing bioretention area for the upper driveway install as part of the Phase 1 improvements and the existing StormFilter system for the replaced driveway, which is a DOE-approved facility that provides enhanced water quality treatment. See the Permanent Stormwater Control Plan for further information.

**Minimum Requirement #7 – Flow Control (MR7):**

The project site stormwater flows through a piped system which has a direct discharge into Lake Washington. According to Section I-3.4.7 of Volume I of the 2019 DOE Manual, flow control is not required for projects that directly or indirectly to a water listed in Appendix I-A: Flow Control



Exempt Receiving Waters. Lake Washington is listed as a Flow Control Exempt Receiving Water. Therefore, flow control is not required for this project.

**Minimum Requirement #8 – Wetland Protection (MR8):**

According to King County iMap and the City of Mercer Island GIS mapping systems there are no wetland areas located near or within the project site.

**Minimum Requirement #9 – Operation and Maintenance (MR9):**

As per Section I-3.4.9 of Volume I of the 2019 DOE Manual, operations and maintenance guidelines have been prepared in accordance with Volume V. The operations and maintenance guidelines are attached in Appendix E of this report. These include required maintenance activities for catch basins from the 2014 DOE Manual Maintenance Standards. In addition, the Maintenance Standards for Bioretention facilities are also provided for reference, as there is an existing bioretention facility located on the property that will receive runoff from a portion of the new driveway.

**PERMANENT STORMWATER CONTROL PLAN**

As noted above, the project is required to address Minimum Requirements #1 – 9 for the **new and replaced hard surfaces** and **converted vegetation areas**. The following table describes the new plus replaced surfaces associated with the project. All roof and standard pavement surfaces are hard surfaces. Refer to Figure 5 – Proposed Conditions for additional information.

**Table 1 – New Plus Replaced Hard Surface**

	<b>Square Feet</b>	<b>Acres</b>
Building Roof	3,917	0.090
Concrete Driveway (PGHS)	7,372	0.169
Paved Walkway/Non-PGHS	1,688	0.039
Gravel	340	0.008
<b>Total New Plus Replaced Hard Surface</b>	<b>13,317</b>	<b>0.306</b>

**Pre-developed Site Hydrology**

Refer to the offsite analysis section of this report for a detailed description of the existing drainage conditions. In general, stormwater is collected in catch basins and conveyed southeast through a 30-inch CMP piped system and outfalls into Lake Washington approximately 0.14 miles downstream of the project site.

**Proposed Site Hydrology**

In the proposed conditions, stormwater from the roof surface will be collected via downspouts on the western side of the residence. A catch basins and pipe system will be installed along the east side of the residence to collect stormwater from the patio, walkways, stairs downspouts and landscaped area and will route the stormwater to the south. At the southwest corner of the residence, this system will collect the footing drain installed around the residence as well as the underdrain and wall drains. The collected stormwater will then be routed east along the south side

of the residence through a piped system to a catch basin at approximately the southeast corner. From this catch basin stormwater will be routed into the 30-inch mainline City system that extends through an easement on the southern property. See downstream system description.

The upper portion of the driveway associated with the new residence will be intercepted in a trench drain prior to the DADU and a portion of the replaced driveway area at the DADU will continue to flow into the existing bioretention area located to the south west of the existing DADU.

The remaining driveway area will flow into the existing StormFilter, which will be maintained and is located at the end of the driveway near property line.

### On-Site Stormwater Management

Since the project triggers Minimum Requirements #1-9, the project must provide on-site stormwater management in accordance with Section I-3.4.5 of Volume I of the 2019 DOE Manual. Figure I-3.3 requires BMPs in List #3 to be evaluated for feasibility, included in the following table. See Table 2 below the figure for a feasibility evaluation of the on-site stormwater management BMPs.

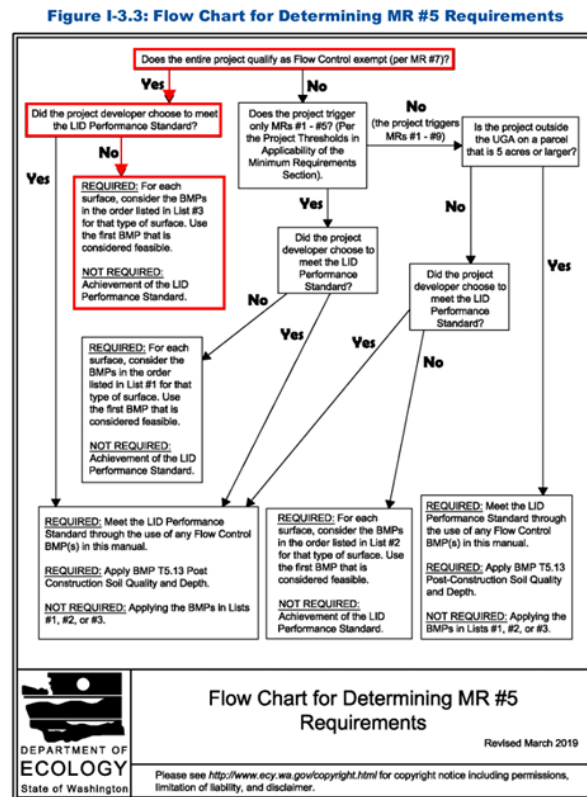



**Table 2 – On-site Stormwater Management BMP Evaluation**

<b>BMP</b>	<b>Feasibility</b>	<b>Explanation</b>
<u>Lawn/Landscaped Areas</u>		
Post-Construction Soil Quality and Depth (T5.13)	Yes	Post-Construction Soil Quality and Depth per BMP T5.13 will be utilized for all disturbed pervious areas that will be restored with lawn or grass.
<u>Roof</u>		
Downspout Full Infiltration (T5.10A) OR Downspout Dispersion Systems (T5.10B) OR Perforated Stub-out Connections (T5.10C)	No	Per the City of Mercer Island Infiltration Feasibility Map this site is located in an area where both infiltration is infeasible and infiltration facilities are not permitted and therefore downspout full infiltration and perforated stub-out connections are infeasible. A downspout dispersion system is also infeasible as there is not an adequate length available for dispersion path and the site topography slopes uphill in the area west of the new residence, where the roof drains will be located.
<u>Other Hard Surfaces</u>		
Concentrated Flow Dispersion (T5.11) OR Sheet Flow Dispersion (T5.12)	No	Concentrated flow dispersion is infeasible as there are no concentrated flows to disperse. The potential flow paths for site surfaces are not long enough to provide adequate dispersion and the site topography slopes uphill from these surfaces. Therefore, sheet flow dispersion is also infeasible.

**Water Quality Treatment**

The project proposes approximately 7,372 SF of new PGHS, and therefore will require water quality treatment. All of these areas were mitigated during phase 1 construction of the onsite DADU and the constructed facilities are proposed to be reused and have been reviewed for the areas tributary.

The existing bioretention area is being used to treat the runoff from part of the parking pad area near the DADU and a portion of the upper driveway and the lower portion of the driveway will be treated by a the existing StormFilter catch basin system. Please refer to Figure 3 for a layout of the areas tributary to the bioretention and StormFilter system.

Previously the bioretention area was sized in accordance with the Enhanced Water Quality Treatment standard, to treat 91 percent of the runoff tributary through the bioretention soil. The bioretention area consists of 18-inches of bioretention soil mix underlain by 12-inches of drain rock over the native subgrade. A 4-inch slotted underdrain will extend the entire length of the bottom of the bioretention area. Based upon the WWHM sizing, the bottom surface area required was 25 SF to treat 3,445 SF of PGHS. Due to grading, now only 3,075 SF is going to the bioretention with the rest bypassing the bioretention area to be treated by the StormFilter. The constructed bioretention has a bottom in excess of 30 square feet and treatment is in excess of the 91 percent required for PGHS runoff.

A StormFilter analysis was previously conducted by Contech Stormwater Solutions, using the project's flow rates calculated in WWHM stormwater modeling. Using WWHM Flood, an analysis of the updated pollution-generating impervious surface of 0.06 ac was conducted, resulting in a 15-minute water quality flow rate of 0.011 cfs. StormFilter ZPG media (zeolite, perlite, granular advanced carbon) is approved for a 27-inch cartridge flow rate of 0.025cfs ( 11.3 gpm)/cartridge. Therefore, one (1) 27-inch cartridge StormFilter structure meets the 2019 DOE Manual's requirements for Enhanced Water Quality Treatment.

The WWHM output for the water quality analysis and calculations by Contech for the StormFilter are included in Appendix B.

A portion of the lower driveway both on and offsite bypass the water quality facility, similar to the design in the phase 1 construction due the required grading of the driveway.

### **Conveyance System Analysis and Design**

An analysis of the onsite conveyance system was performed for the southern outlet pipe connection that will be made to the existing storm system near the southeast corner of the proposed residence. The roof drainage system, non-pollution generating hard surface areas and vegetated uphill area of the site will be tributary to the pipe connection. Refer to the Conveyance Analysis Spreadsheet in Appendix B.

The 2019 DOE manual only requires analysis for the 25-year peak storm for new conveyance systems. However, each pipe analyzed will be compared to the 100-year peak runoff rate as well. These peak flows will be determined using MGS Flood with 15-minute time steps. This was compared to the full-flow capacity of the conveyance pipe, which was determined using Manning's equation.

For the southeast outlet pipe, the full-flow capacity per Manning's Equation for the 6-inch PVC pipe ( $n=0.011$ ) at a minimum 0.5% slope is 0.470 cubic feet per second (cfs). The 25-year and 100-year peak flows from MGS Flood were determined to be 0.147 cfs and 0.187 cfs, respectively. Comparing these peak flows to the full-flow capacity, this pipe will have adequate conveyance capacity.

## **CONSTRUCTION STORMWATER POLLUTION PREVENTION PLAN (SWPPP)**

The SWPPP narrative for this project can be found in Appendix C of this report. The SWPPP is based on Volume II of the 2019 DOE Stormwater Manual requirements. An NPDES permit from the Washington State Department of Ecology will not be required for the project because the disturbance area is less than one acre.

The TESC plan can be found in Appendix A. Due to the excavations associated with this project, a sediment settling tank will be utilized. A minimum volume was calculated using the methodology from the 2019 DOE manual, with the 2-year developed flow rate from MGS Flood. A volume of an equivalent sediment trap was calculated to find the necessary volumes for a sediment tank for this project. A copy of the Sediment Facility Sizing Calculations worksheet used for this exercise is attached in Appendix B. TESC elements in the project include the following:



- Temporary Stabilized Construction Access, per BMP C105
- Catch Basin Inserts (inlet protection), per BMP C220
- Silt Fence, per BMP C233
- Sediment Control Facility, per BMP C241
- Tree Protection Fencing

The TESC elements shown are intended to be the minimum allowable. The City of Mercer Island may require periodic inspection of the TESC elements to confirm they are holding up and continuing to function as intended. During construction, the contractor is responsible for upgrading these facilities as necessary. The implementation of the TESC plan and construction maintenance, replacement, and upgrading of the TESC facilities are the responsibility of the contractor, per the contract documents. The TESC facilities will be constructed prior to and in conjunction with all clearing and grading activity and in a manner in which sediment or sediment laden water does not leave the project site, enter the drainage system, or violate applicable water quality standards.



## **FIGURES**

Figure 1: Vicinity Map

Figure 2: Existing Impervious Coverage

Figure 3: Soil Map

Figure 4: Downstream Drainage Map

Figure 5: Proposed Conditions

File: Figure 1 - Vicinity Map.dwg Path: S:\LPD Engineering PLLC\Projects\Cheshire Residence\Drainage\TIR Exhibits\Plotted by: adis Date: 07-Mar-25 2:20:01 pm

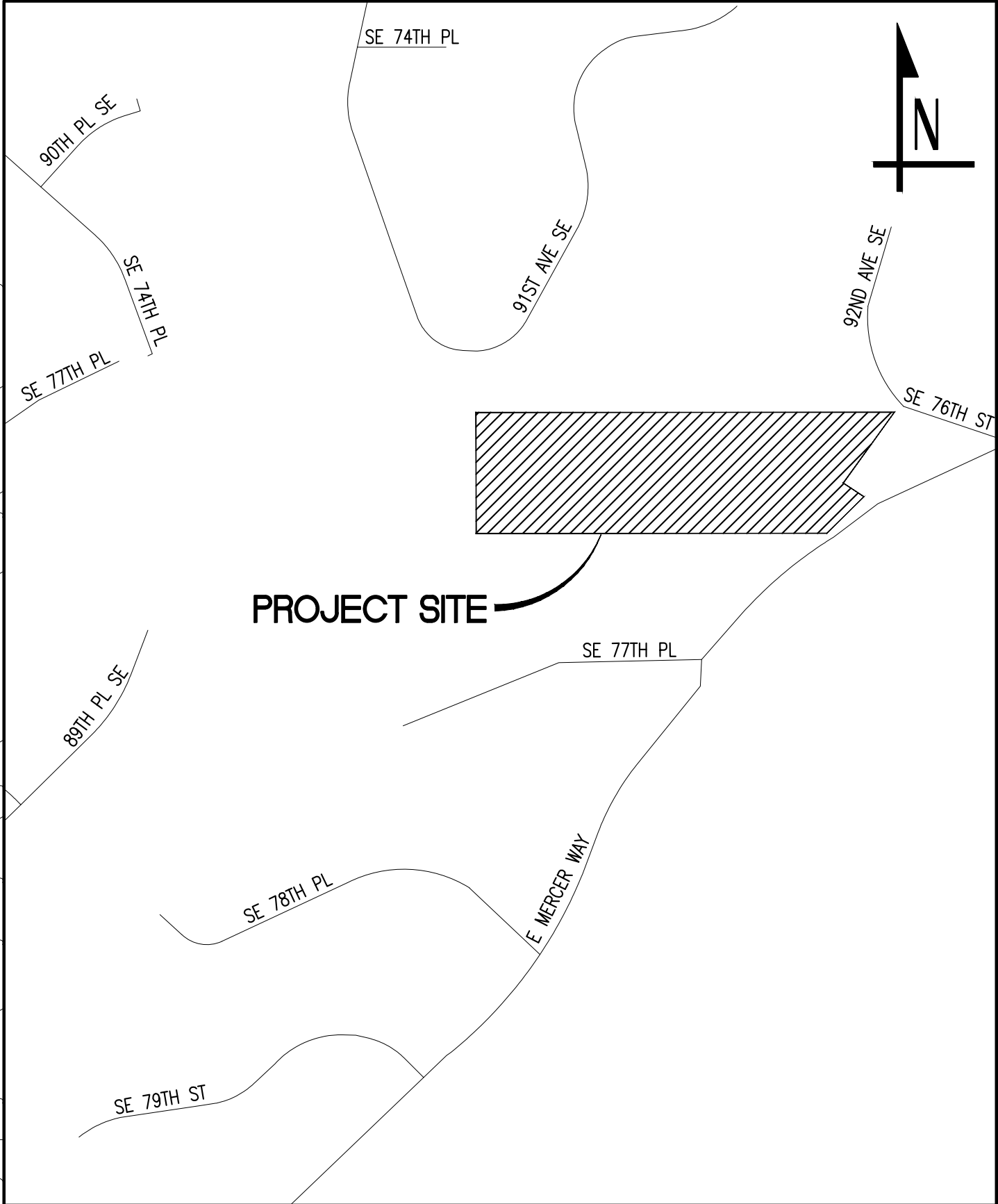

# CHESHIRE RESIDENCE



1932 First Ave  
Suite 500  
Seattle, WA 98101  
p. 206.725.1211  
f. 206.973.5344

engineering pllc [www.lpdengineering.com](http://www.lpdengineering.com)

DESCRIPTION

## VICINITY MAP

MARCH 7, 2025

FIGURE

# 1

File: Figure 2 - Existing Impervious Coverage.dwg Date: 07-Mar-25 2:20:38pm

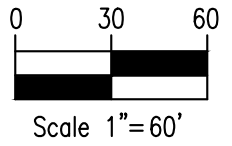
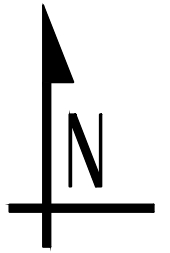
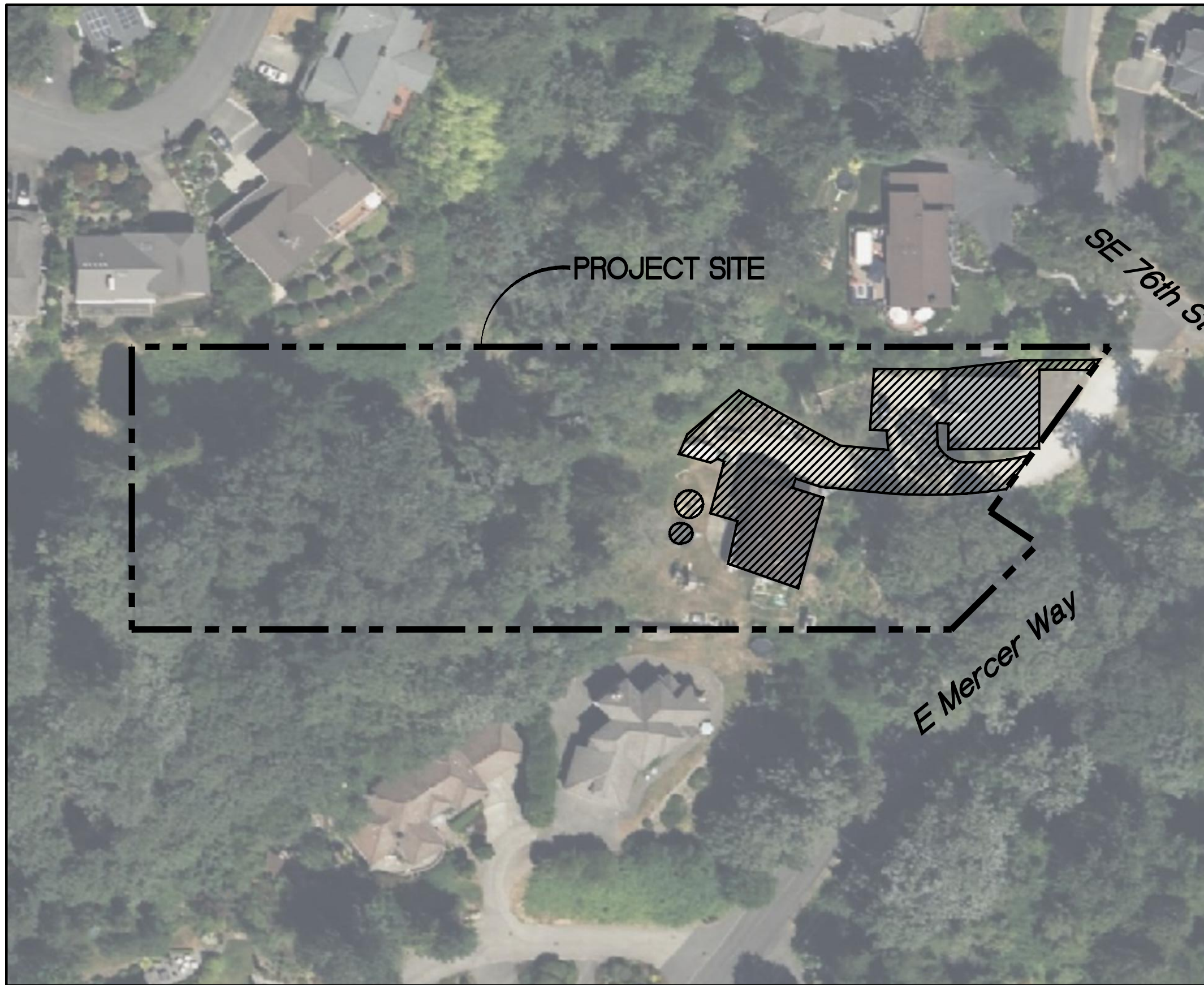

EXISTING IMPERVIOUS AREA	
 Existing Impervious	0.276 AC
Total Site Area	1.777 AC
Percentage of Site Impervious	15.5%

### CHESHIRE RESIDENCE

© 2023 LPD Engineering PLLC

**LPD**  
engineering pllc  
www.lpdengineering.com

1932 First Ave  
Suite 500  
Seattle, WA 98101  
p. 206.725.1211  
f. 206.973.5344

DESCRIPTION	MARCH 7, 2025	FIGURE
<b>EXISTING IMPERVIOUS COVERAGE</b>		<b>2</b>



KING COUNTY AREA, WASHINGTON (WA633)

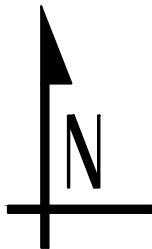

MAP UNIT SYMBOL	MAP UNIT NAME
AgB	Alderwood Gravelly Sandy Loam, 0% to 8% slopes
EwC	Everett-Alderwood gravelly sandy loams, 6% to 15% slopes
KpD	Kitsap Silt Loam, 15% to 30% slopes

CHESHIRE RESIDENCE

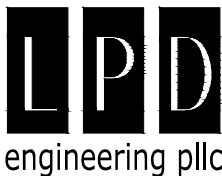

1932 First Ave  
Suite 500  
Seattle, WA 98101  
p. 206.725.1211  
f. 206.973.5344

www.lpdengineering.com

DESCRIPTION

SOILS MAP

MARCH 7, 2025

FIGURE

3

s:\lpd\_engineering\_pllc\projects\cheshire\_residence\drainage\figure 4 - downstream drainage map.dwg adis 3/7/2025 2:30 PM

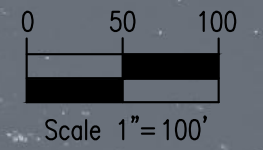
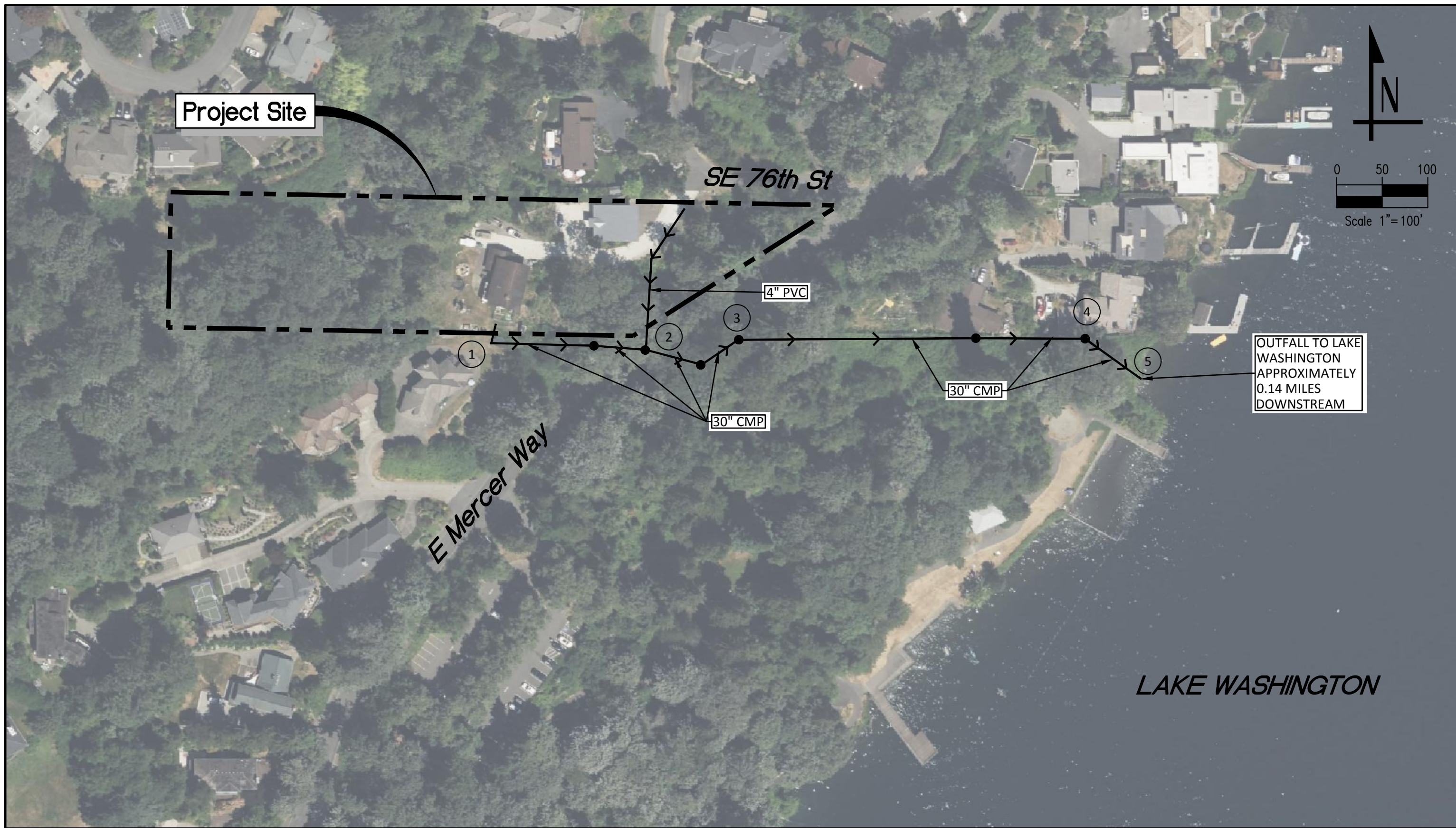

OUTFALL TO LAKE WASHINGTON  
APPROXIMATELY  
0.14 MILES  
DOWNSTREAM

*LAKE WASHINGTON*

**CHESHIRE RESIDENCE**

© 2023 LPD Engineering PLLC

**LPD**  
engineering pllc  
1932 1st Ave,  
Suite 500,  
Seattle, WA 98101  
p. 206.725.1211  
f. 206.973.5344  
www.lpdengineering.com



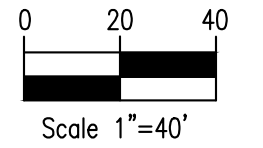
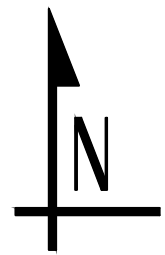
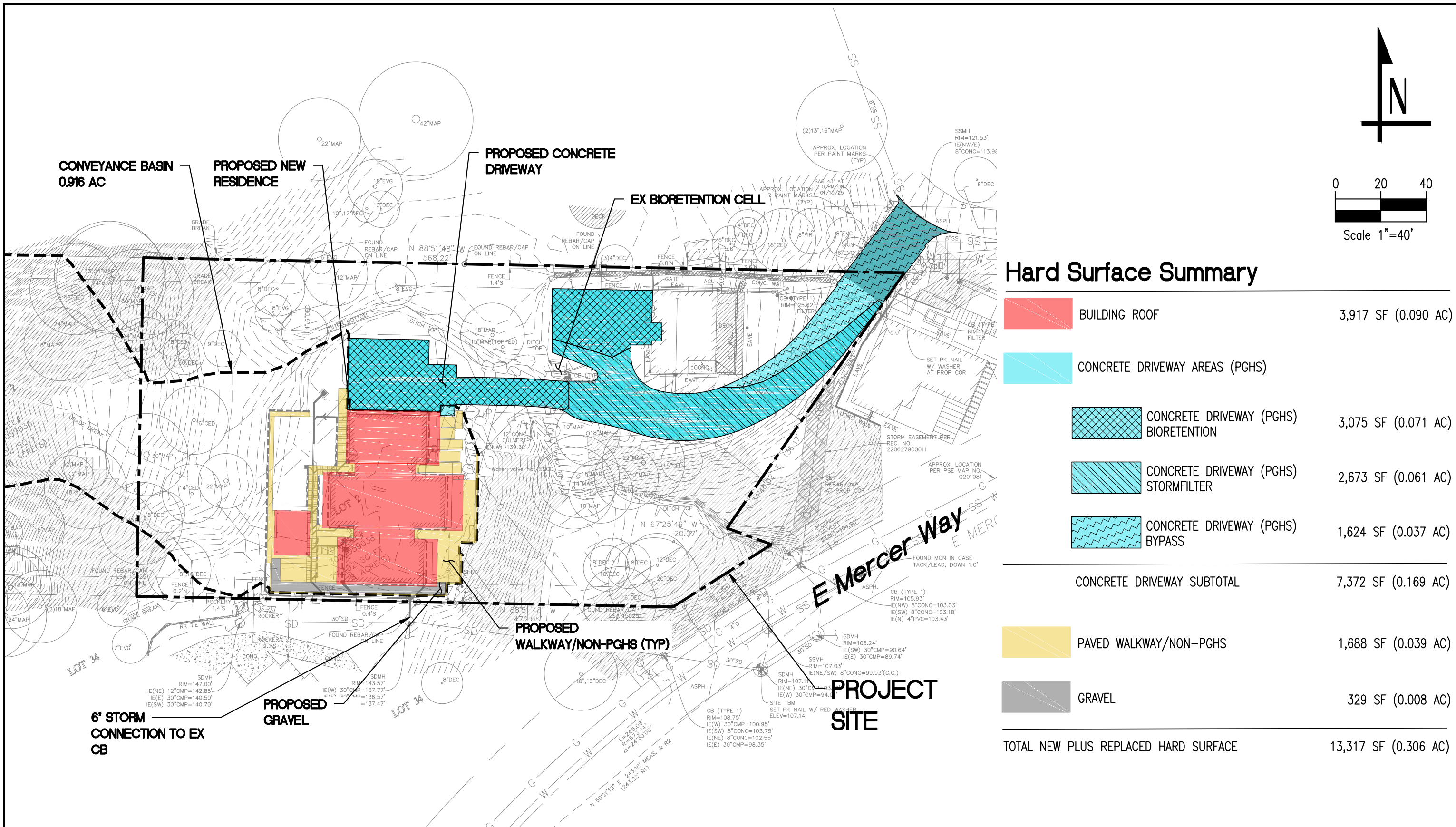

DESCRIPTION	MARCH 7, 2025
<b>DOWNSTREAM DRAINAGE MAP</b>	

FIGURE  
**4**

s:\lpd\engineering\pllc\projects\cheshire residence\drainage\ir exhibits\figure 5 - proposed conditions.dwg simonw 6/27/2025 4:15 PM

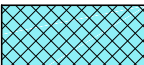
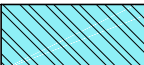
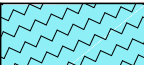

### Hard Surface Summary

	BUILDING ROOF	3,917 SF (0.090 AC)
	CONCRETE DRIVEWAY AREAS (PGHS)	
	CONCRETE DRIVEWAY (PGHS) BIORETENTION	3,075 SF (0.071 AC)
	CONCRETE DRIVEWAY (PGHS) STORMFILTER	2,673 SF (0.061 AC)
	CONCRETE DRIVEWAY (PGHS) BYPASS	1,624 SF (0.037 AC)
CONCRETE DRIVEWAY SUBTOTAL		7,372 SF (0.169 AC)
	PAVED WALKWAY/NON-PGHS	1,688 SF (0.039 AC)
	GRAVEL	329 SF (0.008 AC)
TOTAL NEW PLUS REPLACED HARD SURFACE		13,317 SF (0.306 AC)



## **APPENDIX A**

### Design Drawings

Section 30, Township 24N, range 5E W.M.

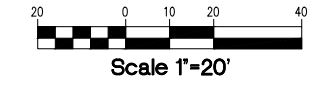
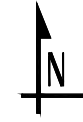

LEGEND

- PROPERTY LINE
- EX CONTOUR (INDEX)
- EX CONTOUR
- EX BUILDING
- PROPOSED BUILDING OUTLINE
- BUILDING/STRUCTURE REMOVAL
- SAWCUT LINE
- CONCRETE REMOVAL
- SAWCUT LINE
- ASPHALT REMOVAL
- STABILIZED CONSTRUCTION ENTRANCE
- FILTER FENCE
- EX TREE TO REMAIN
- TREE PROTECTION
- INLET PROTECTION
- LIMITS OF WORK
- TEMP. FORCE MAIN
- TURBIDITY MONITORING LOCATION

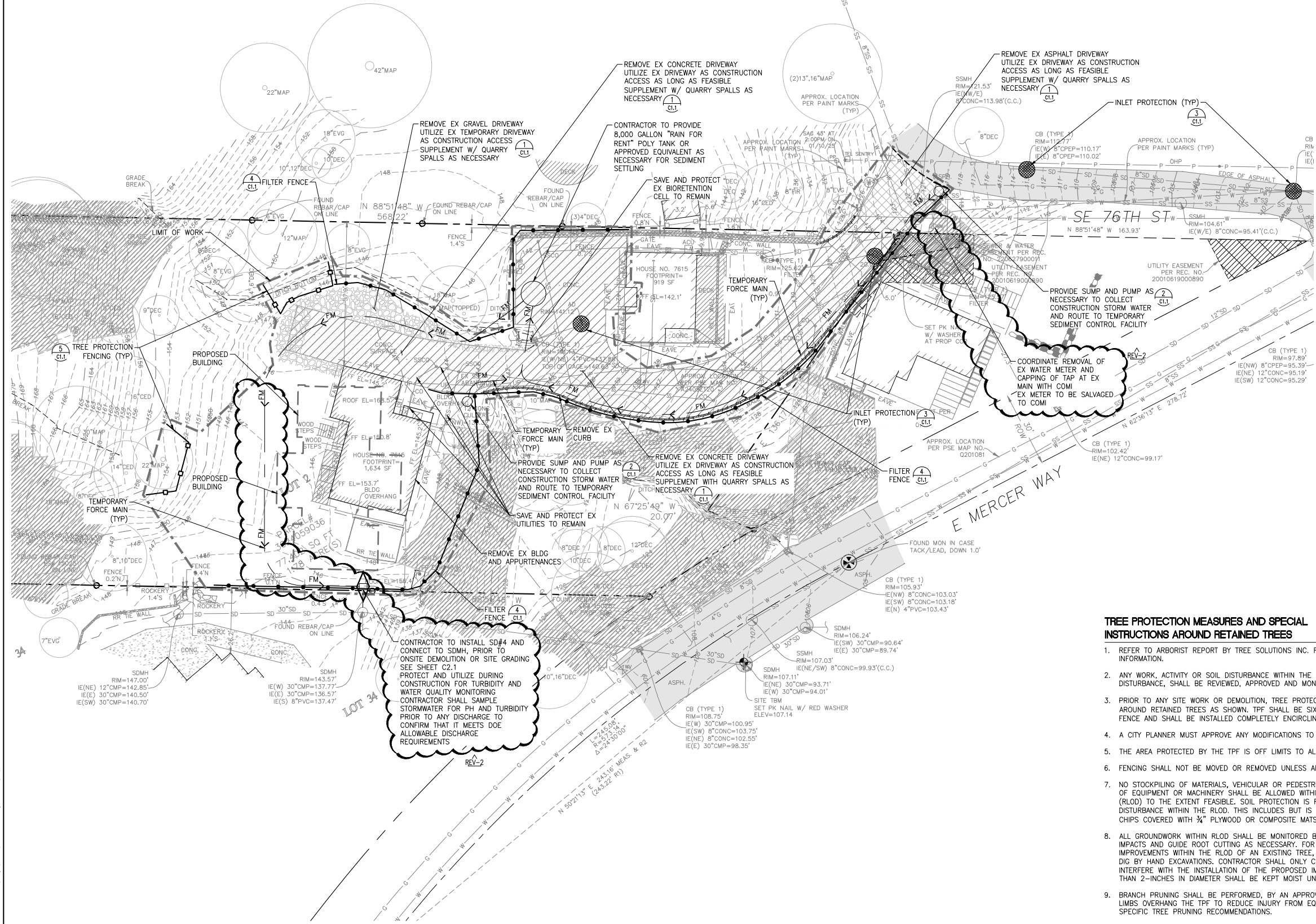

CONTRACTOR TO INSTALL SD#4 AND CONNECT TO SDMH, PRIOR TO ON-SITE DEMOLITION OR SITE GRADING SEE SHEET C2.1  
 PROTECT AND UTILIZE DURING CONSTRUCTION FOR TURBIDITY AND WATER QUALITY MONITORING  
 CONTRACTOR SHALL SAMPLE STORMWATER FOR PH AND TURBIDITY PRIOR TO ANY DISCHARGE TO CONFIRM THAT IT MEETS DOE ALLOWABLE DISCHARGE REQUIREMENTS

**TREE PROTECTION MEASURES AND SPECIAL INSTRUCTIONS AROUND RETAINED TREES**

1. REFER TO ARBORIST REPORT BY TREE SOLUTIONS INC. FOR TREE PROTECTION AND MANAGEMENT INFORMATION.
2. ANY WORK, ACTIVITY OR SOIL DISTURBANCE WITHIN THE PROTECTION FENCING, OR LIMIT OF DISTURBANCE, SHALL BE REVIEWED, APPROVED AND MONITORED BY THE PROJECT ARBORIST.
3. PRIOR TO ANY SITE WORK OR DEMOLITION, TREE PROTECTION FENCING (TPF) SHALL BE ERECTED AROUND RETAINED TREES AS SHOWN. TPF SHALL BE SIX (6) FOOT TEMPORARY CHAIN-LINK FENCE AND SHALL BE INSTALLED COMPLETELY ENCIROILING THE RETAINED TREES.
4. A CITY PLANNER MUST APPROVE ANY MODIFICATIONS TO THE FENCING MATERIAL AND LOCATION.
5. THE AREA PROTECTED BY THE TPF IS OFF LIMITS TO ALL CONSTRUCTION RELATED ACTIVITY.
6. FENCING SHALL NOT BE MOVED OR REMOVED UNLESS APPROVED BY A CITY PLANNER.
7. NO STOCKPILING OF MATERIALS, VEHICULAR OR PEDESTRIAN TRAFFIC, MATERIAL STORAGE OR USE OF EQUIPMENT OR MACHINERY SHALL BE ALLOWED WITHIN RECOMMENDED LIMIT OF DISTURBANCE (RLOD) TO THE EXTENT FEASIBLE. SOIL PROTECTION IS REQUIRED FOR CONSTRUCTION DISTURBANCE WITHIN THE RLOD. THIS INCLUDES BUT IS NOT LIMITED TO 6-INCHES OF WOOD CHIPS COVERED WITH 3/4" PLYWOOD OR COMPOSITE MATS.
8. ALL GROUNDWORK WITHIN RLOD SHALL BE MONITORED BY PROJECT ARBORIST TO ASSESS ROOT IMPACTS AND GUIDE ROOT CUTTING AS NECESSARY. FOR ANY UTILITY TRENCHES OR OTHER IMPROVEMENTS WITHIN THE RLOD OF AN EXISTING TREE, THE CONTRACTOR SHALL AIR SPADE OR DIG BY HAND EXCAVATIONS. CONTRACTOR SHALL ONLY CUT REG'D ROOTS LESS THAN 2" THAT INTERFERE WITH THE INSTALLATION OF THE PROPOSED IMPROVEMENTS. EXPOSED ROOTS GREATER THAN 2-INCHES IN DIAMETER SHALL BE KEPT MOIST UNTIL BACKFILLED.
9. BRANCH PRUNING SHALL BE PERFORMED, BY AN APPROVED ISA CERTIFIED ARBORIST, WHERE LIMBS OVERHANG THE TPF TO REDUCE INJURY FROM EQUIPMENT. SEE ARBORIST REPORT FOR SPECIFIC TREE PRUNING RECOMMENDATIONS.



No.	Revisions	Date
REV2	BUILDING PERMIT CITY CORRECTIONS	2025-06-27



Project Name  
**CHESHIRE RESIDENCE**  
**7615 E. MERCER WAY**  
 City of Mercer Island, Washington

Project No.	
Issue Date	MARCH 07, 2025
Scale	As Noted
Designed	ACW
Checked	LJP
Drawn	SBR
Approved	LJP

Description  
**TESC AND DEMOLITION PLAN**

Sheet  
**C1.0**

Call 3 Working Days Before You Dig!  
 1-800-424-6555

© LPD engineering pllc. All rights reserved. Cheshire residence (Design) (Sheet) (Title) - cheshire.dwg, 6/27/2025, 4:10 PM

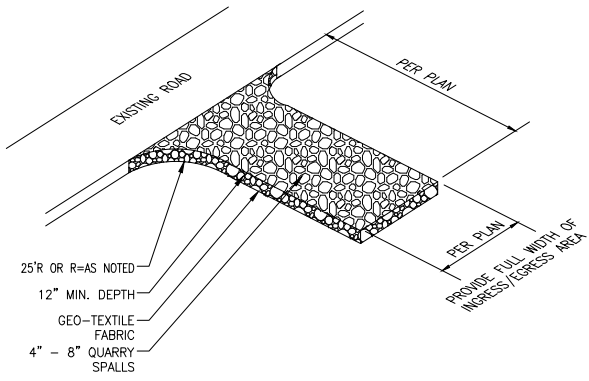

NTS  
CONSTRUCTION ENTRANCE 1

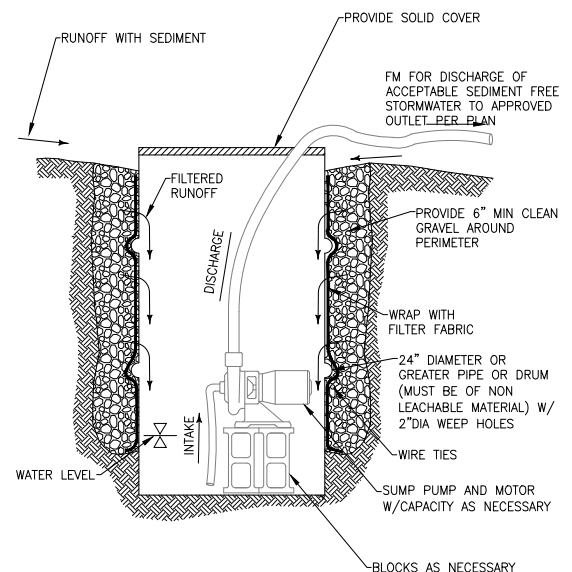

NTS  
MOVEABLE SUMP & PUMP 2

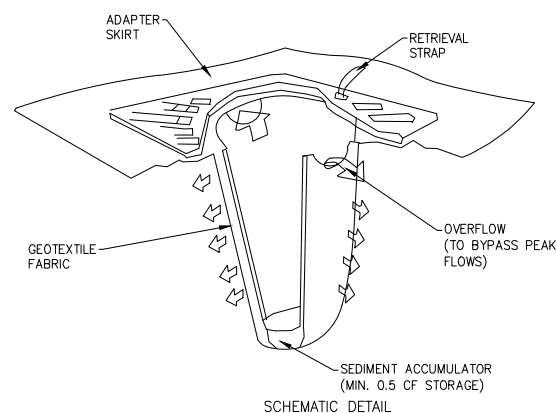

NTS  
INLET PROTECTION 3

PROVIDE "STREAMGUARD SEDIMENT CATCH BASIN INSERT" OR APPROVED EQUAL MANUFACTURER INFORMATION:  
BOWHEAD ENVIRONMENTAL & SAFETY  
P.O. BOX 375  
PRESTON, WA 98050  
(800) 909-3677  
WWW.SHOPBOWHEAD.COM

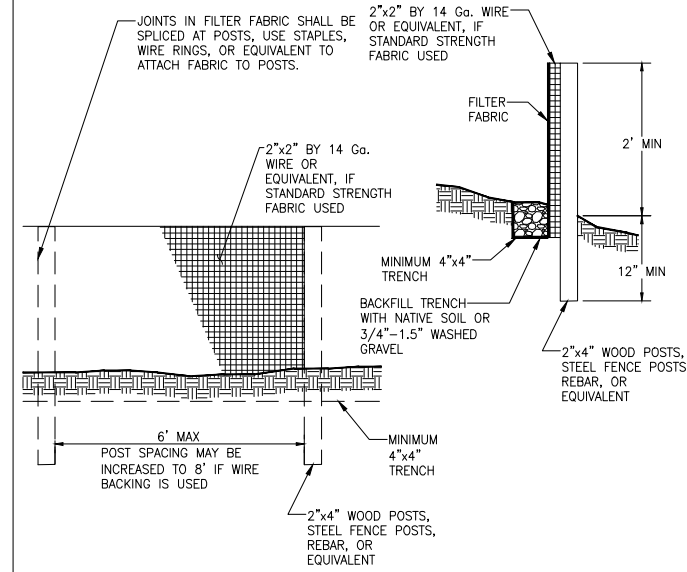

NTS  
FILTER FENCE 4

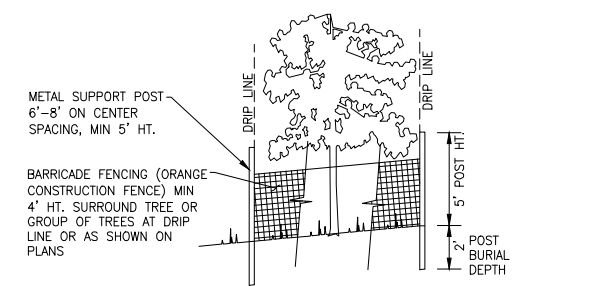

- NOTES:
- A 4 FOOT HIGH TEMPORARY FENCE MUST BE PLACED AT THE DRIP LINE OF TREES PRIOR TO THE COMMENCEMENT OF CLEARING OR EARTHWORK. NOTIFY THE CLEARING AND GRADING INSPECTOR TO GET BOTH THE INSPECTION AND WRITTEN APPROVAL OF FLAGGED TREES AND TEMPORARY PROTECTION FENCING AROUND TREES TO BE SAVED PER THE APPROVED CLEARING AND GRADING PLAN.
  - NO STOCKPILING OF MATERIAL AND NO VEHICULAR TRAFFIC ARE ALLOWED WITHIN THE LIMITS OF THE DRIPLINE. THE TEMPORARY FENCING, UNLESS APPROVED BY THE ARBORIST, FILLING, EXCAVATION, AND CLEARING MUST BE ACCOMPLISHED BY HAND METHODS ONLY UNLESS APPROVED BY ARBORIST.
  - ROOTS OF TREES TO BE SAVED WHICH ARE DAMAGED DURING CONSTRUCTION MUST BE TREATED IN THE FOLLOWING WAY: FOR DAMAGED ROOTS OVER 1" IN DIAMETER, MAKE A CLEAN, STRAIGHT CUT TO REMOVE THE DAMAGED PORTION OF THE ROOT ALL EXPOSED ROOTS WILL BE TEMPORARILY COVERED WITH DAMP BURLAP OR WOOD SHAVINGS TO PREVENT DRYING AND COVERED WITH EARTH AS SOON AS POSSIBLE.

NTS  
TREE PROTECTION 5

GENERAL NOTES

- ANY CHANGES TO THE APPROVED PLANS REQUIRES CITY APPROVAL THROUGH A REVISION.
- APPLICANT IS RESPONSIBLE FOR ANY DAMAGES TO UNDERGROUND UTILITIES CAUSED FROM THIS CONSTRUCTION.
- CATCH BASIN FILTERS SHOULD BE PROVIDED FOR ALL STORM DRAIN CATCH BASIN/INLETS DOWNSLOPE AND WITHIN 500 FEET OF THE CONSTRUCTION AREA. CATCH BASIN FILTERS SHOULD BE DESIGNED BY THE MANUFACTURER FOR USE AT CONSTRUCTION SITES AND APPROVED BY THE CITY INSPECTOR. CATCH BASIN FILTERS SHOULD BE INSPECTED FREQUENTLY, ESPECIALLY AFTER STORM EVENTS. IF THE FILTER BECOMES CLOGGED, IT SHOULD BE CLEANED OR REPLACED.
- CONTRACTORS SHALL VERIFY LOCATIONS AND DEPTHS OF UTILITIES.
- AT LEAST 48 HOURS PRIOR TO CONSTRUCTION, CALL "ONE CALL" AT 1.800.425.5555.
- DO NOT BACKFILL WITH NATIVE MATERIAL ON PUBLIC RIGHT-OF-WAY. ALL MATERIAL MUST BE IMPORTED.
- EROSION CONTROL: ALL "LAND DISTURBING ACTIVITY" IS SUBJECT TO PROVISIONS OF MERCER ISLAND ORDINANCE 95C-118 "STORM WATER MANAGEMENT." SPECIFIC ITEMS TO BE FOLLOWED AT YOUR SITE.
- PROTECT ADJACENT PROPERTIES FROM ANY INCREASED RUNOFF OR SEDIMENTATION DUE TO THE CONSTRUCTION PROJECT THROUGH THE USE OF APPROPRIATE "BEST MANAGEMENT PRACTICES" (BMP) EXAMPLES INCLUDE, BUT ARE NOT LIMITED TO, SEDIMENT TRAPS, SEDIMENT PONDS, FILTER FABRIC FENCES, VEGETATIVE BUFFER STRIPS OR BIO ENGINEERED SWALES.
- CONSTRUCTION ACCESS TO SITE SHOULD BE LIMITED TO ONE ROUTE. STABILIZE ENTRANCE WITH QUARRY SPALLS TO PREVENT SEDIMENT FROM LEAVING THE SITE OR ENTERING THE STORM DRAINS.
- PREVENT SEDIMENT, CONSTRUCTION DEBRIS, PAINTS, SOLVENTS, ETC., OR OTHER TYPES OF POLLUTION FROM ENTERING PUBLIC STORM DRAINS. KEEP ALL POLLUTION ON YOUR SITE.
- ALL EXPOSED SOILS SHALL REMAIN DENUDE FOR NO LONGER THAN SEVEN (7) DAYS AND SHALL BE STABILIZED WITH MULCH, HAY, OR THE APPROPRIATE GROUND COVER. ALL EXPOSED SOILS SHALL BE COVERED IMMEDIATELY DURING ANY RAIN EVENT.
- INSTALLATION OF CONCRETE DRIVEWAYS, TREES, SHRUBS, IRRIGATION, BOULDERS, BERMS, WALLS, GATES, AND OTHER IMPROVEMENTS ARE NOT ALLOWED IN THE PUBLIC RIGHT-OF-WAY WITHOUT PRIOR APPROVAL, AND AN ENCROACHMENT AGREEMENT AND RIGHT OF WAY PERMIT FROM THE SENIOR DEVELOPMENT ENGINEER.
- OWNER SHALL CONTROL DISCHARGE OF SURFACE DRAINAGE RUNOFF FROM EXISTING AND NEW IMPERVIOUS AREAS IN A RESPONSIBLE MANNER. CONSTRUCTION OF NEW GUTTERS AND DOWNSPOUTS, DRY WELLS, LEVEL SPREADERS OR DOWNSSTREAM CONVEYANCE PIPE MAY BE NECESSARY TO MINIMIZE DRAINAGE IMPACT TO YOUR NEIGHBORS. CONSTRUCTION OF MINIMUM DRAINAGE IMPROVEMENTS SHOWN OR CALLED OUT ON THIS PLAN DOES NOT IMPLY RELIEF FROM CIVIL LIABILITY FOR YOUR DOWNSTEAM DRAINAGE.
- POT HOLING THE PUBLIC UTILITIES IS REQUIRED PRIOR TO ANY GRADING ACTIVITIES LESS THAN 6" OVER THE PUBLIC MAINS (WATER, SEWER AND STORM SYSTEMS). IF THERE IS A CONFLICT, THE APPLICANT IS REQUIRED TO SUBMIT A REVISION FOR APPROVAL PRIOR TO ANY GRADING ACTIVITIES OVER THE PUBLIC MAINS.
- REMEMBER: EROSION CONTROL IS YOUR FIRST INSPECTION.
- ROOF DRAINS MUST BE CONNECTED TO THE STORM DRAIN SYSTEM AND INSPECTED BY THE PUBLIC WORKS DEPARTMENT PRIOR TO ANY BACKFILLING OF PIPE.
- SILT FENCE: CLEAN AND PROVIDE REGULAR MAINTENANCE OF THE SILT FENCE. THE FENCE IS TO REMAIN VERTICAL AND IS TO FUNCTION PROPERLY THROUGHOUT THE TERM OF THE PROJECT.
- WORK IN PUBLIC RIGHT OF WAY REQUIRES A RIGHT-OF-WAY USE PERMIT.
- REFER TO WATER SERVICE PERMIT FOR ACTUAL LOCATION OF NEW WATER METER AND SERVICE LINE DETERMINED BY MERCER ISLAND WATER DEPARTMENT.
- THE TV INSPECTION OF THE EXISTING SIDE SEWER TO THE CITY SEWER MAIN IS REQUIRED. IF THE RESULT OF THE TV INSPECTION IS NOT IN SATISFACTORY CONDITION, AS DETERMINED BY THE CITY OF MERCER ISLAND INSPECTOR, THE REPLACEMENT OF THE EXISTING SIDE SEWER IS REQUIRED. ALTERNATELY, A PRESSURE TEST OF THE SIDE SEWER, FROM SEWER MAIN TO POINT OF CONNECTION, MAY BE SUBSTITUTED FOR THE VIDEO INSPECTION.
- NEWLY INSTALLED SIDE SEWER REQUIRES A 4 P.S.I. AIR TEST OR PROVIDE 10' OF HYDROSTATIC HEAD TEST.
- THE LIMITS AND EXTENTS OF THE PAVEMENT IN THE PUBLIC RIGHT OF WAY SHALL BE DETERMINED BY THE CITY ENGINEER PRIOR TO FINALIZING THE PROJECT.
- TREE PROTECTION INSPECTION REQUIRED BEFORE ANY WORK BEGINS, CALL 206-275-7713.

NTS  
NOT USED 6

NTS  
GENERAL NOTES 11

EROSION CONTROL NOTES

- THE IMPLEMENTATION OF THESE EROSION SEDIMENTATION CONTROL (ESC) PLANS AND THE CONSTRUCTION, MAINTENANCE, REPLACEMENT, AND UPGRADING OF THESE ESC FACILITIES IS THE RESPONSIBILITY OF THE CONTRACTOR UNTIL ALL CONSTRUCTION IS APPROVED.
- THE ESC FACILITIES SHOWN ON THIS PLAN MUST BE CONSTRUCTED IN CONJUNCTION WITH ALL CLEARING AND GRADING ACTIVITIES IN SUCH A MANNER AS TO INSURE THAT SEDIMENT-LADEN WATER DOES NOT ENTER THE DRAINAGE SYSTEM OR VIOLATE APPLICABLE WATER STANDARDS, AND MUST BE COMPLETED PRIOR TO ALL OTHER CONSTRUCTION.
- THE ESC FACILITIES SHOWN ON THIS PLAN ARE THE MINIMUM REQUIREMENTS FOR ANTICIPATED SITE CONDITIONS. DURING THE CONSTRUCTION PERIOD, THESE ESC FACILITIES SHALL BE UPGRADED (E.G. ADDITIONAL SUMPS, RELOCATION OF DITCHES AND SILT FENCES), AS NEEDED FOR UNEXPECTED STORM EVENTS. ADDITIONALLY MORE ESC FACILITIES MAY BE REQUIRED TO ENSURE COMPLETE SILTATION CONTROL. THEREFORE, DURING THE COURSE OF CONSTRUCTION IT SHALL BE THE OBLIGATION AND RESPONSIBILITY OF THE CONTRACTOR TO ADDRESS ANY NEW CONDITIONS THAT MAY BE CREATED BY THEIR ACTIVITIES AND TO PROVIDE ADDITIONAL FACILITIES OVER AND ABOVE THE MINIMUM REQUIREMENTS AS MAY BE NEEDED.
- THE ESC FACILITIES SHALL BE INSPECTED DAILY DURING NON-RAINFALL PERIODS, EVERY HOUR (DAYLIGHT) DURING A RAINFALL EVENT AND AT THE END OF EVERY RAINFALL BY THE PERMIT HOLDER/CONTRACTOR AND MAINTAINED AS NECESSARY TO ENSURE THEIR CONTINUED FUNCTIONING. IN ADDITION, TEMP. SILTATION PONDS AND ALL TEMP. SILTATION CONTROLS SHALL BE MAINTAINED IN A SATISFACTORY CONDITION UNTIL SUCH TIME THAT CLEARING AND OR CONSTRUCTION IS COMPLETED, PERMANENT DRAINAGE FACILITIES ARE OPERATIONAL, AND THE POTENTIAL FOR EROSION HAS PASSED.
- ANY AREA STRIPPED OF VEGETATION, INCLUDING ROADWAY EMBANKMENTS WHERE NO FURTHER WORK IS ANTICIPATED FOR A PERIOD OF SEVEN (7) DAYS, SHALL BE IMMEDIATELY STABILIZED WITH THE APPROVED ESC METHODS (E.G. SEEDING, MULCHING, NETTING, EROSION, BLANKETS, ETC.).
- ANY AREAS NEEDING ESC MEASURES, NOT REQUIRING IMMEDIATE ATTENTION, SHALL BE ADDRESSED WITHIN SEVEN (7) DAYS.
- THE ESC FACILITIES ON INACTIVE SITES SHALL BE INSPECTED AND MAINTAINED A MINIMUM OF ONCE A MONTH OR WITHIN THE 48 HOURS FOLLOWING A STORM EVENT.
- AT NO TIME SHALL MORE THAN ONE FOOT OF SEDIMENT BE ALLOWED TO ACCUMULATE WITHIN A CATCH BASIN. ALL CATCH BASINS AND CONVEYANCE LINES SHALL BE CLEANED PRIOR TO PAVING. THE CLEANING OPERATION SHALL NOT FLUSH SEDIMENT LADEN WATER INTO DOWNSTEAM SYSTEM.
- WHERE SEEDING FOR TEMPORARY EROSION CONTROL IS REQUIRED, FAST GERMINATING GRASSES SHALL BE APPLIED AT AN APPROPRIATE RATE (E.G. ANNUAL OR PERENNIAL RYE APPLIED AT APPROXIMATELY 80 POUNDS PER ACRE).
- WHERE STRAW MULCH FOR TEMPORARY EROSION CONTROL IS REQUIRED, IT SHALL BE APPLIED AT A MINIMUM THICKNESS OF THREE INCHES.
- ALL WORK AND MATERIALS SHALL BE IN ACCORDANCE WITH THE CITY OF MERCER ISLAND STANDARDS AND SPECIFICATIONS.
- EROSION/SEDIMENTATION CONTROL FACILITIES SHALL BE CONSTRUCTED IN ACCORDANCE WITH THE DETAILS IN DEPARTMENT OF ECOLOGY STORMWATER MANAGEMENT MANUAL, UNLESS OTHERWISE APPROVED BY THE CITY ENGINEER.
- A COPY OF THE APPROVED EROSION CONTROL PLANS MUST BE ON THE JOB SITE WHENEVER CONSTRUCTION IS IN PROGRESS.
- TEMPORARY EROSION/SEDIMENTATION CONTROLS SHALL BE INSTALLED & OPERATING PRIOR TO ANY GRADING OR LAND CLEARING.
- WHEREVER POSSIBLE, MAINTAIN NATURAL VEGETATION FOR SILT CONTROL.
- ALL CUT AND FILL SLOPES 5:1 (5 FEET HORIZONTAL TO 1 FOOT VERTICAL) OR STEEPER THAT WILL BE LEFT EXPOSED FOR MORE THAN 7 DAYS SHALL BE PROTECTED BY JUTE MATTING, PLASTIC SHEETING, MULCH, OR OTHER APPROVED STABILIZATION METHOD AND PROVIDED WITH ADEQUATE RUNOFF CONVEYANCE TO INTERCEPT RUNOFF AND CONVEY IT TO AN APPROVED STORM DRAIN.
- OFF-SITE STREETS MUST BE KEPT CLEAN AT ALL TIMES. IF DIRT IS DEPOSITED ON THE PUBLIC STREET, THE STREET SHALL BE CLEANED. ALL VEHICLES SHALL LEAVE THE SITE BY WAY OF THE CONSTRUCTION VEHICLE ENTRANCE AND SHALL BE CLEANED OF MUD PRIOR TO EXITING ONTO THE STREET. SILT SHALL BE CLEANED FROM ALL CATCH BASINS WHEN THE BOTTOM HALF BECOMES FILLED WITH SILT.
- ANY CATCH BASIN COLLECTING WATER FROM THE SITE, WHETHER THEY ARE ON OR OFF OF THE SITE, SHALL HAVE THEIR GRATES COVERED WITH FILTER FABRIC DURING CONSTRUCTION.
- IF ANY PORTION OF THE EROSION/SEDIMENTATION CONTROL ELEMENTS ARE DAMAGED OR NOT FUNCTIONING, OR IF THE CLEARING LIMIT BOUNDARY BECOMES NON-DEFINED, IT SHALL BE REPAIRED IMMEDIATELY.

NTS  
EROSION CONTROL NOTES 12



No.	Revisions	Date
REV2	BUILDING PERMIT CITY CORRECTIONS	2025-06-27

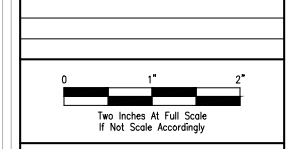

Project Name

**CHESHIRE RESIDENCE**  
**7615 E. MERCER WAY**  
 City of Mercer Island, Washington

Project No.	
Issue Date	MARCH 07, 2025
Scale	As Noted
Designed	ACW
Checked	LJP
Drawn	SBR
Approved	LJP

Description  
**TESC AND DEMOLITION DETAILS AND NOTES**

Sheet  
**C1.1**

© 2025 LPD Engineering, LLC. All rights reserved. This drawing is the property of LPD Engineering, LLC. No part of this drawing may be reproduced without the written permission of LPD Engineering, LLC.

Section 30, Township 24N, range 5E W.M.

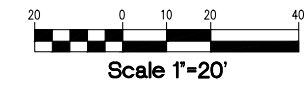

LEGEND

- PROPERTY LINE
- - - EX CONTOUR (INDEX)
- - - EX CONTOUR
- - - 230 PROPOSED CONTOUR (INDEX)
- - - 231 PROPOSED CONTOUR
- xxx SPOT ELEVATION
- FF 78.0 FINISHED FLOOR ELEVATION
- EX BUILDING
- PROPOSED BUILDING
- CONCRETE PAVEMENT
- HEAVY DUTY CONCRETE PAVEMENT
- SCORED CONCRETE
- ASPHALT (AC) PAVEMENT
- GRAVEL SURFACING
- SITE WALL
- VERTICAL CURB
- ROCKERY
- AREA DRAIN
- TRENCH DRAIN
- CATCH BASIN TYPE 1
- STORM DRAINAGE PIPE
- FOOTING/SUBSURFACE DRAIN
- SDCO = STORM DRAIN CLEANOUT
- FDCO = FOOTING DRAIN CLEANOUT
- DS = DOWNSPOUTS
- SS = SIDE SEWER PIPE
- SEWER CLEANOUT
- SIDE SEWER CONNECTION
- WATER FITTINGS
- WATER SERVICE LINES
- WATER METER
- WATER SERVICE LINES

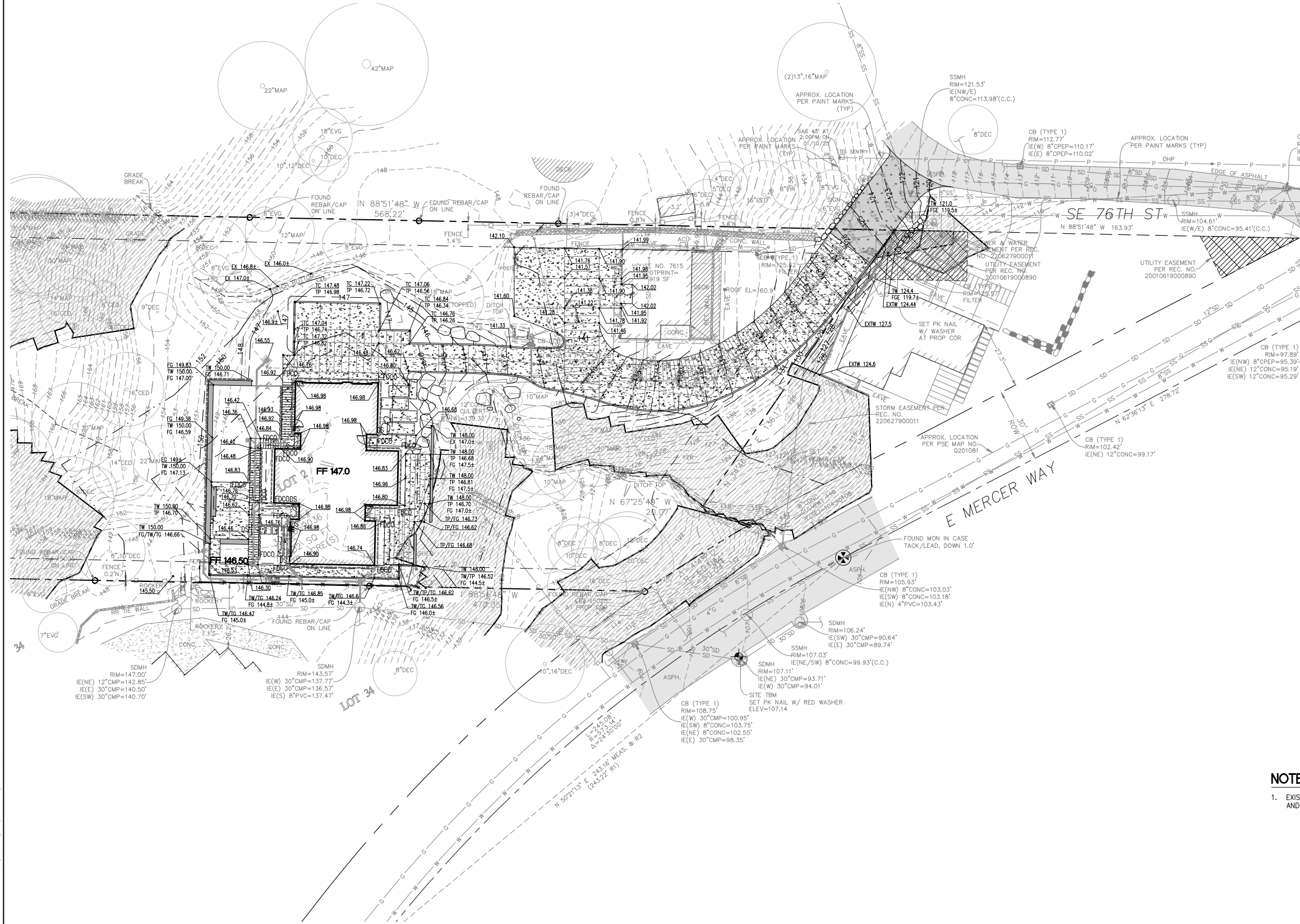

NOTES

1. EXISTING CUT MATERIAL SHALL NOT BE REUSED AS FILL ONSITE AND SHALL BE DISPOSED OFFSITE.

**LPD** engineering pllc  
 1932 First Ave,  
 Suite 500,  
 Seattle, WA 98101  
 p. 206.725.1211  
 f. 206.973.5344  
 www.lpdengineering.com



No.	Revisions	Date
REV2	BUILDING PERMIT CITY CORRECTIONS	2025-06-27

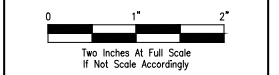

Project Name

**CHESHIRE RESIDENCE  
 7615 E. MERCER WAY**  
 City of Mercer Island, Washington

Project No.	
Issue Date	MARCH 07, 2025
Scale	As Noted
Designed	ACW
Checked	LJP
Drawn	SBR
Approved	LJP

GRADING PLAN

Sheet  
**C2.0**

**Call 3 Working Days  
 Before You Dig!**  
  
 1-800-424-5555

PERMIT SET

Section 30, Township 24N, range 5E W.M.

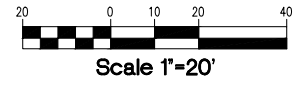

LEGEND

- PROPERTY LINE
- - - 230 EX CONTOUR (INDEX)
- - - 231 EX CONTOUR
- - - 230 PROPOSED CONTOUR (INDEX)
- - - 231 PROPOSED CONTOUR
- FF 78.0 FINISHED FLOOR ELEVATION
- [Hatched] EX BUILDING
- [Hatched] PROPOSED BUILDING
- [Dotted] CONCRETE PAVEMENT
- [Dotted] HEAVY DUTY CONCRETE PAVEMENT
- [Dotted] SCORED CONCRETE
- [Dotted] ASPHALT (AC) PAVEMENT
- [Dotted] GRAVEL SURFACING
- [Solid] SITE WALL
- [Dashed] VERTICAL CURB
- [Dashed] ROCKERY
- [Square] AREA DRAIN
- [Square] TRENCH DRAIN
- [Square] CATCH BASIN TYPE 1
- [Line with arrow] STORM DRAINAGE PIPE
- [Dashed] FOOTING/SUBSURFACE DRAIN
- [Circle with dot] SDCO • STORM DRAIN CLEANOUT
- [Circle with dot] FDCO • FOOTING DRAIN CLEANOUT
- [Circle with dot] DS • DOWNSPOUTS
- [Line] SIDE SEWER PIPE
- [Line] SEWER CLEANOUT
- [Line] SIDE SEWER CONNECTION
- [Line] WATER FITTINGS
- [Line] WATER SERVICE LINES
- [Line] WATER METER
- [Line] WATER SERVICE LINES

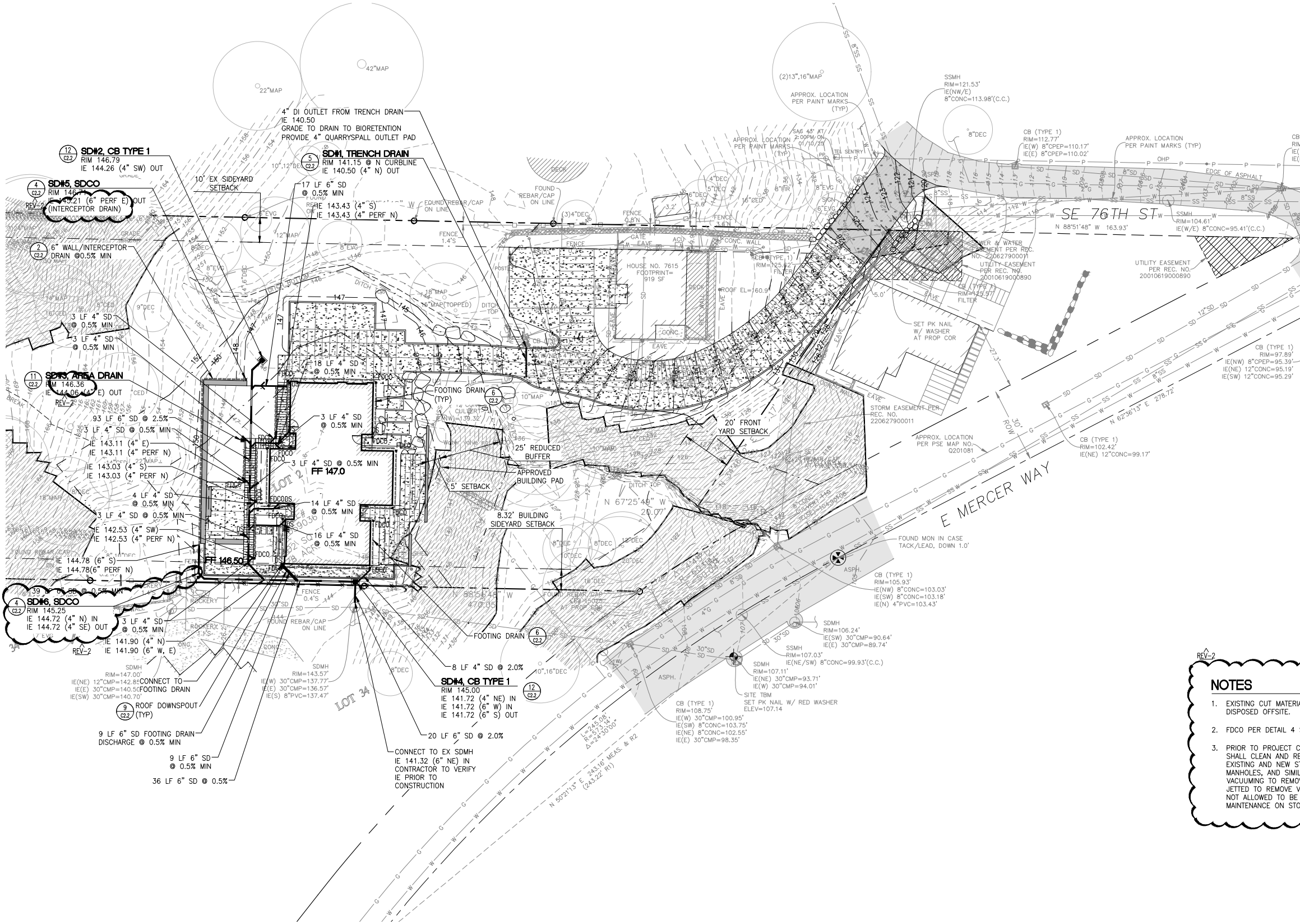

- NOTES**
- EXISTING CUT MATERIAL SHALL NOT BE REUSED AS FILL ONSITE AND SHALL BE DISPOSED OFFSITE.
  - FDCO PER DETAIL 4 SHEET C2.2
  - PRIOR TO PROJECT COMPLETION AND AFTER SITE IS STABILIZED, THE CONTRACTOR SHALL CLEAN AND REMOVE ALL SEDIMENT AND DEBRIS FROM ENTIRE ONSITE. EXISTING AND NEW STORMWATER SYSTEMS, ALL AREA DRAINS, CATCH BASINS, MANHOLES, AND SIMILAR STRUCTURES SHALL BE CLEANED BY RINSING AND VACUUMING TO REMOVE VISIBLE SEDIMENTS. ALL STORMWATER PIPES SHALL BE JETTED TO REMOVE VISIBLE SEDIMENTS. WASH WATER SHALL BE VACTORED AND NOT ALLOWED TO BE FLUSHED DOWNSTREAM. CONTRACTOR SHALL PROVIDE MAINTENANCE ON STORMFILTER PER MANUFACTURER RECOMMENDATIONS.



No.	Revisions	Date
REV2	BUILDING PERMIT CITY CORRECTIONS	2025-06-27

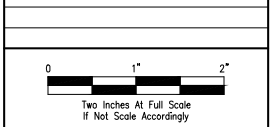

Project Name

**CHESHIRE RESIDENCE  
7615 E. MERCER WAY**  
City of Mercer Island, Washington

Project No.	
Issue Date	MARCH 07, 2025
Scale	As Noted
Designed	ACW
Drawn	SBR
Checked	LJP
Approved	LJP

**DRAINAGE PLAN**

PERMIT SET  
Sheet  
**C2.1**

Call 3 Working Days Before You Dig!  
1-800-424-5555

c:\lpd\engineering\plc\projects\cheshire\_residence\design\cheshire\_residence.dwg - cheshire.dwg - shome 6/27/2025 4:10 PM

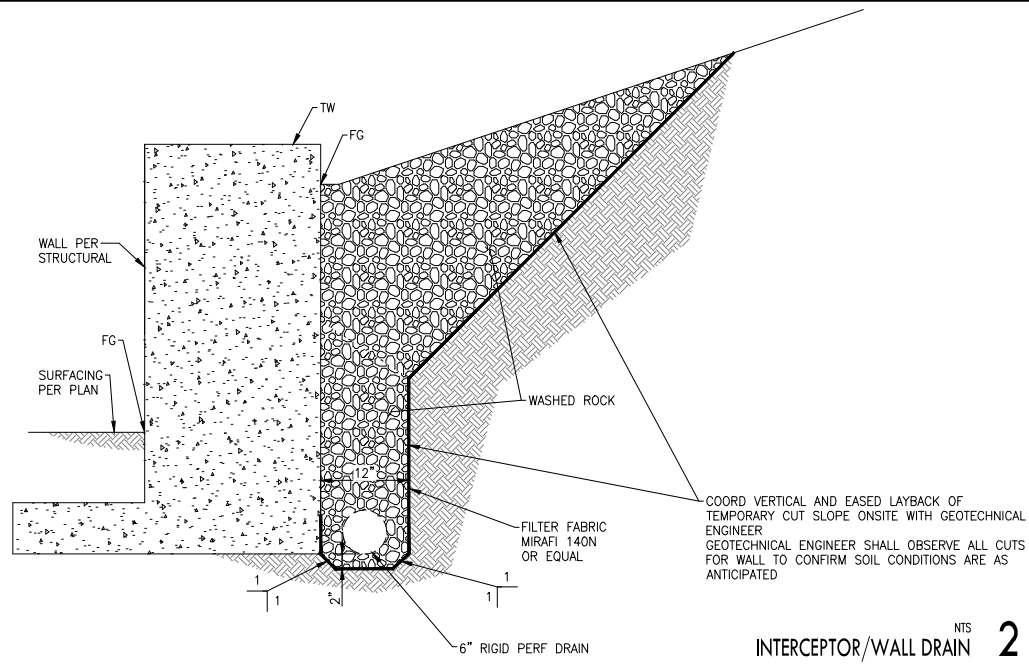

INTERCEPTOR/WALL DRAIN NTS 2

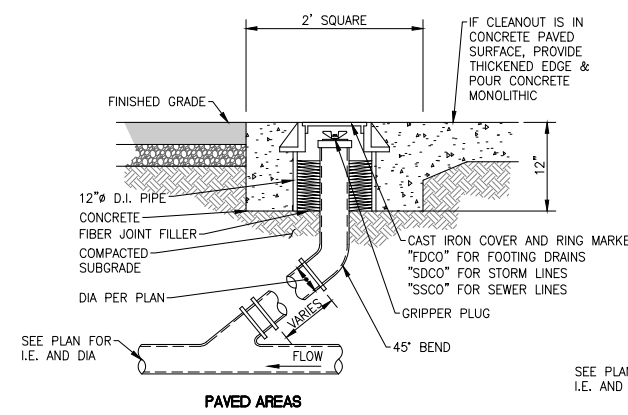

PAVED AREAS

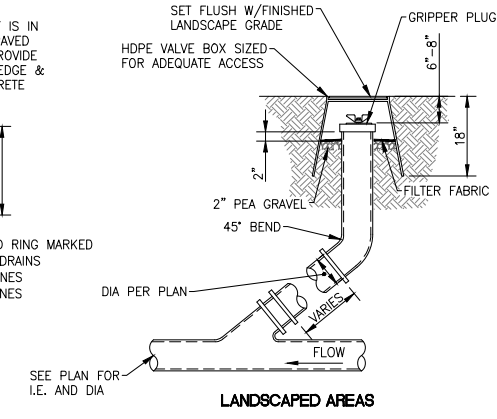

LANDSCAPED AREAS

CLEANOUT NTS 4

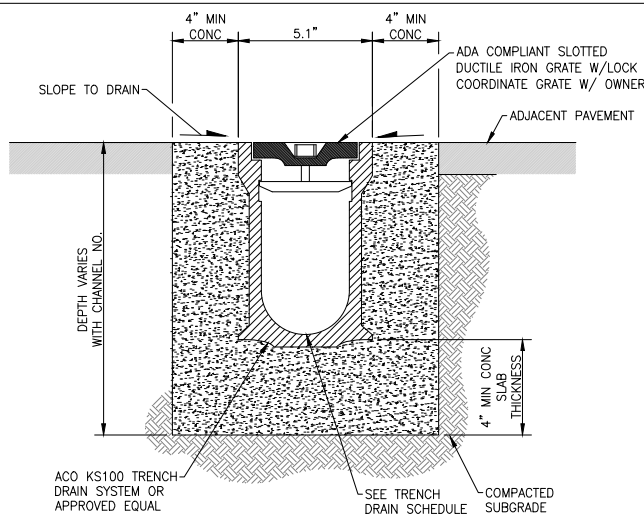

TRENCH DRAIN SCHEDULE

SD#1: K1-020 THROUGH K-0203 (NEUTRAL) CHANNELS SLOPE W/ PAVEMENT.  
TRENCH NUMBERS LISTED ABOVE ARE PER ACO KS100 TRENCH DRAIN.

TRENCH DRAIN NTS 5

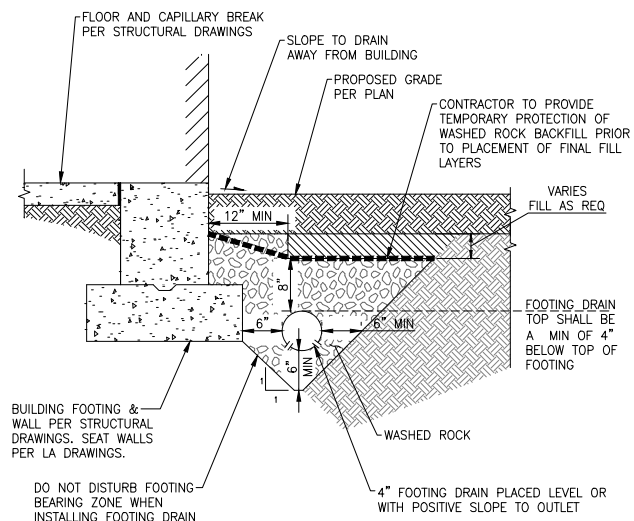

FOOTING DRAIN NTS 6

NOTES:

- CATCH BASINS SHALL BE CONSTRUCTED IN ACCORDANCE WITH ASTM C478 (AASHTO M 199) & C890 UNLESS OTHERWISE SHOWN ON PLANS OR NOTED IN THE WSDOT/APWA STANDARD SPECIFICATIONS.
- AS AN ACCEPTABLE ALTERNATIVE TO REBAR, WELDED WIRE FABRIC HAVING A MIN. AREA OF 0.12 SQUARE INCHES PER FOOT MAY BE USED. WELDED WIRE FABRIC SHALL COMPLY TO ASTM A497 (AASHTO M 221). WIRE FABRIC SHALL NOT BE PLACED IN KNOCKOUTS.
- ALL REINFORCED CAST-IN-PLACE CONCRETE SHALL BE CLASS 4000.
- PRECAST BASES SHALL BE FURNISHED WITH CUTOUTS OR KNOCKOUTS. KNOCKOUTS SHALL HAVE A WALL THICKNESS OF 2" MIN. ALL PIPE SHALL BE INSTALLED IN FACTORY PROVIDED KNOCKOUTS. UNUSED KNOCKOUTS NEED NOT BE GROUTED IF WALL IS LEFT INTACT.
- ROUND KNOCKOUTS MAY BE ON ALL 4 SIDES, WITH MAX. DIA. OF 20". KNOCKOUTS MAY BE EITHER ROUND OR "D" SHAPE.
- KNOCKOUT OR CUTOUT HOLE SIZE IS EQUAL TO PIPE OUTER DIA. PLUS CATCH BASIN WALL THICKNESS.
- THE MAX. DEPTH FROM THE FINISHED GRADE TO THE PIPE INVERT IS 5'-0".
- THE TAPER ON THE SIDES OF THE PRECAST BASE SECTION AND RISER SECTION SHALL NOT EXCEED 1/2"/FT.
- CATCH BASIN FRAME AND GRATE SHALL BE IN ACCORDANCE WITH STANDARD SPECIFICATIONS AND MEET THE STRENGTH REQUIREMENTS OF FEDERAL SPECIFICATION RR-F-62ID. MATING SURFACES SHALL BE FINISHED TO ASSURE NON-ROCKING FIT WITH ANY COVER POSITION.
- FRAME AND GRATE MAY BE INSTALLED WITH FLANGE DOWN OR CAST INTO RISER.
- FOR CATCH BASINS IN PARKING LOTS REFER TO WSDOT STD PLAN B-5.60-01.
- EDGE OF RISER OR BRICK SHALL NOT BE MORE THAN 2" FROM VERTICAL EDGE OF CATCH BASIN WALL.
- CATCH BASIN INSTALLATION SHALL BE PER CONTRACT DOCUMENTS AND DETAILS.

FRAME AND GRATE SEE APPLICABLE DWGS.

GRATES IN WALKWAYS AND PEDESTRIAN AREAS SHALL BE ACCESSIBLE INSTALL GRATE PER WSDOT STD PLAN B-30.15.00. SEE PLAN FOR ALTERNATES.

ADA REQUIREMENTS FOR GRATES: OPENINGS MUST NOT EXCEED 1/2" IN WIDTH IN THE DIRECTION OF TRAVEL. COEFFICIENT OF FRICTION MUST BE AT LEAST 0.6

6" RISER SECTION

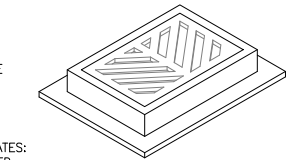

1 #3 BAR HOOP

12" RISER SECTION

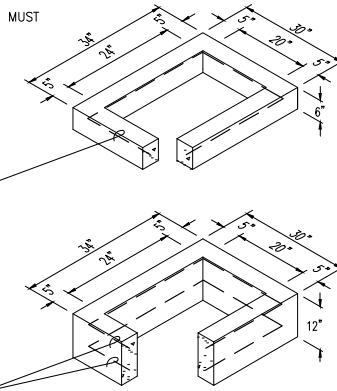

2 #3 BAR HOOP

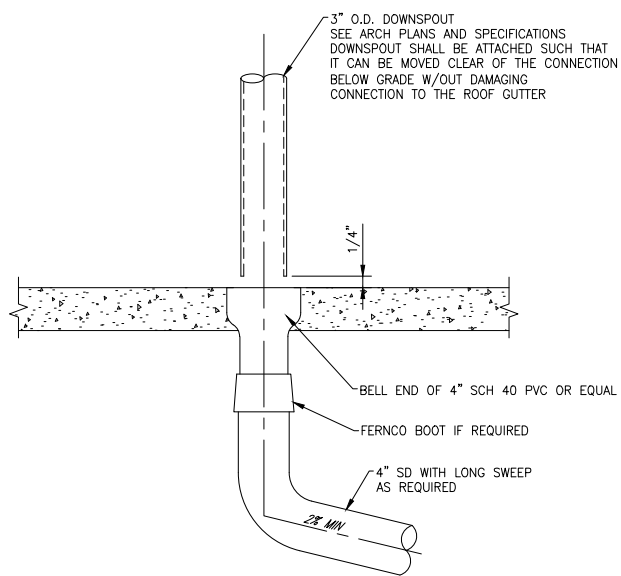

RESIDENTIAL ROOF DOWNSPOUT NTS 9

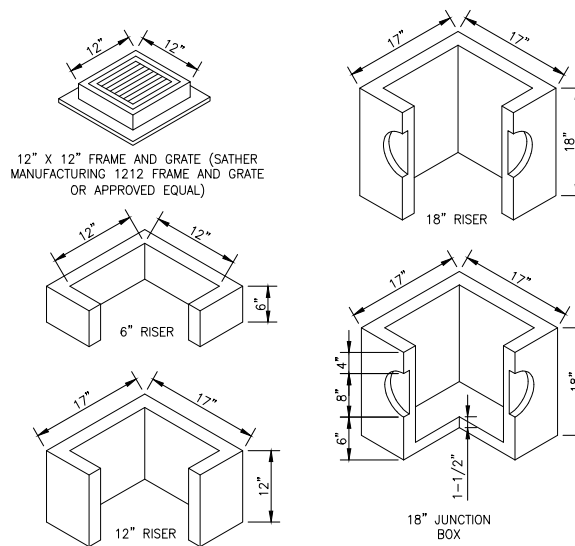

17" X 17" AREA DRAIN BY CUZ CONCRETE PRODUCTS OR EQUAL

AREA DRAIN NTS 11

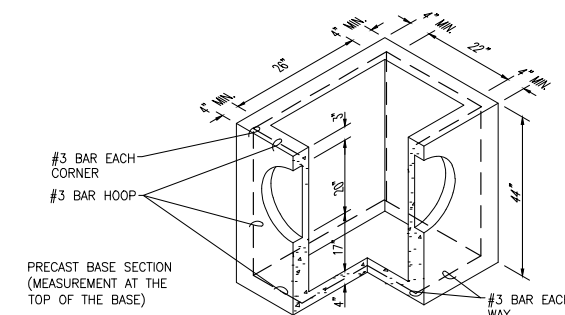

CATCH BASIN TYPE 1 NTS 12



No.	Revisions	Date
REV2	BUILDING PERMIT CITY CORRECTIONS	2025-06-27

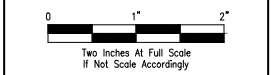

Project Name

CHESHIRE RESIDENCE  
7615 E. MERCER WAY  
City of Mercer Island, Washington

Project No.	
Issue Date	MARCH 07, 2025
Scale	As Noted
Designed	ACW
Checked	LJP
Drawn	SBR
Approved	LJP

GRADING AND DRAINAGE DETAILS

Sheet C2.2

PERMIT SET

Section 30, Township 24N, range 5E W.M.

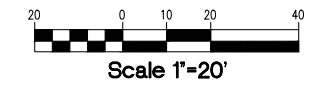

LEGEND

- PROPERTY LINE
- - - - - 230 EX CONTOUR (INDEX)
- - - - - 231 EX CONTOUR
- - - - - 230 PROPOSED CONTOUR (INDEX)
- - - - - 231 PROPOSED CONTOUR
- FF 78.0** FINISHED FLOOR ELEVATION
- [Hatched] EX BUILDING
- [Hatched] PROPOSED BUILDING
- [Dotted] CONCRETE PAVEMENT
- [Dotted] HEAVY DUTY CONCRETE PAVEMENT
- [Dotted] SCORED CONCRETE
- [Hatched] ASPHALT (AC) PAVEMENT
- [Dotted] GRAVEL SURFACING
- [Solid] SITE WALL
- [Dashed] VERTICAL CURB
- [Dashed] ROCKERY
- [Square] AREA DRAIN
- [Line] TRENCH DRAIN
- [Square] CATCH BASIN TYPE 1
- [Line] STORM DRAINAGE PIPE
- [Dashed] FOOTING/SUBSURFACE DRAIN
- [Dashed] STORM DRAIN CLEANOUT
- [Dashed] FOOTING DRAIN CLEANOUT
- [Dashed] DOWNSPOUTS
- [Line] SS CO SIDE SEWER PIPE
- [Line] SEWER CLEANOUT
- [Line] SIDE SEWER CONNECTION
- [Line] WATER FITTINGS
- [Line] WATER SERVICE LINES
- [Line] WATER METER
- [Line] WATER SERVICE LINES

**LPD** engineering pllc  
 1932 First Ave,  
 Suite 500,  
 Seattle, WA 98101  
 p. 206.725.1211  
 f. 206.973.5344  
 www.lpdengineering.com



No.	Revisions	Date
REV2	BUILDING PERMIT CITY CORRECTIONS	2025-06-27

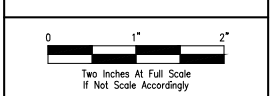

Project Name

**CHESHIRE RESIDENCE  
 7615 E. MERCER WAY**  
 City of Mercer Island, Washington

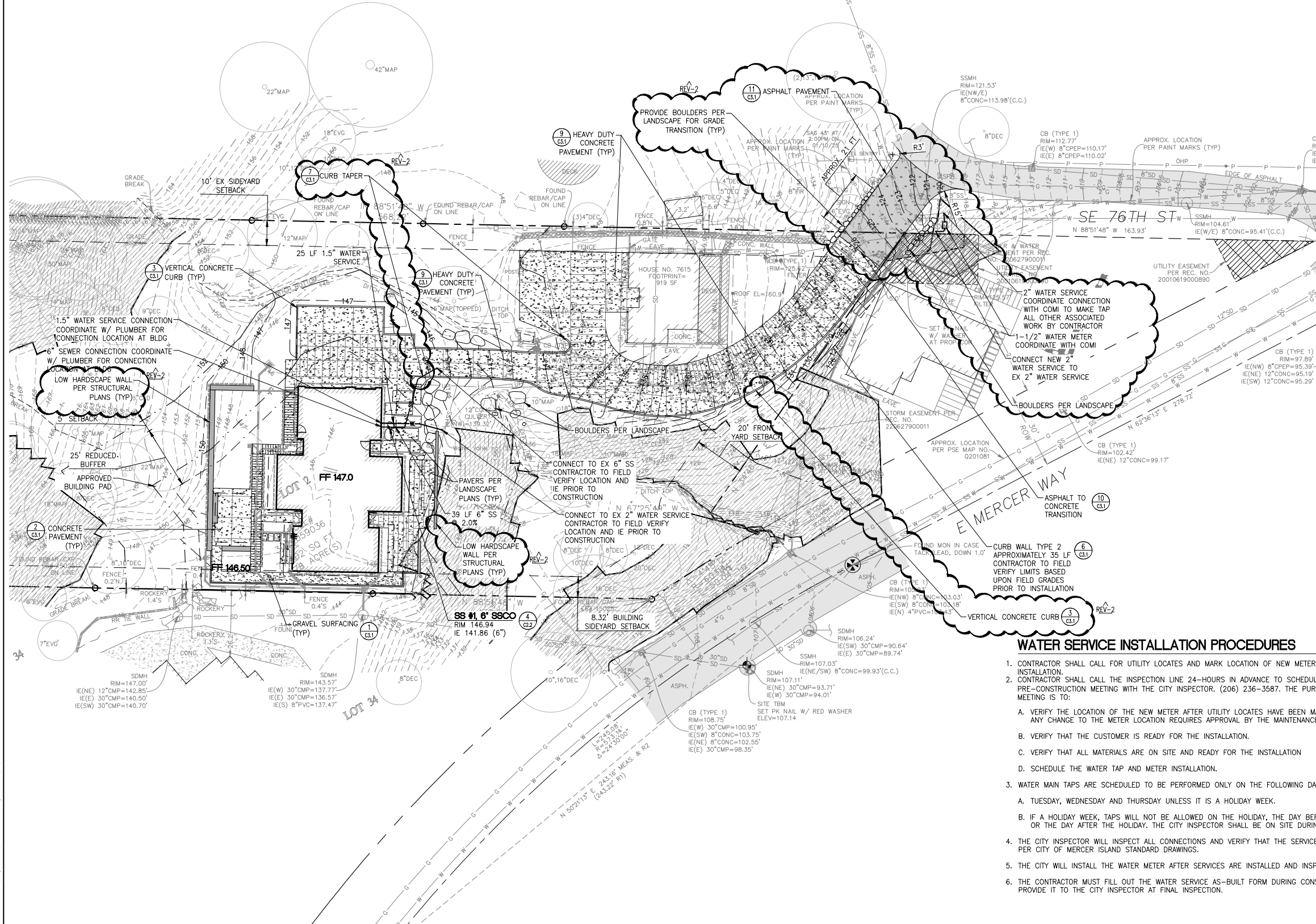

**WATER SERVICE INSTALLATION PROCEDURES**

1. CONTRACTOR SHALL CALL FOR UTILITY LOCATES AND MARK LOCATION OF NEW METER INSTALLATION.
2. CONTRACTOR SHALL CALL THE INSPECTION LINE 24-HOURS IN ADVANCE TO SCHEDULE A PRE-CONSTRUCTION MEETING WITH THE CITY INSPECTOR. (206) 236-3587. THE PURPOSE OF THE MEETING IS TO:
  - A. VERIFY THE LOCATION OF THE NEW METER AFTER UTILITY LOCATES HAVE BEEN MARKED. ANY CHANGE TO THE METER LOCATION REQUIRES APPROVAL BY THE MAINTENANCE DEPARTMENT.
  - B. VERIFY THAT THE CUSTOMER IS READY FOR THE INSTALLATION.
  - C. VERIFY THAT ALL MATERIALS ARE ON SITE AND READY FOR THE INSTALLATION
  - D. SCHEDULE THE WATER TAP AND METER INSTALLATION.
3. WATER MAIN TAPS ARE SCHEDULED TO BE PERFORMED ONLY ON THE FOLLOWING DAYS:
  - A. TUESDAY, WEDNESDAY AND THURSDAY UNLESS IT IS A HOLIDAY WEEK.
  - B. IF A HOLIDAY WEEK, TAPS WILL NOT BE ALLOWED ON THE HOLIDAY, THE DAY BEFORE OR THE DAY AFTER THE HOLIDAY. THE CITY INSPECTOR SHALL BE ON SITE DURING ALL WATER TAPS.
4. THE CITY INSPECTOR WILL INSPECT ALL CONNECTIONS AND VERIFY THAT THE SERVICES ARE INSTALLED PER CITY OF MERCER ISLAND STANDARD DRAWINGS.
5. THE CITY WILL INSTALL THE WATER METER AFTER SERVICES ARE INSTALLED AND INSPECTED.
6. THE CONTRACTOR MUST FILL OUT THE WATER SERVICE AS-BUILT FORM DURING CONSTRUCTION AND PROVIDE IT TO THE CITY INSPECTOR AT FINAL INSPECTION.

**Call 3 Working Days  
 Before You Dig!**  
  
 1-800-424-5555

PERMIT SET

Project No.	
Issue Date	MARCH 07, 2025
Scale	As Noted
Designed	ACW
Checked	LJP
Drawn	SBR
Approved	LJP

Description  
**UTILITIES  
 AND  
 PAVING  
 PLAN**  
 Sheet  
**C3.0**

© LPD engineering pllc | projects | cheshire residence | design | laurie pearl | 06/27/2025 | 4:10 PM

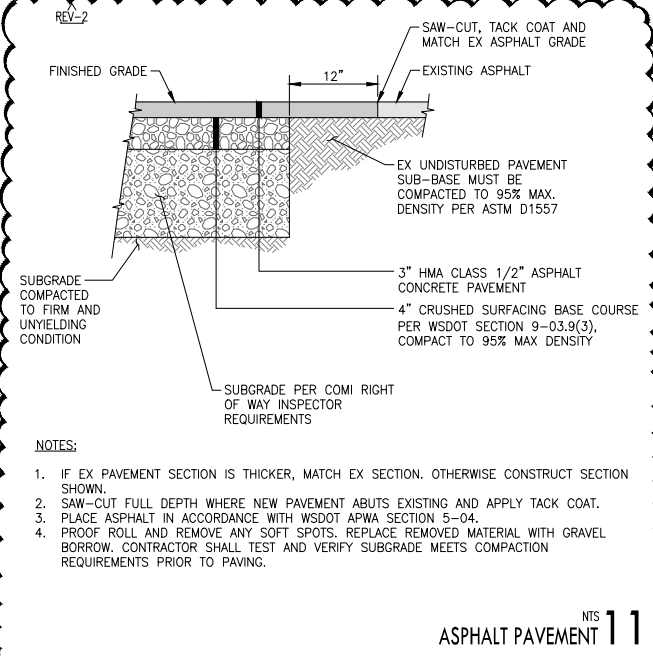
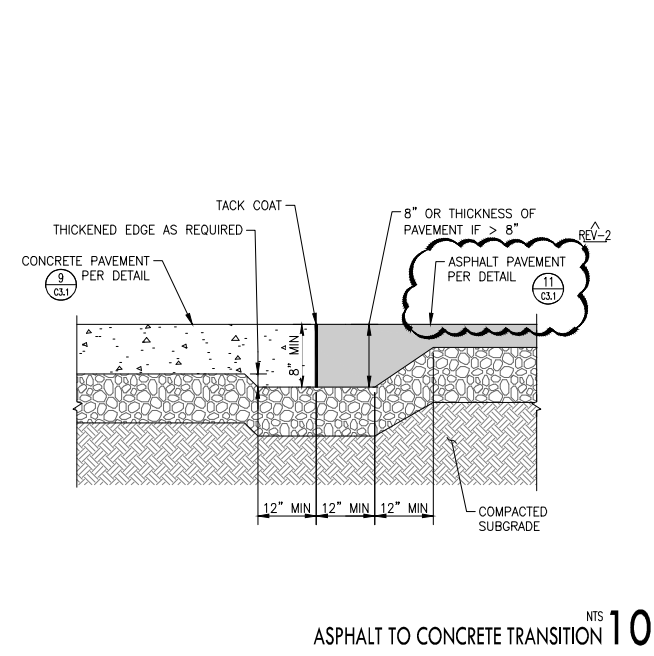
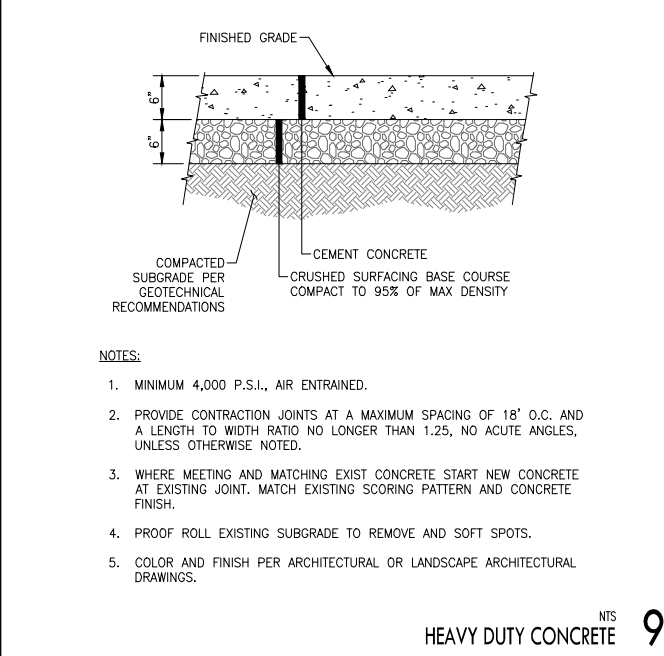
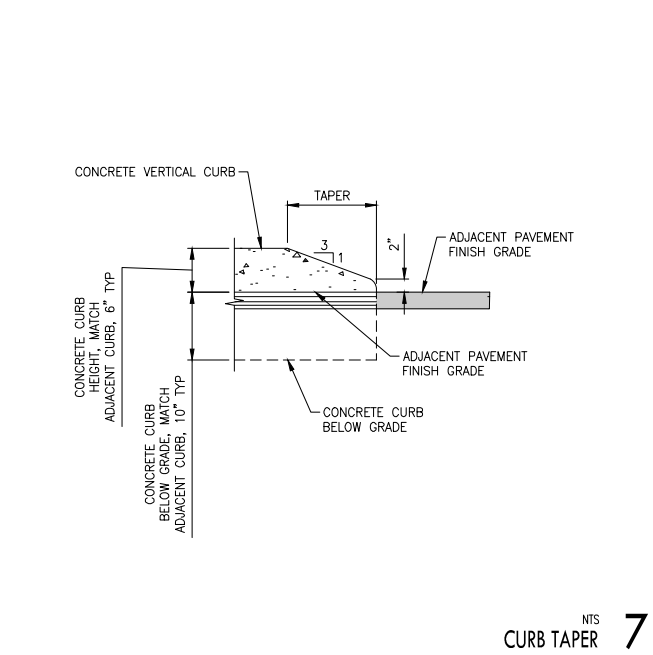
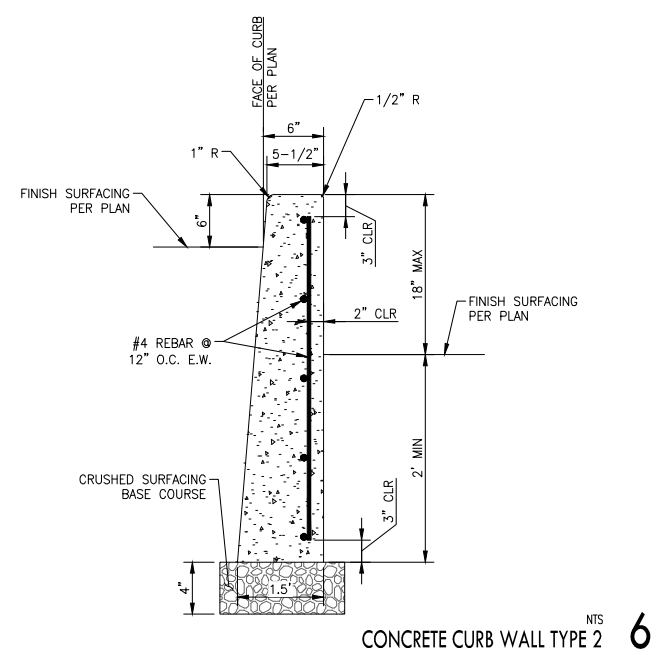
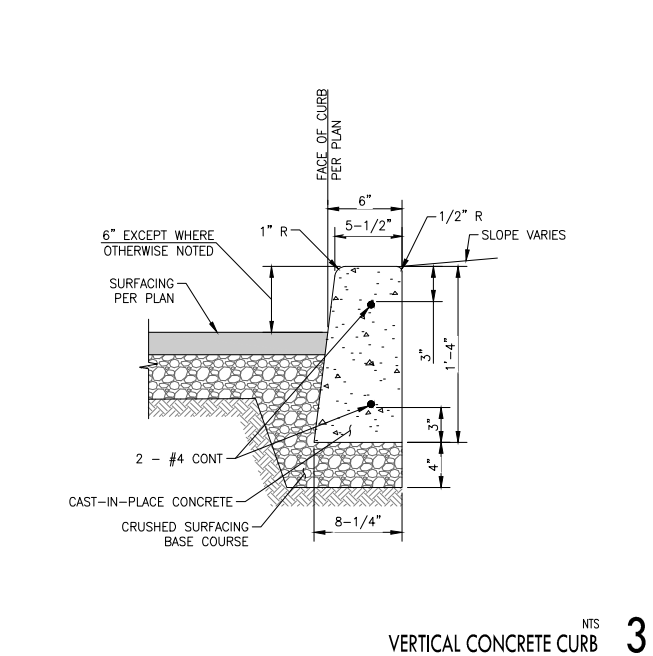
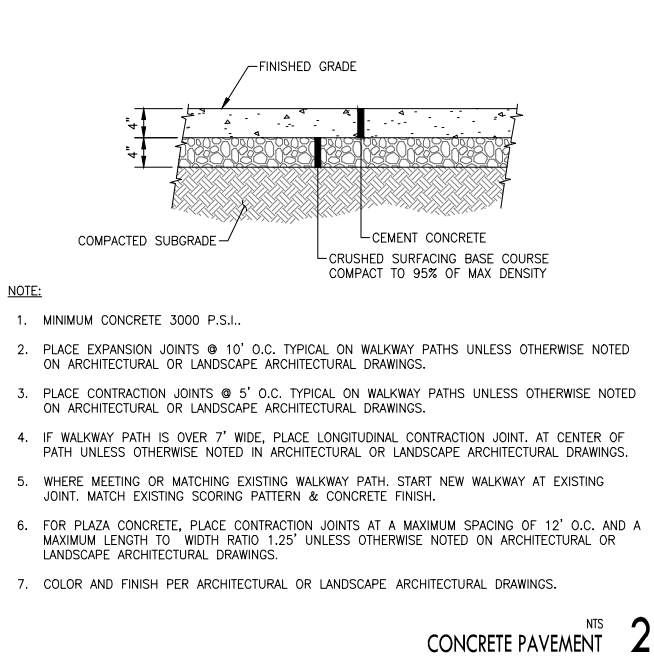
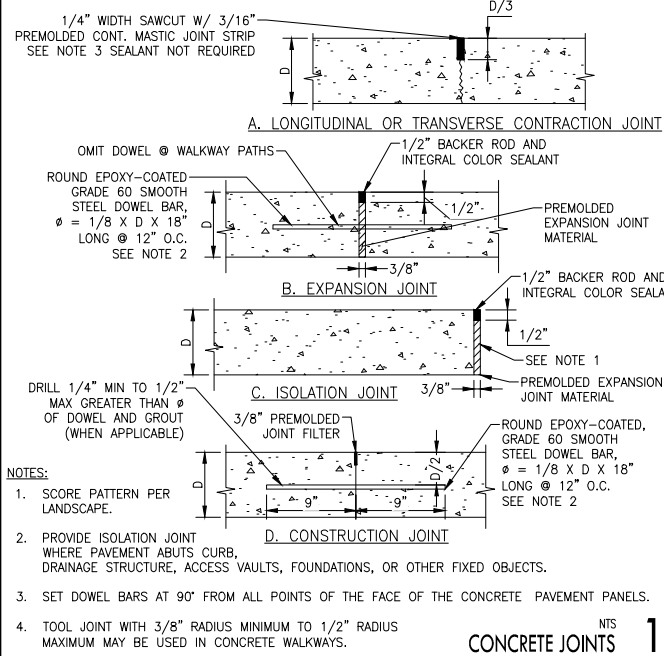

**CITY OF MERCER ISLAND UTILITY NOTES**

- ALL STAGING AND STORAGE SHALL OCCUR ON SITE.
- A REDUCED PRESSURE BACKFLOW ASSEMBLY (RPBA) INSTALLATION SHALL BE REQUIRED AND INSTALLED 12 INCHES ABOVE GRADE BEHIND THE WATER METER FOR ALL NEW AND DEMO REBUILD SINGLE FAMILY, LAKEFRONT PROJECTS. THE RPBA SHALL BE INSPECTED AT TIME OF INSTALLATION AND AT BUILDING FINAL. (A HOT BOX TO PROTECT THE RPBA ASSEMBLY IS OPTIONAL.) A DOUBLE CHECK VALVE ASSEMBLY (DCVA) IS REQUIRED ON ALL FIRE SPRINKLER SYSTEMS.
- POT HOLE THE PUBLIC UTILITIES IS REQUIRED PRIOR TO ANY GRADING ACTIVITIES LESS THAN 6" OVER THE PUBLIC MAINS (WATER, SEWER AND STORM SYSTEMS). IF THERE IS A CONFLICT, THE APPLICANT IS REQUIRED TO SUBMIT A REVISION FOR APPROVAL PRIOR TO ANY GRADING ACTIVITIES OVER THE PUBLIC MAINS.
- DO NOT BACKFILL WITH NATIVE MATERIAL ON PUBLIC RIGHT OF WAY. ALL MATERIAL MUST BE IMPORTED.
- REFER TO WATER SERVICE PERMIT FOR ACTUAL LOCATION OF NEW WATER METER AND SERVICE LINE DETERMINED BY MERCER ISLAND WATER DEPARTMENT.
- THE EXISTING WATER SERVICE MUST BE ABANDONED AT THE CITY WATER MAIN WHEN A NEW SERVICE IS INSTALLED. THE HOMEOWNER IS RESPONSIBLE FOR ALL COST ASSOCIATED WITH THE ABANDONMENT OF THE EXISTING WATER SERVICE.
- NO ADS FLEXIBLE PIPE SHALL BE ALLOWED.
- SAND COLLARS ARE REQUIRED FOR GROUTING PVC PIPE TO CONCRETE STRUCTURES. THIS ALSO APPLIES TO ADS N-12 PIPES AND HDPE PIPES.
- OWNER SHALL CONTROL DISCHARGE OF SURFACE DRAINAGE RUNOFF FROM EXISTING AND NEW IMPERVIOUS AREAS IN A RESPONSIBLE MANNER. CONSTRUCTION OF NEW GUTTERS AND DOWNSPOUTS, DRY WELLS, LEVEL SPREADERS OR DOWNSTREAM CONVEYANCE PIPE MAY BE NECESSARY TO MINIMIZE DRAINAGE IMPACT TO YOUR NEIGHBORS. CONSTRUCTION OF MINIMUM DRAINAGE IMPROVEMENTS SHOWN OR CALLED OUT ON THE PLAN DOES NOT IMPLY RELIEF FROM CIVIL LIABILITY FOR YOUR DOWNSTREAM DRAINAGE.
- THE CONTRACTOR MUST POT HOLE ALL UTILITIES PRIOR TO MAKING CONNECTIONS TO VERIFY MATERIAL, DIAMETER, ALIGNMENTS, ETC. PRIOR TO MAKING CONNECTIONS, CONTRACTOR SHALL HAVE ALL NECESSARY PARTS, MATERIALS AND EQUIPMENT ON SITE. CONTACT SITE & UTILITIES INSPECTOR TO VERIFY.
- CATCH BASIN FILTERS SHOULD BE PROVIDED FOR ALL STORM DRAIN CATCH BASINS/INLETS DOWNSLOPE AND WITHIN 500 FEET OF THE CONSTRUCTION AREA. CATCH BASIN FILTERS SHOULD BE DESIGNED BY THE MANUFACTURER FOR USE AT CONSTRUCTION SITES AND APPROVED BY THE CITY INSPECTOR. CATCH BASIN FILTERS SHOULD BE INSPECTED FREQUENTLY, ESPECIALLY AFTER STORM EVENTS. IF THE FILTER BECOMES CLOGGED, IT SHOULD BE CLEANED OR REPLACED.
- THE TV INSPECTION OF THE EXISTING SIDE SEWER TO THE CITY SEWER MAIN IS REQUIRED. IF THE RESULT OF THE TV INSPECTION IS NOT IN SATISFACTORY CONDITION BY THE CITY OF MERCER ISLAND INSPECTOR, THE REPLACEMENT OF THE EXISTING SIDE SEWER IS REQUIRED.
- INFORM THE MERCER ISLAND CITY SITE/UTILITY INSPECTOR AT 206.275-7714 OF THE ANTICIPATED START DATE OF IN-WATER WORK PRIOR TO COMMENCEMENT OF CONSTRUCTION.
- FIELD LOCATE THE SEWER MAIN (LAKELINE) UNDERLYING THE LAKEBED AND MARK CLEARLY PRIOR TO THE START OF CONSTRUCTION. CONTACT THE MERCER ISLAND SITE/UTILITY INSPECTOR AT (206)275-7714 FOR AVAILABLE INFORMATION ABOUT THE LAKELINE AND ASSISTANCE WHERE POSSIBLE WITH IDENTIFYING THE GENERAL LOCATION OF THE LAKELINE PRIOR TO CONSTRUCTION. GIS MAPPING MAY BE AVAILABLE BY CALLING (206)236-3471. THE APPLICANT SHALL BE RESPONSIBLE FOR ANY DAMAGE TO SAID SEWER MAIN RESULTING FROM CONSTRUCTION.
- ALL WATER LINES SHALL HAVE A MINIMUM 42" OF COVER FROM FINISHED GRADE.

**CITY OF MERCER ISLAND UTILITY NOTES** 8

**PERMIT SET**

Project No. \_\_\_\_\_

Issue Date: MARCH 07, 2025

Scale: As Noted

Designed: ACW Checked: LJP

Drawn: SBR Approved: LJP

Description: UTILITIES AND PAVING DETAILS

Sheet: C3.1

NOT USED 12

**LPD** engineering pllc 1932 First Ave, Suite 500, Seattle, WA 98101 p. 206.725.1211 f. 206.973.5344 www.lpdengineering.com

Stamp: LAURIE J. PEARL PROFESSIONAL ENGINEER 06-27-25

Revisions Table:

No.	Revisions	Date
REV2	BUILDING PERMIT CITY CORRECTIONS	2025-06-27

Scale: 0 1" 2" Two Inches At Full Scale If Not Scale Accordingly

Project Name: CHESHIRE RESIDENCE 7615 E. MERCER WAY City of Mercer Island, Washington

c:\lpd\engineering\pllc\projects\lakebed\residence\design\lakeside\utilities\_details\cheshire.dwg shinn 6/27/2025 4:19 PM



## **APPENDIX B**

### Design Calculations and Supporting Information

Cheshire Residence  
 Conveyance Analysis Spreadsheet

6/28/2023

Pipe Run	Size <i>(inches)</i>	Mannings N	Plan Slope <i>(ft/ft)</i>	Qfull <i>(cfs)</i>	Tributary Basins	Total Tributary Area <i>(acres)</i>	Tributary Impervious Area <i>(acres)</i>	Tributary Pervious Area <i>(acres)</i>	Qtrib, 25-year (MGSFlood, 15 min) <i>(cfs)</i>	% Full	Qtrib, 100-year (MGSFlood, 15 min) <i>(cfs)</i>	% Full
South Outlet	6	0.011	0.005	<b>0.470</b>	Roof, Walkways, Gravel, Lawn, Upstream Forested	0.916	0.140	0.776	<b>0.147</b>	<b>31%</b>	<b>0.187</b>	<b>40%</b>

---

# MGS FLOOD PROJECT REPORT

**Program Version: MGSFlood 4.64**  
**Program License Number: 201410003**  
**Project Simulation Performed on: 03/04/2025 10:30 AM**  
**Report Generation Date: 03/04/2025 10:31 AM**

---

Input File Name: Conveyance - Onsite.fld  
Project Name: Cheshire Residence  
Analysis Title: Conveyance - Onsite  
Comments:

---

## PRECIPITATION INPUT

---

Computational Time Step (Minutes): 15

Extended Precipitation Time Series Selected

Full Period of Record Available used for Routing

Climatic Region Number: 15  
Precipitation Station : 96004005 Puget East 40 in\_5min 10/01/1939-10/01/2097  
Evaporation Station : 961040 Puget East 40 in MAP

Evaporation Scale Factor : 0.750

HSPF Parameter Region Number: 1  
HSPF Parameter Region Name : Ecology Default

\*\*\*\*\* Default HSPF Parameters Used (Not Modified by User) \*\*\*\*\*

## \*\*\*\*\* WATERSHED DEFINITION \*\*\*\*\*

### Predevelopment/Post Development Tributary Area Summary

	Predeveloped	Post Developed
Total Subbasin Area (acres)	0.916	0.916
Area of Links that Include Precip/Evap (acres)	0.000	0.000
Total (acres)	0.916	0.916

## -----SCENARIO: PREDEVELOPED

Number of Subbasins: 1

----- Subbasin : Subbasin 1 -----  
-----Area (Acres) -----  
C, Forest, Flat 0.178  
C, Forest, Mod 0.738

-----  
Subbasin Total            0.916

-----**SCENARIO: POSTDEVELOPED**

Number of Subbasins: 1

----- Subbasin : Main Site -----  
                                  -----Area (Acres) -----  
C, Forest, Mod            0.738  
C, Lawn, Flat            0.038  
ROOF TOPS/FLAT            0.093  
SIDEWALKS/FLAT            0.047  
-----  
Subbasin Total            0.916

\*\*\*\*\* **LINK DATA** \*\*\*\*\*

-----**SCENARIO: PREDEVELOPED**

Number of Links: 0

\*\*\*\*\* **LINK DATA** \*\*\*\*\*

-----**SCENARIO: POSTDEVELOPED**

Number of Links: 1

-----  
**Link Name: Connection to Storm**

Link Type: Copy  
Downstream Link: None

\*\*\*\*\* **FLOOD FREQUENCY AND DURATION STATISTICS** \*\*\*\*\*

-----**SCENARIO: PREDEVELOPED**

Number of Subbasins: 1  
Number of Links: 0

-----**SCENARIO: POSTDEVELOPED**

Number of Subbasins: 1  
Number of Links: 1

\*\*\*\*\* **Groundwater Recharge Summary** \*\*\*\*\*

Recharge is computed as input to Perlnd Groundwater Plus Infiltration in Structures

Total Predeveloped Recharge During Simulation	
Model Element	Recharge Amount (ac-ft)
-----	
Subbasin: Subbasin 1	157.988

Total: 157.988

Total Post Developed Recharge During Simulation  
Model Element Recharge Amount (ac-ft)

-----  
Subbasin: Main Site 131.932  
Link: Connection to Storm 0.000

-----  
Total: 131.932

**Total Predevelopment Recharge is Greater than Post Developed  
Average Recharge Per Year, (Number of Years= 158)  
Predeveloped: 1.000 ac-ft/year, Post Developed: 0.835 ac-ft/year**

**\*\*\*\*\*Water Quality Facility Data \*\*\*\*\***

-----**SCENARIO: PREDEVELOPED**

Number of Links: 0

-----**SCENARIO: POSTDEVELOPED**

Number of Links: 1

\*\*\*\*\* Link: Connection to Storm \*\*\*\*\*

2-Year Discharge Rate : 0.066 cfs

15-Minute Timestep, Water Quality Treatment Design Discharge

On-line Design Discharge Rate (91% Exceedance): 0.02 cfs

Off-line Design Discharge Rate (91% Exceedance): 0.01 cfs

Infiltration/Filtration Statistics-----

Inflow Volume (ac-ft): 137.49

Inflow Volume Including PPT-Evap (ac-ft): 137.49

Total Runoff Infiltrated (ac-ft): 0.00, 0.00%

Total Runoff Filtered (ac-ft): 0.00, 0.00%

Primary Outflow To Downstream System (ac-ft): 137.49

Secondary Outflow To Downstream System (ac-ft): 0.00

Volume Lost to ET (ac-ft): 0.00

Percent Treated (Infiltrated+Filtered+ET)/Total Volume: 0.00%

**\*\*\*\*\*Compliance Point Results \*\*\*\*\***

Scenario Predeveloped Compliance Subbasin: Subbasin 1

Scenario Postdeveloped Compliance Link: Connection to Storm

**\*\*\* Point of Compliance Flow Frequency Data \*\*\***

Recurrence Interval Computed Using Gringorten Plotting Position

Predevelopment Runoff

Postdevelopment Runoff

Tr (Years)	Discharge (cfs)	Tr (Years)	Discharge (cfs)
2-Year	1.952E-02	2-Year	6.646E-02
5-Year	3.181E-02	5-Year	8.873E-02
10-Year	4.170E-02	10-Year	0.109
25-Year	5.384E-02	25-Year	0.147
50-Year	6.689E-02	50-Year	0.175
100-Year	7.250E-02	100-Year	0.187
200-Year	0.111	200-Year	0.220
500-Year	0.164	500-Year	0.265

\*\* Record too Short to Compute Peak Discharge for These Recurrence Intervals

\*\*\*\* **Flow Duration Performance** \*\*\*\*

Excursion at Predeveloped 50%Q2 (Must be Less Than or Equal to 0%):	139.2%	FAIL
Maximum Excursion from 50%Q2 to Q2 (Must be Less Than or Equal to 0%):	268.1%	FAIL
Maximum Excursion from Q2 to Q50 (Must be less than 10%):	99999.0%	FAIL
Percent Excursion from Q2 to Q50 (Must be less than 50%):	100.0%	FAIL

-----  
FLOW DURATION DESIGN CRITERIA: FAIL  
-----

\*\*\*\* **LID Duration Performance** \*\*\*\*

Excursion at Predeveloped 8%Q2 (Must be Less Than 0%):	42.3%	FAIL
Maximum Excursion from 8%Q2 to 50%Q2 (Must be Less Than 0%):	139.2%	FAIL

-----  
LID DURATION DESIGN CRITERIA: FAIL  
-----

## Sediment Facility Sizing Calculations

Per the 2014 DOE Manual

Project Name: Cheshire Residence

### Required Sediment Facility Surface Area (SA):

$$SA = 2 \cdot Q / V_{sed}$$

Where: Q = 2-year developed flow rate from MGS Flood  
V<sub>sed</sub> = Settling Velocity (0.00096 ft/sec)

Calculation:

multiplier =	2	
Q =	0.1380	cfs
V <sub>sed</sub> =	0.00096	fps
<b>Required SA =</b>	<b>287.5</b>	<b>square feet</b>

### Equivalent Sediment Trap Volume:

To determine the minimum sediment trap volume, an equivalent sediment trap was sized based upon the required surface area.

Length of Top Surface Area =	16	feet
Width of Top Surface Area =	18	feet
Surface Area Provided =	288	square feet
Side Slope =	0	(H:1V)
Total Depth of Sediment Trap =	3.5	feet
Bottom Length of Sediment Trap =	16	feet
Bottom Width of Sediment Trap =	18	feet
Total pond Volume =	1008	cubic feet
	<b>7539.84</b>	<b>gallons</b>

---

# MGS FLOOD PROJECT REPORT

Program Version: MGSFlood 4.64  
Program License Number: 201410003  
Project Simulation Performed on: 03/07/2025 4:27 PM  
Report Generation Date: 03/07/2025 4:27 PM

---

Input File Name: TESC Sizing.fld  
Project Name: Cheshire Residence  
Analysis Title: TESC Sizing  
Comments:

---

## PRECIPITATION INPUT

---

Computational Time Step (Minutes): 15

Extended Precipitation Time Series Selected

Full Period of Record Available used for Routing

Climatic Region Number: 15  
Precipitation Station : 96004005 Puget East 40 in\_5min 10/01/1939-10/01/2097  
Evaporation Station : 961040 Puget East 40 in MAP

Evaporation Scale Factor : 0.750

HSPF Parameter Region Number: 1  
HSPF Parameter Region Name : Ecology Default

\*\*\*\*\* Default HSPF Parameters Used (Not Modified by User) \*\*\*\*\*

## \*\*\*\*\* WATERSHED DEFINITION \*\*\*\*\*

### Predevelopment/Post Development Tributary Area Summary

	Predeveloped	Post Developed
Total Subbasin Area (acres)	1.085	1.085
Area of Links that Include Precip/Evap (acres)	0.000	0.000
Total (acres)	1.085	1.085

## -----SCENARIO: PREDEVELOPED

Number of Subbasins: 1

----- Subbasin : Subbasin 1 -----  
-----Area (Acres) -----  
C, Forest, Steep 0.738  
C, Lawn, Flat 0.038

ROADS/FLAT	0.169
ROOF TOPS/FLAT	0.093
SIDEWALKS/FLAT	0.047

-----  
Subbasin Total            1.085

-----**SCENARIO: POSTDEVELOPED**

Number of Subbasins: 1

----- Subbasin : Subbasin 1 -----  
                                      -----Area (Acres) -----  
C, Forest, Steep            0.738  
C, Lawn, Flat                0.038  
ROADS/FLAT                 0.169  
ROOF TOPS/FLAT            0.093  
SIDEWALKS/FLAT            0.047  
-----  
Subbasin Total            1.085

\*\*\*\*\* **LINK DATA** \*\*\*\*\*

-----SCENARIO: PREDEVELOPED

Number of Links: 0

\*\*\*\*\* **LINK DATA** \*\*\*\*\*

-----SCENARIO: POSTDEVELOPED

Number of Links: 0

\*\*\*\*\* **FLOOD FREQUENCY AND DURATION STATISTICS** \*\*\*\*\*

-----SCENARIO: PREDEVELOPED

Number of Subbasins: 1

Number of Links: 0

-----SCENARIO: POSTDEVELOPED

Number of Subbasins: 1

Number of Links: 0

\*\*\*\*\* **Groundwater Recharge Summary** \*\*\*\*\*

Recharge is computed as input to PerInd Groundwater Plus Infiltration in Structures

Total Predeveloped Recharge During Simulation	
Model Element	Recharge Amount (ac-ft)
-----	
Subbasin: Subbasin 1	129.769
-----	
Total:	129.769

Model Element	Total Post Developed Recharge During Simulation Recharge Amount (ac-ft)
Subbasin: Subbasin 1	129.769
<b>Total:</b>	<b>129.769</b>

**Total Predevelopment Recharge Equals Post Developed  
Average Recharge Per Year, (Number of Years= 158)  
Predeveloped: 0.821 ac-ft/year, Post Developed: 0.821 ac-ft/year**

\*\*\*\*\***Water Quality Facility Data**\*\*\*\*\*

-----**SCENARIO: PREDEVELOPED**

Number of Links: 0

-----**SCENARIO: POSTDEVELOPED**

Number of Links: 0

\*\*\*\*\***Compliance Point Results**\*\*\*\*\*

Scenario Predeveloped Compliance Subbasin: Subbasin 1

Scenario Postdeveloped Compliance Subbasin: Subbasin 1

**\*\*\* Point of Compliance Flow Frequency Data \*\*\***  
Recurrence Interval Computed Using Gringorten Plotting Position

Predevelopment Runoff		Postdevelopment Runoff	
Tr (Years)	Discharge (cfs)	Tr (Years)	Discharge (cfs)
2-Year	0.138	2-Year	0.138
5-Year	0.178	5-Year	0.178
10-Year	0.221	10-Year	0.221
25-Year	0.285	25-Year	0.285
50-Year	0.378	50-Year	0.378
100-Year	0.409	100-Year	0.409
200-Year	0.426	200-Year	0.426
500-Year	0.448	500-Year	0.448

\*\* Record too Short to Compute Peak Discharge for These Recurrence Intervals

\*\*\*\* **Flow Duration Performance** \*\*\*\*

Excursion at Predeveloped 50%Q2 (Must be Less Than or Equal to 0%):	0.0%	FAIL
Maximum Excursion from 50%Q2 to Q2 (Must be Less Than or Equal to 0%):	0.2%	FAIL
Maximum Excursion from Q2 to Q50 (Must be less than 10%):	1.2%	PASS
Percent Excursion from Q2 to Q50 (Must be less than 50%):	1.8%	PASS

-----  
**FLOW DURATION DESIGN CRITERIA: FAIL**

---

**\*\*\*\* LID Duration Performance \*\*\*\***

Excursion at Predeveloped 8%Q2 (Must be Less Than 0%):	0.0%	FAIL
Maximum Excursion from 8%Q2 to 50%Q2 (Must be Less Than 0%):	0.0%	FAIL

---

LID DURATION DESIGN CRITERIA: FAIL

---

WWHM2012  
PROJECT REPORT - Bioretention

---

Project Name: Cheshire  
Site Name:  
Site Address:  
City :  
Report Date: 3/7/2025  
Gage : Seatac  
Data Start : 1948/10/01  
Data End : 2009/09/30  
Precip Scale: 1.00  
Version Date: 2023/03/31  
Version : 4.2.19

---

Low Flow Threshold for POC 1 : 50 Percent of the 2 Year

---

High Flow Threshold for POC 1: 50 year

---

**PREDEVELOPED LAND USE**

Name : Basin 1  
Bypass: No

GroundWater: No

<u>Pervious Land Use</u>	<u>acre</u>
Pervious Total	0
<u>Impervious Land Use</u>	<u>acre</u>
ROADS FLAT	0.0086
Impervious Total	0.0086
Basin Total	0.0086

---

Element Flows To:  
Surface                      Interflow                      Groundwater

---

**MITIGATED LAND USE**

Name : Basin 1  
Bypass: No

GroundWater: No

<u>Pervious Land Use</u>	<u>acre</u>
Pervious Total	0
<u>Impervious Land Use</u>	<u>acre</u>
ROADS FLAT	0.0086
Impervious Total	0.0086
Basin Total	0.0086

---

Element Flows To:

Surface	Interflow	Groundwater
Surface retention 1	Surface retention 1	

---

Name : Bioretention 1  
 Bottom Length: 3.00 ft.  
 Bottom Width: 4.00 ft.  
 Material thickness of first layer: 1.5  
 Material type for first layer: SMMWW 12 in/hr  
 Material thickness of second layer: 1  
 Material type for second layer: GRAVEL  
 Material thickness of third layer: 0  
 Material type for third layer: GRAVEL  
Underdrain used  
 Underdrain Diameter (feet): 0.33  
 Orifice Diameter (in.): 0.33  
 Offset (in.): 0.33  
 Flow Through Underdrain (ac-ft.): 1.631  
 Total Outflow (ac-ft.): 1.631  
 Percent Through Underdrain: 99.98  
Discharge Structure  
 Riser Height: 0.5 ft.  
 Riser Diameter: 12 in.

Element Flows To:

Outlet 1	Outlet 2
----------	----------

---

**Bioretention 1 Hydraulic Table**

<u>Stage(feet)</u>	<u>Area(ac.)</u>	<u>Volume(ac-ft.)</u>	<u>Discharge(cfs)</u>	<u>Infilt(cfs)</u>
0.0000	0.000275	0.000000	0.0000	0.0000
0.0389	0.000303	0.000005	0.0000	0.0000
0.0778	0.000332	0.000011	0.0000	0.0000
0.1167	0.000361	0.000017	0.0000	0.0000
0.1556	0.000393	0.000024	0.0000	0.0000
0.1944	0.000425	0.000031	0.0000	0.0000
0.2333	0.000459	0.000039	0.0000	0.0000
0.2722	0.000494	0.000047	0.0000	0.0000

0.3111	0.000530	0.000056	0.0000	0.0000
0.3500	0.000567	0.000066	0.0000	0.0000
0.3889	0.000606	0.000077	0.0000	0.0000
0.4278	0.000646	0.000088	0.0000	0.0000
0.4667	0.000687	0.000100	0.0000	0.0000
0.5056	0.000729	0.000112	0.0000	0.0000
0.5444	0.000773	0.000125	0.0000	0.0000
0.5833	0.000818	0.000140	0.0000	0.0000
0.6222	0.000864	0.000155	0.0000	0.0000
0.6611	0.000911	0.000170	0.0000	0.0000
0.7000	0.000960	0.000187	0.0000	0.0000
0.7389	0.001010	0.000205	0.0000	0.0000
0.7778	0.001061	0.000223	0.0000	0.0000
0.8167	0.001114	0.000242	0.0000	0.0000
0.8556	0.001167	0.000263	0.0000	0.0000
0.8944	0.001222	0.000284	0.0000	0.0000
0.9333	0.001278	0.000306	0.0000	0.0000
0.9722	0.001336	0.000329	0.0000	0.0000
1.0111	0.001394	0.000354	0.0000	0.0000
1.0500	0.001454	0.000379	0.0000	0.0000
1.0889	0.001515	0.000405	0.0000	0.0000
1.1278	0.001578	0.000433	0.0000	0.0000
1.1667	0.001641	0.000461	0.0000	0.0000
1.2056	0.001706	0.000491	0.0000	0.0000
1.2444	0.001772	0.000522	0.0000	0.0000
1.2833	0.001840	0.000554	0.0000	0.0000
1.3222	0.001909	0.000588	0.0000	0.0000
1.3611	0.001978	0.000622	0.0000	0.0000
1.4000	0.002050	0.000658	0.0000	0.0000
1.4389	0.002122	0.000695	0.0000	0.0000
1.4778	0.002196	0.000733	0.0000	0.0000
1.5167	0.002271	0.000769	0.0000	0.0000
1.5556	0.002347	0.000807	0.0000	0.0000
1.5944	0.002424	0.000845	0.0000	0.0000
1.6333	0.002503	0.000885	0.0000	0.0000
1.6722	0.002583	0.000926	0.0000	0.0000
1.7111	0.002664	0.000968	0.0000	0.0000
1.7500	0.002746	0.001012	0.0000	0.0000
1.7889	0.002830	0.001057	0.0000	0.0000
1.8278	0.002915	0.001103	0.0000	0.0000
1.8667	0.003001	0.001151	0.0000	0.0000
1.9056	0.003088	0.001200	0.0000	0.0000
1.9444	0.003177	0.001251	0.0000	0.0000
1.9833	0.003267	0.001303	0.0000	0.0000
2.0222	0.003358	0.001356	0.0000	0.0000
2.0611	0.003450	0.001411	0.0000	0.0000
2.1000	0.003544	0.001468	0.0000	0.0000
2.1389	0.003639	0.001526	0.0000	0.0000
2.1778	0.003735	0.001585	0.0000	0.0000
2.2167	0.003833	0.001646	0.0000	0.0000
2.2556	0.003931	0.001709	0.0000	0.0000
2.2944	0.004031	0.001773	0.0000	0.0000
2.3333	0.004132	0.001839	0.0000	0.0000
2.3722	0.004235	0.001906	0.0000	0.0000
2.4111	0.004338	0.001976	0.0000	0.0000
2.4500	0.004443	0.002046	0.0000	0.0000
2.4889	0.004549	0.002119	0.0000	0.0000

2.5278	0.004657	0.002298	0.0000	0.0000
2.5667	0.004765	0.002481	0.0000	0.0000
2.6056	0.004875	0.002669	0.0000	0.0000
2.6444	0.004986	0.002860	0.0000	0.0000
2.6833	0.005099	0.003057	0.0000	0.0000
2.7222	0.005212	0.003257	0.0000	0.0000
2.7611	0.005327	0.003462	0.0000	0.0000
2.8000	0.005444	0.003671	0.0000	0.0000
2.8389	0.005561	0.003885	0.0000	0.0000
2.8778	0.005680	0.004104	0.0000	0.0000
2.9167	0.005799	0.004327	0.0000	0.0000
2.9556	0.005921	0.004555	0.0000	0.0000
2.9944	0.006043	0.004788	0.0000	0.0000
3.0333	0.006167	0.005025	0.0000	0.0000
3.0722	0.006292	0.005267	0.0000	0.0000
3.1111	0.006418	0.005514	0.0000	0.0000
3.1500	0.006545	0.005767	0.0000	0.0000
3.1889	0.006674	0.006024	0.0000	0.0000
3.2278	0.006804	0.006286	0.0000	0.0000
3.2667	0.006935	0.006553	0.0000	0.0000
3.3056	0.007067	0.006825	0.0000	0.0000
3.3444	0.007201	0.007102	0.0000	0.0000
3.3833	0.007336	0.007385	0.0000	0.0000
3.4222	0.007472	0.007673	0.0000	0.0000
3.4611	0.007609	0.007966	0.0000	0.0000

**Surface retention 1 Hydraulic Table**

<u>Stage(feet)</u>	<u>Area(ac.)</u>	<u>Volume(ac-ft.)</u>	<u>Discharge(cfs)</u>	<u>To Amended(cfs)</u>	<u>Wetted Surface</u>
3.4611	0.000275	0.007966	0.0000	0.0000	0.0000
3.5000	0.007748	0.008265	0.0000	0.0000	0.0000
3.5389	0.007888	0.008569	0.0000	0.0000	0.0000
3.5000	0.013774	0.014095	0.0000	0.0056	0.0000

**Name** : Surface retention 1

**Element Flows To:**

**Outlet 1**                      **Outlet 2**  
 Bioretention 1

**ANALYSIS RESULTS**

**Stream Protection Duration**

**Predeveloped Landuse Totals for POC #1**

**Total Pervious Area:0**

**Total Impervious Area:0.0086**

**Mitigated Landuse Totals for POC #1**

**Total Pervious Area:0**

Total Impervious Area:0.0086

---

Flow Frequency Return Periods for Predeveloped. POC #1

<u>Return Period</u>	<u>Flow(cfs)</u>
2 year	0.003279
5 year	0.004142
10 year	0.004728
25 year	0.005488
50 year	0.00607
100 year	0.006666

Flow Frequency Return Periods for Mitigated. POC #1

<u>Return Period</u>	<u>Flow(cfs)</u>
2 year	0.001468
5 year	0.001843
10 year	0.002081
25 year	0.002374
50 year	0.002587
100 year	0.002798

---

Stream Protection Duration

Annual Peaks for Predeveloped and Mitigated. POC #1

<u>Year</u>	<u>Predeveloped</u>	<u>Mitigated</u>
1949	0.004	0.002
1950	0.005	0.001
1951	0.003	0.002
1952	0.002	0.001
1953	0.003	0.001
1954	0.003	0.001
1955	0.003	0.002
1956	0.003	0.002
1957	0.003	0.002
1958	0.003	0.001
1959	0.003	0.001
1960	0.003	0.002
1961	0.003	0.001
1962	0.003	0.001
1963	0.003	0.001
1964	0.003	0.001
1965	0.003	0.001
1966	0.002	0.001
1967	0.004	0.002
1968	0.005	0.001
1969	0.003	0.001
1970	0.003	0.001
1971	0.004	0.001
1972	0.004	0.002
1973	0.002	0.001
1974	0.003	0.001
1975	0.004	0.002
1976	0.003	0.001
1977	0.003	0.001
1978	0.003	0.002
1979	0.005	0.001
1980	0.004	0.002

1981	0.003	0.001
1982	0.005	0.002
1983	0.004	0.002
1984	0.002	0.001
1985	0.003	0.001
1986	0.003	0.002
1987	0.005	0.002
1988	0.003	0.001
1989	0.003	0.001
1990	0.006	0.002
1991	0.005	0.002
1992	0.002	0.001
1993	0.002	0.001
1994	0.002	0.001
1995	0.003	0.001
1996	0.003	0.002
1997	0.003	0.002
1998	0.003	0.001
1999	0.007	0.002
2000	0.003	0.001
2001	0.004	0.001
2002	0.004	0.002
2003	0.003	0.001
2004	0.006	0.003
2005	0.003	0.002
2006	0.002	0.001
2007	0.006	0.002
2008	0.005	0.002
2009	0.004	0.002

---

**Stream Protection Duration**

**Ranked Annual Peaks for Predeveloped and Mitigated. POC #1**

<b>Rank</b>	<b>Predeveloped</b>	<b>Mitigated</b>
1	0.0065	0.0027
2	0.0061	0.0025
3	0.0058	0.0022
4	0.0057	0.0022
5	0.0048	0.0022
6	0.0047	0.0022
7	0.0047	0.0021
8	0.0046	0.0021
9	0.0046	0.0020
10	0.0046	0.0020
11	0.0046	0.0020
12	0.0042	0.0019
13	0.0042	0.0019
14	0.0042	0.0019
15	0.0042	0.0018
16	0.0040	0.0018
17	0.0039	0.0018
18	0.0038	0.0018
19	0.0038	0.0018
20	0.0036	0.0017
21	0.0036	0.0017
22	0.0035	0.0017
23	0.0035	0.0016

24	0.0034	0.0015
25	0.0034	0.0015
26	0.0034	0.0015
27	0.0034	0.0015
28	0.0033	0.0015
29	0.0032	0.0015
30	0.0032	0.0015
31	0.0032	0.0014
32	0.0032	0.0014
33	0.0032	0.0014
34	0.0031	0.0014
35	0.0031	0.0014
36	0.0030	0.0014
37	0.0030	0.0013
38	0.0030	0.0013
39	0.0030	0.0013
40	0.0029	0.0013
41	0.0028	0.0013
42	0.0028	0.0012
43	0.0028	0.0012
44	0.0028	0.0012
45	0.0028	0.0012
46	0.0027	0.0012
47	0.0027	0.0012
48	0.0027	0.0012
49	0.0027	0.0012
50	0.0027	0.0012
51	0.0026	0.0012
52	0.0025	0.0012
53	0.0025	0.0012
54	0.0025	0.0011
55	0.0025	0.0011
56	0.0025	0.0011
57	0.0024	0.0011
58	0.0023	0.0010
59	0.0023	0.0009
60	0.0023	0.0009
61	0.0021	0.0008

---

**Stream Protection Duration**

**POC #1**

**The Facility PASSED**

**The Facility PASSED.**

<b>Flow(cfs)</b>	<b>Predev</b>	<b>Mit</b>	<b>Percentage</b>	<b>Pass/Fail</b>
0.0016	1804	1284	71	Pass
0.0017	1636	1099	67	Pass
0.0017	1472	973	66	Pass
0.0018	1345	853	63	Pass
0.0018	1227	696	56	Pass
0.0019	1102	562	50	Pass
0.0019	1002	465	46	Pass
0.0020	920	401	43	Pass
0.0020	853	340	39	Pass
0.0020	789	280	35	Pass

0.0021	725	227	31	Pass
0.0021	665	181	27	Pass
0.0022	610	139	22	Pass
0.0022	571	111	19	Pass
0.0023	532	91	17	Pass
0.0023	488	77	15	Pass
0.0024	451	63	13	Pass
0.0024	420	48	11	Pass
0.0024	389	40	10	Pass
0.0025	364	27	7	Pass
0.0025	339	22	6	Pass
0.0026	316	17	5	Pass
0.0026	295	11	3	Pass
0.0027	272	1	0	Pass
0.0027	256	0	0	Pass
0.0028	238	0	0	Pass
0.0028	221	0	0	Pass
0.0028	206	0	0	Pass
0.0029	193	0	0	Pass
0.0029	181	0	0	Pass
0.0030	171	0	0	Pass
0.0030	161	0	0	Pass
0.0031	148	0	0	Pass
0.0031	139	0	0	Pass
0.0032	135	0	0	Pass
0.0032	122	0	0	Pass
0.0033	113	0	0	Pass
0.0033	107	0	0	Pass
0.0033	105	0	0	Pass
0.0034	100	0	0	Pass
0.0034	92	0	0	Pass
0.0035	87	0	0	Pass
0.0035	84	0	0	Pass
0.0036	73	0	0	Pass
0.0036	71	0	0	Pass
0.0037	65	0	0	Pass
0.0037	63	0	0	Pass
0.0037	62	0	0	Pass
0.0038	58	0	0	Pass
0.0038	54	0	0	Pass
0.0039	54	0	0	Pass
0.0039	52	0	0	Pass
0.0040	50	0	0	Pass
0.0040	46	0	0	Pass
0.0041	45	0	0	Pass
0.0041	40	0	0	Pass
0.0041	38	0	0	Pass
0.0042	33	0	0	Pass
0.0042	32	0	0	Pass
0.0043	29	0	0	Pass
0.0043	28	0	0	Pass
0.0044	25	0	0	Pass
0.0044	22	0	0	Pass
0.0045	21	0	0	Pass
0.0045	20	0	0	Pass
0.0045	17	0	0	Pass
0.0046	13	0	0	Pass

0.0046	12	0	0	Pass
0.0047	9	0	0	Pass
0.0047	9	0	0	Pass
0.0048	9	0	0	Pass
0.0048	9	0	0	Pass
0.0049	8	0	0	Pass
0.0049	8	0	0	Pass
0.0050	8	0	0	Pass
0.0050	8	0	0	Pass
0.0050	8	0	0	Pass
0.0051	8	0	0	Pass
0.0051	8	0	0	Pass
0.0052	7	0	0	Pass
0.0052	7	0	0	Pass
0.0053	7	0	0	Pass
0.0053	7	0	0	Pass
0.0054	7	0	0	Pass
0.0054	7	0	0	Pass
0.0054	6	0	0	Pass
0.0055	6	0	0	Pass
0.0055	6	0	0	Pass
0.0056	6	0	0	Pass
0.0056	6	0	0	Pass
0.0057	6	0	0	Pass
0.0057	5	0	0	Pass
0.0058	5	0	0	Pass
0.0058	4	0	0	Pass
0.0058	3	0	0	Pass
0.0059	3	0	0	Pass
0.0059	2	0	0	Pass
0.0060	2	0	0	Pass
0.0060	2	0	0	Pass
0.0061	2	0	0	Pass

---



---

**LID Duration**

**LID Duration**

**Annual Peaks for Predeveloped and Mitigated. POC #1**

<b>Year</b>	<b>Predeveloped</b>	<b>Mitigated</b>
1949	0.004	0.002
1950	0.005	0.001
1951	0.003	0.002
1952	0.002	0.001
1953	0.003	0.001
1954	0.003	0.001
1955	0.003	0.002
1956	0.003	0.002
1957	0.003	0.002
1958	0.003	0.001
1959	0.003	0.001
1960	0.003	0.002
1961	0.003	0.001
1962	0.003	0.001

1963	0.003	0.001
1964	0.003	0.001
1965	0.003	0.001
1966	0.002	0.001
1967	0.004	0.002
1968	0.005	0.001
1969	0.003	0.001
1970	0.003	0.001
1971	0.004	0.001
1972	0.004	0.002
1973	0.002	0.001
1974	0.003	0.001
1975	0.004	0.002
1976	0.003	0.001
1977	0.003	0.001
1978	0.003	0.002
1979	0.005	0.001
1980	0.004	0.002
1981	0.003	0.001
1982	0.005	0.002
1983	0.004	0.002
1984	0.002	0.001
1985	0.003	0.001
1986	0.003	0.002
1987	0.005	0.002
1988	0.003	0.001
1989	0.003	0.001
1990	0.006	0.002
1991	0.005	0.002
1992	0.002	0.001
1993	0.002	0.001
1994	0.002	0.001
1995	0.003	0.001
1996	0.003	0.002
1997	0.003	0.002
1998	0.003	0.001
1999	0.007	0.002
2000	0.003	0.001
2001	0.004	0.001
2002	0.004	0.002
2003	0.003	0.001
2004	0.006	0.003
2005	0.003	0.002
2006	0.002	0.001
2007	0.006	0.002
2008	0.005	0.002
2009	0.004	0.002

---

**LID Duration**

**Ranked Annual Peaks for Predeveloped and Mitigated. POC #1**

<b>Rank</b>	<b>Predeveloped</b>	<b>Mitigated</b>
1	0.0065	0.0027
2	0.0061	0.0025
3	0.0058	0.0022
4	0.0057	0.0022
5	0.0048	0.0022

6	0.0047	0.0022
7	0.0047	0.0021
8	0.0046	0.0021
9	0.0046	0.0020
10	0.0046	0.0020
11	0.0046	0.0020
12	0.0042	0.0019
13	0.0042	0.0019
14	0.0042	0.0019
15	0.0042	0.0018
16	0.0040	0.0018
17	0.0039	0.0018
18	0.0038	0.0018
19	0.0038	0.0018
20	0.0036	0.0017
21	0.0036	0.0017
22	0.0035	0.0017
23	0.0035	0.0016
24	0.0034	0.0015
25	0.0034	0.0015
26	0.0034	0.0015
27	0.0034	0.0015
28	0.0033	0.0015
29	0.0032	0.0015
30	0.0032	0.0015
31	0.0032	0.0014
32	0.0032	0.0014
33	0.0032	0.0014
34	0.0031	0.0014
35	0.0031	0.0014
36	0.0030	0.0014
37	0.0030	0.0013
38	0.0030	0.0013
39	0.0030	0.0013
40	0.0029	0.0013
41	0.0028	0.0013
42	0.0028	0.0012
43	0.0028	0.0012
44	0.0028	0.0012
45	0.0028	0.0012
46	0.0027	0.0012
47	0.0027	0.0012
48	0.0027	0.0012
49	0.0027	0.0012
50	0.0027	0.0012
51	0.0026	0.0012
52	0.0025	0.0012
53	0.0025	0.0012
54	0.0025	0.0011
55	0.0025	0.0011
56	0.0025	0.0011
57	0.0024	0.0011
58	0.0023	0.0010
59	0.0023	0.0009
60	0.0023	0.0009
61	0.0021	0.0008

---

LID Duration

POC #1

The Facility PASSED

The Facility PASSED.

Flow(cfs)	Predev	Mit	Percentage	Pass/Fail
0.0016	1804	1284	71	Pass
0.0017	1636	1099	67	Pass
0.0017	1472	973	66	Pass
0.0018	1345	853	63	Pass
0.0018	1227	696	56	Pass
0.0019	1102	562	50	Pass
0.0019	1002	465	46	Pass
0.0020	920	401	43	Pass
0.0020	853	340	39	Pass
0.0020	789	280	35	Pass
0.0021	725	227	31	Pass
0.0021	665	181	27	Pass
0.0022	610	139	22	Pass
0.0022	571	111	19	Pass
0.0023	532	91	17	Pass
0.0023	488	77	15	Pass
0.0024	451	63	13	Pass
0.0024	420	48	11	Pass
0.0024	389	40	10	Pass
0.0025	364	27	7	Pass
0.0025	339	22	6	Pass
0.0026	316	17	5	Pass
0.0026	295	11	3	Pass
0.0027	272	1	0	Pass
0.0027	256	0	0	Pass
0.0028	238	0	0	Pass
0.0028	221	0	0	Pass
0.0028	206	0	0	Pass
0.0029	193	0	0	Pass
0.0029	181	0	0	Pass
0.0030	171	0	0	Pass
0.0030	161	0	0	Pass
0.0031	148	0	0	Pass
0.0031	139	0	0	Pass
0.0032	135	0	0	Pass
0.0032	122	0	0	Pass
0.0033	113	0	0	Pass
0.0033	107	0	0	Pass
0.0033	105	0	0	Pass
0.0034	100	0	0	Pass
0.0034	92	0	0	Pass
0.0035	87	0	0	Pass
0.0035	84	0	0	Pass
0.0036	73	0	0	Pass
0.0036	71	0	0	Pass
0.0037	65	0	0	Pass
0.0037	63	0	0	Pass
0.0037	62	0	0	Pass
0.0038	58	0	0	Pass

0.0038	54	0	0	Pass
0.0039	54	0	0	Pass
0.0039	52	0	0	Pass
0.0040	50	0	0	Pass
0.0040	46	0	0	Pass
0.0041	45	0	0	Pass
0.0041	40	0	0	Pass
0.0041	38	0	0	Pass
0.0042	33	0	0	Pass
0.0042	32	0	0	Pass
0.0043	29	0	0	Pass
0.0043	28	0	0	Pass
0.0044	25	0	0	Pass
0.0044	22	0	0	Pass
0.0045	21	0	0	Pass
0.0045	20	0	0	Pass
0.0045	17	0	0	Pass
0.0046	13	0	0	Pass
0.0046	12	0	0	Pass
0.0047	9	0	0	Pass
0.0047	9	0	0	Pass
0.0048	9	0	0	Pass
0.0048	9	0	0	Pass
0.0049	8	0	0	Pass
0.0049	8	0	0	Pass
0.0050	8	0	0	Pass
0.0050	8	0	0	Pass
0.0050	8	0	0	Pass
0.0051	8	0	0	Pass
0.0051	8	0	0	Pass
0.0052	7	0	0	Pass
0.0052	7	0	0	Pass
0.0053	7	0	0	Pass
0.0053	7	0	0	Pass
0.0054	7	0	0	Pass
0.0054	7	0	0	Pass
0.0054	6	0	0	Pass
0.0055	6	0	0	Pass
0.0055	6	0	0	Pass
0.0056	6	0	0	Pass
0.0056	6	0	0	Pass
0.0057	6	0	0	Pass
0.0057	5	0	0	Pass
0.0058	5	0	0	Pass
0.0058	4	0	0	Pass
0.0058	3	0	0	Pass
0.0059	3	0	0	Pass
0.0059	2	0	0	Pass
0.0060	2	0	0	Pass
0.0060	2	0	0	Pass
0.0061	2	0	0	Pass

---

Water Quality BMP Flow and Volume for POC #1  
On-line facility volume: 0 acre-feet  
On-line facility target flow: 0 cfs.

Adjusted for 15 min: 0 cfs.  
 Off-line facility target flow: 0 cfs.  
 Adjusted for 15 min: 0 cfs.

---

**LID Report**

LID Technique	Water Quality	Used for Percent Treatment? Water Quality	Total Volume Comment Needs Treatment (ac-ft)	Volume Through Facility (ac-ft)	Infiltration Volume (ac-ft.)	Cumulative Volume Infiltration Credit
retention	1 POC	Y	1.48	1.63	0.00	N
0.00	1.63	100.00	Treat. Credit			
Total Volume Infiltrated			1.48	1.63	0.00	0.00
1.63	2 / 2 = 100%	Treat. Credit = 100%				
Compliance with LID Standard 8						
Duration Analysis Result = Passed						

---

**PerlnD and ImplnD Changes**

No changes have been made.

---

This program and accompanying documentation are provided 'as-is' without warranty of any kind. The entire risk regarding the performance and results of this program is assumed by End User. Clear Creek Solutions Inc. and the governmental licensee or sublicensees disclaim all warranties, either expressed or implied, including but not limited to implied warranties of program and accompanying documentation. In no event shall Clear Creek Solutions Inc. be liable for any damages whatsoever (including without limitation to damages for loss of business profits, loss of business information, business interruption, and the like) arising out of the use of, or inability to use this program even if Clear Creek Solutions Inc. or their authorized representatives have been advised of the possibility of such damages. Software Copyright © by : Clear Creek Solutions, Inc. 2005-2025; All Rights Reserved.

May 2, 2016

JN 16095

Derek Lee Cheshire  
7615 East Mercer Way  
Mercer Island, Washington 98040

*via email: derek.cheshire@microsoft.com*

Subject: **Transmittal Letter – Geotechnical Engineering Study**  
Proposed Residence Addition and DADU  
7615 East Mercer Way  
Mercer Island, Washington

Dear Mr. Cheshire:

We are pleased to present this geotechnical engineering report for the addition to the existing single-family residence and the detached accessory dwelling unit (DADU) to be constructed in Mercer Island, Washington. The scope of our services consisted of exploring site surface and subsurface conditions, and then developing this report to provide recommendations for general earthwork and design criteria for foundations and retaining walls. This work was authorized by your acceptance of our proposal, P-9398, dated February 19, 2016.

The attached report contains a discussion of the study and our recommendations. Please contact us if there are any questions regarding this report, or for further assistance during the design and construction phases of this project.

Respectfully submitted,

GEOTECH CONSULTANTS, INC.



Thor Christensen, P.E.  
Senior Engineer

cc: **Russell Architecture** – Teresa Russell  
*via email: teresarussell@gmail.com*

TRC/DRW:mc

**GEOTECHNICAL ENGINEERING STUDY**  
**Proposed Residence Addition and DADU**  
**7615 East Mercer Way**  
**Mercer Island, Washington**

This report presents the findings and recommendations of our geotechnical engineering study for the site of the proposed residence addition and detached accessory dwelling unit (DADU) to be located in Mercer Island.

We were provided with a topographic survey prepared by GeoDimensions dated January 26, 2016. We were also provided with a site plan prepared by Russell Architecture dated March 9, 2016. Based on this information and conversations with the project architect, we understand that the development will consist of two different structures. One is an addition to the south side of the existing residence. The addition would have one-story and a basement that daylights toward the west, matching the residence. The basement will have a floor elevation of 143 feet, which will require an excavation of up to about 7 feet. The southeast corner of the addition will be set back 5 feet from the southern property line, but the remainder of the addition will have a greater setback.

The second structure would be a DADU will be constructed about 100 feet northeast of the residence. The lowest level of the DADU would be a garage whose door in on its southern, downslope side. The basement slab will have an elevation of 129 feet. An excavation of about 18 feet will be required at the northwest corner of the DADU, and the excavation depth reduces toward the southeast. The DADU will be set back 10 feet from the northern property line.

We also understand that a residence may someday be constructed in the eastern portion of the property, but that would not be a part of the current project.

If the scope of the project changes from what we have described above, we should be provided with revised plans in order to determine if modifications to the recommendations and conclusions of this report are warranted.

**SITE CONDITIONS**

***SURFACE***

The Vicinity Map, Plate 1, illustrates the general location of the trapezoid-shaped site in Mercer Island. The site is long in the east-west direction, with an average length of about 600 feet. It is bordered to the southeast by East Mercer Way and approximately the eastern 150 feet of the north property line is bordered by Southeast 76<sup>th</sup> Street, otherwise the property is surrounded by residences.

The terrain within the site generally slopes down toward the east. In the western 40 to 120 feet of the property, the ground has an inclination close to 2:1 (H:V), and then abruptly steepens to an inclination of 1:1 to 0.75:1. This steeper area has a height of 10 to 60 feet. The 100 feet of terrain east of this very steep slope has an inclination that starts close to 2:1 and flattens to about 3:1. The western slope is vegetated with trees and brush. A stream emerges from the base of the steep western slope and winds across the eastern portion of the site.

A bench about 100 feet wide is at the base of the western slope, near the center of the site. The western part of this bench is utilized as a yard and the existing residence is close to the southeast corner of this bench. The residence has one story and a basement that daylights toward the west. A tall, very-large-diameter redwood tree is located close to the southeast corner of the residence; it has a straight trunk and no bows or kinks that would indicate lateral movement. We did not observe cracks or indications of settlement-related distress in the residence foundations or the residence structure.

About 10 feet east of the residence the ground declines 20 vertical feet at an inclination of 1.5:1. Several mature evergreen trees grow on this slope, and exhibit mostly straight to only slightly bowed trunks. This indicates that the slope has been stable during the lifetime of the trees. This slope does not extend beyond the north edge of the residence, at that location it turns toward the east and flattens in inclination. One hundred and twenty feet east of the residence it has an inclination of 2:1 and 200 feet east of the residence it has an inclination of 3:1.

The north side of the central bench extends about 100 feet to the east of the residence footprint. Several mature evergreen trees grow in this northeastern part of the bench and most of those have severely bowed trunks and/or do not grow vertically, indicating recent soil movement. East of this northeast bench the ground slopes down toward the eastern corner of the property with an inclination close to 3:1. A gravel driveway accesses the site residence from Southeast 76<sup>th</sup> Street. The site stream passes below the driveway in a culvert.

There is a steep cut about 6 feet tall along the east edge of the site, and a ditch at the base of the cut. It is apparent that this cut was made for the adjacent East Mercer Way.

### ***Landslide History***

The property is located in an area that is known to have been affected by a large, ancient landslide that may have occurred soon after the last glaciers receded about 13,000 years ago. This ancient movement occurred as a large slump, resulting in a very steep headscarp that crosses the western part of the site. The majority of the soil that slumped during the landslide moved into what is now Lake Washington.

The Mercer Island Landslide Hazard Assessment map by Kathy Troost and Aaron Wischer dated April 2009 shows that the site has been designated as a Landslide Hazard Area. That map also shows that the site has a slope inclination of 15 percent or steeper, and that several landslides have been identified within and close to the site. Additionally, the Mercer Island Seismic Hazard Assessment map by Kathy Troost and Aaron Wischer dated April 2009 shows that the site has been designated as a Seismic Hazard Area. Both of these maps show that the site is underlain by landslide and mass wastage deposits.

### ***SUBSURFACE***

The subsurface conditions were explored by drilling five test borings at the approximate locations shown on the Site Exploration Plan, Plate 2. Our exploration program was based on the proposed construction, anticipated subsurface conditions and those encountered during exploration, and the scope of work outlined in our proposal.

The borings were drilled on March 31 and April 5, 2016 using a track-mounted, hollow-stem auger drill. Samples were taken at approximate 2.5 and 5-foot intervals with a standard penetration

sampler. This split-spoon sampler, which has a 2-inch outside diameter, is driven into the soil with a 140-pound hammer falling 30 inches. The number of blows required to advance the sampler a given distance is an indication of the soil density or consistency. A geotechnical engineer from our staff observed the drilling process, logged the test borings, and obtained representative samples of the soil encountered. The Test Boring Logs are attached as Plates 3 through 10.

### **Soil Conditions**

Test Borings 1 and 2 were located near the planned residence addition. Test Boring 2, at the south side of the addition footprint, revealed medium-dense silty sand at 2.5 feet. Below that material, and close to the ground surface at Test Boring 1 close to the top of the adjacent steep slope, the explorations encountered silt that was initially medium-stiff to stiff and became medium-dense or stiff at 5 to 7.5 feet. The silt was not disturbed and continued to the base of the borings at 11.5 and 26.5 feet.

The conditions near the proposed DADU were explored with Test Borings 3 and 4 and were significantly different from the soils revealed in the area of the proposed addition. The ground surface at Test Boring 3 was about 12 feet higher in elevation than Test Boring 4. The upper soil in Test Boring 3 was loose silty sand with gravel that had a thickness of about 9 feet. Below that material, and close to the surface at Test Boring 4, we observed 8 to 14 feet of medium-dense sand with gravel. In Test Boring 4 this was followed by about 5 feet of medium-dense silty sand with gravel. The sand with gravel and silty sand with gravel were underlain by silt that was medium-dense to medium-stiff and jumbled because of past slope movement (ancient landslide soil). The jumbled silt continued to 40.5 feet in Test Boring 3, and to about 33 feet in Test Boring 4. That silt contained an approximately 8-foot layer of wet sand with silt in Test Boring 4. The ancient landslide soil was underlain by layers of very stiff clayey silt and medium-dense sand with silt that extended to 41.5 and 51.5 feet.

Test Boring 5, located in the lower, eastern part of the property, was somewhat similar to Test Borings 3 and 4, with loose to medium-dense silty sand with gravel underlain by loose sand to about 23 feet. Below the sand, the test boring revealed medium-stiff, ancient landslide silt to a depth of about 29 feet. The next soil layer was intact silt that was loose to stiff at 30 feet, stiff from 35 to 40 feet, and very stiff at 45 feet.

### **Groundwater Conditions**

Groundwater seepage was observed at a depth of 7.5 and 10 feet in Test Borings 3 and 5. In Test Boring 4 we observed artesian water that rose to approximately 15 feet below the ground surface. The test borings were left open for only a short time period. Therefore, the seepage levels on the logs represent the location of transient water seepage and may not indicate the static groundwater level. Groundwater levels encountered during drilling can be deceptive, because seepage into the boring can be blocked or slowed by the auger itself. It should be noted that groundwater levels vary seasonally with rainfall and other factors and is generally highest during the normally wet winter and spring months.

The stratification lines on the logs represent the approximate boundaries between soil types at the exploration locations. The actual transition between soil types may be gradual, and subsurface conditions can vary between exploration locations. The logs provide specific subsurface information only at the locations tested. If a transition in soil type occurred between samples in the borings, the depth of the transition was interpreted. The relative densities and moisture descriptions indicated

on the test boring logs are interpretive descriptions based on the conditions observed during drilling.

## **SEISMIC CONSIDERATIONS**

In accordance with the International Building Code (IBC), the site class within 100 feet of the ground surface is best represented by Site Class Type D (Stiff Site Class). The site soils have a very low potential for seismic liquefaction because of their clayey or stiff nature, and/or the lack of saturated sandy soil.

As noted in the USGS website, the mapped spectral acceleration value for a 0.2 second ( $S_s$ ) and 1.0 second period ( $S_1$ ) equals 1.46g and 0.56g, respectively. The IBC states that a site-specific seismic study need not be performed provided that the peak ground acceleration be equal to  $S_{DS}/2.5$ , where  $S_{DS}$  is determined in ASCE 7. It is noted that  $S_{DS}$  is equal to  $2/3S_{MS}$ .  $S_{MS}$  equals  $F_a$  times  $S_s$ , where  $F_a$  is determined in Table 11.4-1. For our site,  $F_a = 1.0$ . The calculated peak ground acceleration that we utilized for the seismic-related parameters (earth pressures and seismic surcharges) of this report equals 0.39g.

## **CONCLUSIONS AND RECOMMENDATIONS**

### **GENERAL**

*THIS SECTION CONTAINS A SUMMARY OF OUR STUDY AND FINDINGS FOR THE PURPOSES OF A GENERAL OVERVIEW ONLY. MORE SPECIFIC RECOMMENDATIONS AND CONCLUSIONS ARE CONTAINED IN THE REMAINDER OF THIS REPORT. ANY PARTY RELYING ON THIS REPORT SHOULD READ THE ENTIRE DOCUMENT.*

The test borings conducted at the proposed residence addition location encountered medium-stiff to medium-dense native soil that increased in relative density with depth. We have not observed indications of recent slope movement at the proposed residence addition footprint; in fact the mature straight evergreen trees just east of the residence indicate no significant slope movement has occurred in at least the last 50 years. In addition, the subsurface soils in our two test borings there were not disturbed. Furthermore, the existing residence foundation does not exhibit distress due to settlement or slope movement. For these reasons, it is our opinion that the addition can be supported with conventional footing foundations that bear on the medium-dense/medium-stiff native soils.

The soils that underlie the proposed DADU are disturbed to depths of about 34 to 41 feet, and evergreen trees close to the DADU are bowed. We believe that the very near-surface soils in that area have recently experienced slow creep-type movement (evidenced by bowing trees, etc), and we also believe based on the test borings and geologic information that an ancient landslide has occurred in that area of the DADU to a depth of about 34 to 41 feet. Research has shown that the ancient landslide likely occurred approximately 1100 to 1200 years ago with a high magnitude. More typically, smaller earthquakes with less magnitude or a different location than the one that occurred 1100 to 1200 years ago are likely in the Puget Sound region (such as the ones that have occurred in 1949, 1965, and 2001). The seismic considerations noted earlier regarding the IBC address the smaller earthquakes, and our recommendations and conclusions regarding the construction of the garage is with respect to these considerations. As noted in the following paragraphs and other sections of this report, we recommend that the DADU be supported on piles

that embed into the competent soil below about 34 to 41 feet. The use of such piles will prevent catastrophic settlement or movement of the foundations, and the safety of the occupants should be protected. The intent is not to prevent any damage to the foundation or ensure continued function of the structure if movement of the ancient landslide soil were to again occur. Thus, we believe that the DADU will be "safe" if the recommendations in this report are followed as discussed in the statement of risk that is included later in this section of the report.

Conventional footings are not appropriate for the DADU because of the potential for movement of the very upper soils and possibly the ancient landslide soils, and because of the marginal bearing capability of the upper soils. Therefore, we recommend that the DADU be supported with driven pipe piles or drilled concrete piles that are embedded into competent soil below these soils. There is a need for excavation shoring to provide lateral support of the residence that includes the used of drilled concrete piles. The concrete piles could be used to not only provide lateral support as part of the shoring, but also provide vertical support. Driven steel piles that are embedded well into the competent lower soil could also be used for vertical support of the garage. Recommendations regarding shoring piles and driven steel piles (pipe piles) are provided in later sections of this report. Piles will likely need to extend 50 to 60 feet below the ground surface. Regardless of which pile system is used, all piles should be connected via concrete grade beams, would maintain rigidity of the structure's foundation.

The site stream is located about 60 feet west of the DADU footprint, the lowest floor of that structure will be 10 feet below the elevation of the nearby part of the stream, and groundwater was encountered in the western DADU exploration (Test Boring 3) well above the base of the excavation. It appears that dewatering will be needed during construction to reduce the amount of water that enters the excavation.

The relatively shallow groundwater level creates several issues for both temporary and permanent conditions at the DADU. Well-constructed drainage and waterproofing will be important beneath and around the planned building. In addition to waterproofing and drainage measures placed against foundation walls, we recommend installing underslab drainage and a vapor barrier below the basement slab to reduce the potential for moisture to rise into finished living spaces. A typical underslab drainage detail is presented as Plate 13.

In order to satisfy the City of Mercer Island's requirements regarding geologic hazard areas, a statement of risk is needed. As such, we make the following statement:

In our judgment, provided the recommendations in this study are followed, the development will be designed so that the risk to the lot and adjacent properties is mitigated such that the site is determined to be safe.

If the site driveway is to be widened it should be toward the north, where the ground surface is generally higher than the driveway. The ground south of the driveway should not be raised by fill placement; that would decrease stability of slope and could contribute to slope failures.

We understand that potentially a new residence may be constructed on the lower reaches of the property in the future. Such a residence would be subject to the same recommendations of the proposed DADU because similar soils were encountered in the lower reaches of the site as the area of the DADU.

The erosion control measures needed during the site development will depend heavily on the weather conditions that are encountered. We anticipate that a silt fence will be needed around the

downslope sides of any cleared areas. Existing pavements, ground cover, and landscaping should be left in place wherever possible to minimize the amount of exposed soil. Rocked staging areas and construction access roads should be provided to reduce the amount of soil or mud carried off the property by trucks and equipment. Wherever possible, the access roads should follow the alignment of planned pavements. Trucks should not be allowed to drive off of the rock-covered areas. Cut slopes and soil stockpiles should be covered with plastic during wet weather. Following clearing or rough grading, it may be necessary to mulch or hydroseed bare areas that will not be immediately covered with landscaping or an impervious surface. On most construction projects, it is necessary to periodically maintain or modify temporary erosion control measures to address specific site and weather conditions.

The drainage and/or waterproofing recommendations presented in this report are intended only to prevent active seepage from flowing through concrete walls or slabs. Even in the absence of active seepage into and beneath structures, water vapor can migrate through walls, slabs, and floors from the surrounding soil, and can even be transmitted from slabs and foundation walls due to the concrete curing process. Water vapor also results from occupant uses, such as cooking and bathing. Excessive water vapor trapped within structures can result in a variety of undesirable conditions, including, but not limited to, moisture problems with flooring systems, excessively moist air within occupied areas, and the growth of molds, fungi, and other biological organisms that may be harmful to the health of the occupants. The designer or architect must consider the potential vapor sources and likely occupant uses, and provide sufficient ventilation, either passive or mechanical, to prevent a build up of excessive water vapor within the planned structure.

Geotech Consultants, Inc. should be allowed to review the final development plans to verify that the recommendations presented in this report are adequately addressed in the design. Such a plan review would be additional work beyond the current scope of work for this study, and it may include revisions to our recommendations to accommodate site, development, and geotechnical constraints that become more evident during the review process.

We recommend including this report, in its entirety, in the project contract documents. This report should also be provided to any future property owners so they will be aware of our findings and recommendations.

### **CONVENTIONAL FOUNDATIONS FOR THE RESIDENCE ADDITION**

The proposed residence addition can be supported on conventional continuous and spread footings bearing on undisturbed, medium-dense native soil. We recommend that continuous and individual spread footings have minimum widths of 16 and 24 inches, respectively. Exterior footings should also be bottomed at least 18 inches below the lowest adjacent finish ground surface for protection against frost and erosion. The local building codes should be reviewed to determine if different footing widths or embedment depths are required. Footing subgrades must be cleaned of loose or disturbed soil prior to pouring concrete. Depending upon site and equipment constraints, this may require removing the disturbed soil by hand.

An allowable bearing pressure of 2,000 pounds per square foot (psf) is appropriate for footings supported on competent native soil. A one-third increase in this design bearing pressure may be used when considering short-term wind or seismic loads. For the above design criteria, it is anticipated that the total post-construction settlement of footings founded on competent native soil will be about one-inch, with differential settlements on the order of one-half-inch in a distance of 30 feet along a continuous footing with a uniform load.

Lateral loads due to wind or seismic forces may be resisted by friction between the foundation and the bearing soil, or by passive earth pressure acting on the vertical, embedded portions of the foundation. For the latter condition, the foundation must be either poured directly against relatively level, undisturbed soil or be surrounded by level, well-compacted fill. We recommend using the following ultimate values for the foundation's resistance to lateral loading:

PARAMETER	ULTIMATE VALUE
Coefficient of Friction	0.40
Passive Earth Pressure	300 pcf

Where: pcf is Pounds per Cubic Foot, and Passive Earth Pressure is computed using the Equivalent Fluid Density.

If the ground in front of a foundation is loose or sloping, the passive earth pressure given above will not be appropriate. We recommend maintaining a safety factor of at least 1.5 for the foundation's resistance to lateral loading, when using the above ultimate values.

### **SHORING AND DRILLED CONCRETE PILES**

We have just considered a cantilevered soldier pile shoring system for this project because it has proven to be an efficient and economical method for providing excavation shoring where the depth of excavation is less than about 18 feet. For temporary shoring, it is common to include a safety factor of 1.2 in the design. If tie-back anchors are needed, we could provide information for those at a later date.

#### ***Soldier Pile Installation***

Soldier pile walls would be constructed after making planned cut slopes, and prior to commencing the mass excavation, by setting steel H-beams in a drilled hole and grouting the space between the beam and the soil with concrete for the entire height of the drilled hole. Normally, the drilling method for shoring is to constructed and "open hole". Because wet sand was encountered in our test borings near the DADU, the contractor should be prepared to case open holes or use the slurry method due to the strong likelihood of caving of the drilled hole. Alternatively, an augercast method of drilled piles could be used. Excessive ground loss in the drilled holes must be avoided to reduce the potential for settlement on adjacent properties. If water is present in a hole at the time the soldier pile is poured, concrete must be tremied to the bottom of the hole.

As excavation proceeds downward, the space between the piles should be lagged with timber, and any voids behind the timbers should be filled with pea gravel, or a slurry comprised of sand and fly ash. Treated lagging is usually required for permanent walls, while untreated lagging can often be utilized for temporary shoring walls. Temporary vertical cuts will be necessary between the soldier piles for the lagging placement. The prompt and careful installation of lagging is important, particularly in loose or caving soil, to maintain the integrity of the excavation and provide safer working conditions. Additionally, care must be taken by the excavator to remove no more soil between the soldier piles than is necessary to install the lagging. Caving or overexcavation during lagging placement could result in loss of ground on neighboring properties. Timber lagging should be designed for an

applied lateral pressure of 30 percent of the design wall pressure, if the pile spacing is less than three pile diameters. For larger pile spacings, the lagging should be designed for 50 percent of the design load.

### ***Soldier Pile Wall Design***

Temporary soldier pile shoring that is cantilevered and that has a level backslope, should be designed for an active soil pressure equal to that pressure exerted by an equivalent fluid with a unit weight of 35 pounds per cubic foot (pcf). An extra 5 pcf should be added if the shoring is permanent.

Traffic surcharges can typically be accounted for by increasing the effective height of the shoring wall by 2 feet. Slopes above the shoring walls will exert additional surcharge pressures. These surcharge pressures will vary, depending on the configuration of the cut slope and shoring wall. We can provide recommendations regarding slope surcharge pressures when the preliminary shoring design is completed.

It is important that the shoring design provides sufficient working room to drill and install the soldier piles, without needing to make unsafe, excessively steep temporary cuts. Cut slopes should be planned to intersect the backside of the drilled holes, not the back of the lagging.

Lateral movement of the soldier piles below the excavation level will be resisted by an ultimate passive soil pressure equal to that pressure exerted by a fluid with a density of 300 pcf. This soil pressure is valid only for a level excavation in front of the soldier pile; it acts on two times the grouted pile diameter. Cut slopes made in front of shoring walls significantly decrease the passive resistance. This includes temporary cuts necessary to install internal braces or rakers. The minimum embedment below the floor of the excavation for cantilever soldier piles should be equal to the height of the "stick-up."

The vertical capacity of soldier piles to carry the downward component of the tieback forces will be developed by a combination of frictional shaft resistance along the embedded length and pile end-bearing. The embedded length is only considered in the competent, non-landslide soil that is approximately 40 feet below the ground surface.

PARAMETER	DESIGN
Pile Shaft Friction	1,000 psf
Pile End-Bearing	10,000 psf

Where: psf is Pounds per Square Foot.

The above values assume that the excavation is level in front of the soldier pile and that the bottom of the pile is embedded a minimum of 10 feet below the floor of the excavation. For the pile end-bearing to be appropriate, the bottom of the drilled holes must be cleaned of loosened soil. The shoring contractor should be made aware of this, as it may affect their installation procedures. The concrete surrounding the embedded portion of the pile must have sufficient bond and strength to transfer the vertical load from the steel section through the concrete into the soil.

## **PIPE PILES**

Six-inch-diameter pipe piles driven with a 650- or 800- or 1,100-pound hydraulic jackhammer to the following final penetration rates may be assigned the following compressive capacities.

<b>INSIDE PILE DIAMETER</b>	<b>FINAL DRIVING RATE (1,100-pound hammer)</b>	<b>FINAL DRIVING RATE (2,700-pound hammer)</b>	<b>FINAL DRIVING RATE (3,000-pound hammer)</b>	<b>ALLOWABLE COMPRESSIVE CAPACITY</b>
6 inches	20 sec/inch	10 sec/inch	6 sec/inch	15 tons

**Note:** The refusal criteria indicated in the above table are valid only for pipe piles that are installed using a hydraulic impact hammer carried on leads that allow the hammer to sit on the top of the pile during driving. If the piles are installed by alternative methods, such as a vibratory hammer or a hammer that is hard-mounted to the installation machine, numerous load tests to 200 percent of the design capacity would be necessary to substantiate the allowable pile load. The appropriate number of load tests would need to be determined at the time the contractor and installation method are chosen.

As a minimum, Schedule 40 pipe should be used. The site soils are not highly organic, and are not located near salt water. As a result, they do not have an elevated corrosion potential. Considering this, it is our opinion that standard "black" pipe can be used, and corrosion protection, such as galvanizing, is not necessary for the pipe piles.

Pile caps and grade beams should be used to transmit loads to the piles. Isolated pile caps should include a minimum of two piles to reduce the potential for eccentric loads being applied to the piles. Subsequent sections of pipe can be connected with slip or threaded couplers, or they can be welded together. If slip couplers are used, they should fit snugly into the pipe sections. This may require that shims be used or that beads of welding flux be applied to the outside of the coupler.

Lateral loads due to wind or seismic forces may be resisted by passive earth pressure acting on the vertical, embedded portions of the foundation. For this condition, the foundation must be either poured directly against relatively level, undisturbed soil or be surrounded by level compacted fill. We recommend using a passive earth pressure of 250 pounds per cubic foot (pcf) for this resistance. If the ground in front of a foundation is loose or sloping, the passive earth pressure given above will not be appropriate. We recommend a safety factor of at least 1.5 for the foundation's resistance to lateral loading, when using the above ultimate passive value.

If lateral resistance from fill placed against the foundations is required for this project, the structural engineer should indicate this requirement on the plans for the general and earthwork contractor's information. Compacted fill placed against the foundations can consist of imported soil that is tamped into place using the backhoe or is compacted using a jumping jack compactor. It is necessary for the fill to be compacted to a firm condition, but it does not need to reach even 90 percent relative compaction to develop the passive resistance recommended above. Due to their small diameter, the lateral capacity of vertical pipe piles is relatively small. However, if lateral resistance in addition to passive soil resistance is required, we recommend driving battered piles in the same direction as the applied lateral load. The lateral capacity of a battered pile is equal to one-half of the lateral component of the allowable compressive load, with a maximum allowable lateral capacity of 1,000 pounds. The allowable vertical capacity of battered piles does not need to be reduced if the piles are battered steeper than 1:5 (Horizontal: Vertical).

## **FOUNDATION AND RETAINING WALLS**

Retaining walls backfilled on only one side should be designed to resist the lateral earth pressures imposed by the soil they retain. The following recommended parameters are for walls that restrain level backfill:

<b>PARAMETER</b>	<b>VALUE</b>
Active Earth Pressure *	40 pcf
Passive Earth Pressure	300 pcf
Coefficient of Friction**	0.35
Soil Unit Weight	130 pcf

Where: pcf is Pounds per Cubic Foot, and Active and Passive Earth Pressures are computed using the Equivalent Fluid Pressures.

\* For a restrained wall that cannot deflect at least 0.002 times its height, a uniform lateral pressure equal to 10 psf times the height of the wall should be added to the above active equivalent fluid pressure.

\*\* This is only suitable for the addition where footings can be used.

The design values given above do not include the effects of any hydrostatic pressures behind the walls and assume that no surcharges, such as those caused by slopes, vehicles, or adjacent foundations will be exerted on the walls. If these conditions exist, those pressures should be added to the above lateral soil pressures. Where sloping backfill is desired behind the walls, we will need to be given the wall dimensions and the slope of the backfill in order to provide the appropriate design earth pressures. The surcharge due to traffic loads behind a wall can typically be accounted for by adding a uniform pressure equal to 2 feet multiplied by the above active fluid density. Heavy construction equipment should not be operated behind retaining and foundation walls within a distance equal to the height of a wall, unless the walls are designed for the additional lateral pressures resulting from the equipment.

The values given above are to be used to design only permanent foundation and retaining walls that are to be backfilled, such as conventional walls constructed of reinforced concrete or masonry. It is not appropriate to use the above earth pressures and soil unit weight to back-calculate soil strength parameters for design of other types of retaining walls, such as soldier pile, reinforced earth, modular or soil nail walls. We can assist with design of these types of walls, if desired. The passive pressure given is appropriate only for a shear key poured directly against undisturbed native soil, or for the depth of level, well-compacted fill placed in front of a retaining or foundation wall. The values for friction and passive resistance are ultimate values and do not include a safety factor. No frictional resistance should be used for pile-supported structures. Restrained wall soil parameters should be utilized for a distance of 1.5 times the wall height from corners or bends in the walls. This is intended to reduce the amount of cracking that can occur where a wall is restrained by a corner.

### **Wall Pressures Due to Seismic Forces**

The surcharge wall loads that could be imposed by the design earthquake can be modeled by adding a uniform lateral pressure to the above-recommended active pressure. The recommended surcharge pressure is  $9H$  pounds per square foot (psf), where  $H$  is the design retention height of the wall. Using this increased pressure, the safety factor against sliding and overturning can be reduced to 1.2 for the seismic analysis.

### **Retaining Wall Backfill and Waterproofing**

Backfill placed behind retaining or foundation walls should be coarse, free-draining structural fill containing no organics. This backfill should contain no more than 5 percent silt or clay particles and have no gravel greater than 4 inches in diameter. The percentage of particles passing the No. 4 sieve should be between 25 and 70 percent.

The purpose of these backfill requirements is to ensure that the design criteria for a retaining wall are not exceeded because of a build-up of hydrostatic pressure behind the wall. Also, subsurface drainage systems are not intended to handle large volumes of water from surface runoff. The top 12 to 18 inches of the backfill should consist of a compacted, relatively impermeable soil or topsoil, or the surface should be paved. The ground surface must also slope away from backfilled walls to reduce the potential for surface water to percolate into the backfill. Water percolating through pervious surfaces (pavers, gravel, permeable pavement, etc.) must also be prevented from flowing toward walls or into the backfill zone. The compacted subgrade below pervious surfaces and any associated drainage layer should therefore be sloped away. Alternatively, a membrane and subsurface collection system could be provided below a pervious surface.

It is critical that the wall backfill be placed in lifts and be properly compacted, in order for the above-recommended design earth pressures to be appropriate. The wall design criteria assume that the backfill will be well-compacted in lifts no thicker than 12 inches. The compaction of backfill near the walls should be accomplished with hand-operated equipment to prevent the walls from being overloaded by the higher soil forces that occur during compaction. The section entitled ***General Earthwork and Structural Fill*** contains additional recommendations regarding the placement and compaction of structural fill behind retaining and foundation walls.

The above recommendations are not intended to waterproof below-grade walls, or to prevent the formation of mold, mildew or fungi in interior spaces. Over time, the performance of subsurface drainage systems can degrade, subsurface groundwater flow patterns can change, and utilities can break or develop leaks. Therefore, waterproofing should be provided where future seepage through the walls is not acceptable. This typically includes limiting cold-joints and wall penetrations, and using bentonite panels or membranes on the outside of the walls. There are a variety of different waterproofing materials and systems, which should be installed by an experienced contractor familiar with the anticipated construction and subsurface conditions. Applying a thin coat of asphalt emulsion to the outside face of a wall is not considered waterproofing, and will only help to reduce moisture generated from water vapor or capillary action from seeping through the concrete. As with any project, adequate ventilation of basement and crawl space areas is important to prevent a build up of water vapor that is commonly transmitted through concrete walls from the surrounding soil, even when seepage is not present. This is appropriate even when waterproofing is applied to the outside of foundation and retaining

walls. We recommend that you contact an experienced envelope consultant if detailed recommendations or specifications related to waterproofing design, or minimizing the potential for infestations of mold and mildew are desired.

The **General**, **Slabs-On-Grade**, and **Drainage Considerations** sections should be reviewed for additional recommendations related to the control of groundwater and excess water vapor for the anticipated construction.

## **SLABS-ON-GRADE**

The building floors of the addition can be constructed as slabs-on-grade atop competent native soil, or on structural fill. However, a slab-on-grade for the garage needs to be on at least 12 inches of imported material needed for an underslab drain as described in the **Drainage Considerations** section of this report. The subgrade soil must be in a firm, non-yielding condition at the time of slab construction or underslab fill placement. Any soft areas encountered should be excavated and replaced with select, imported structural fill.

Even where the exposed soils appear dry, water vapor will tend to naturally migrate upward through the soil to the new constructed space above it. This can affect moisture-sensitive flooring, cause imperfections or damage to the slab, or simply allow excessive water vapor into the space above the slab. All interior slabs-on-grade should be underlain by a capillary break drainage layer consisting of a minimum 4-inch thickness of clean gravel or crushed rock that has a fines content (percent passing the No. 200 sieve) of less than 3 percent and a sand content (percent passing the No. 4 sieve) of no more than 10 percent. Pea gravel or crushed rock are typically used for this layer. This capillary break/drainage layer is not necessary if an underslab drainage system is installed.

As noted by the American Concrete Institute (ACI) in the *Guides for Concrete Floor and Slab Structures*, proper moisture protection is desirable immediately below any on-grade slab that will be covered by tile, wood, carpet, impermeable floor coverings, or any moisture-sensitive equipment or products. ACI also notes that vapor *retarders* such as 6-mil plastic sheeting have been used in the past, but are now recommending a minimum 10-mil thickness for better durability and long term performance. A vapor retarder is defined as a material with a permeance of less than 0.3 perms, as determined by ASTM E 96. It is possible that concrete admixtures may meet this specification, although the manufacturers of the admixtures should be consulted. Where vapor retarders are used under slabs, their edges should overlap by at least 6 inches and be sealed with adhesive tape. The sheeting should extend to the foundation walls for maximum vapor protection. If no potential for vapor passage through the slab is desired, a vapor *barrier* should be used. A vapor barrier, as defined by ACI, is a product with a water transmission rate of 0.01 perms when tested in accordance with ASTM E 96. Reinforced membranes having sealed overlaps can meet this requirement.

The **General**, **Permanent Foundation and Retaining Walls**, and **Drainage Considerations** sections should be reviewed for additional recommendations related to the control of groundwater and excess water vapor for the anticipated construction.

## **EXCAVATIONS AND SLOPES**

Excavation slopes should not exceed the limits specified in local, state, and national government safety regulations. Temporary cuts to a depth of about 4 feet may be attempted vertically in unsaturated soil, if there are no indications of slope instability. However, vertical cuts should not be made near property boundaries, or existing utilities and structures. Based upon Washington Administrative Code (WAC) 296, Part N, the soil in the area of the residence addition would generally be classified as a Type B. Therefore, temporary cut slopes greater than 4 feet in height should not be excavated steeper than 1:1 (H:V). However, the soils revealed in Test Borings 3, 4, and 5 would generally be classified as Type C. Therefore, temporary cut slopes greater than 4 feet in height should not be excavated at an inclination steeper than 1.5:1 (Horizontal: Vertical), extending continuously between the top and the bottom of a cut.

The above-recommended temporary slope inclination is based on the conditions exposed in our explorations, and on what has been successful at other sites with similar soil conditions. It is possible that variations in soil and groundwater conditions will require modifications to the inclination at which temporary slopes can stand. Temporary cuts are those that will remain unsupported for a relatively short duration to allow for the construction of foundations, retaining walls, or utilities. Temporary cut slopes should be protected with plastic sheeting during wet weather. It is also important that surface runoff be directed away from the top of temporary slope cuts. Cut slopes should also be backfilled or retained as soon as possible to reduce the potential for instability. Please note that sand or loose soil can cave suddenly and without warning. Excavation, foundation, and utility contractors should be made especially aware of this potential danger. These recommendations may need to be modified if the area near the potential cuts has been disturbed in the past by utility installation, or if settlement-sensitive utilities are located nearby.

All permanent cuts into native soil should be inclined no steeper than 2.5:1 (H:V). Flatter inclinations would be necessary where soil is loose and wet. Water should not be allowed to flow uncontrolled over the top of any temporary or permanent slope. All permanently exposed slopes should be seeded with an appropriate species of vegetation to reduce erosion and improve the stability of the surficial layer of soil.

Any disturbance to the existing slope outside of the building limits may reduce the stability of the slope. Damage to the existing vegetation and ground should be minimized, and any disturbed areas should be revegetated as soon as possible. Soil from the excavation should not be placed on the slope, and this may require the off-site disposal of any surplus soil.

## **DRAINAGE CONSIDERATIONS**

If permanent foundation walls are constructed against the shoring walls, a plastic-backed drainage composite, such as Miradrain, Battledrain, or similar, should be placed against the entire surface of the shoring prior to pouring the foundation wall. Weep pipes located no more than 6 feet on-center should be connected to the drainage composite and poured into the foundation walls or the perimeter footing. A footing drain installed along the inside of the perimeter footing will be used to collect and carry the water discharged by the weep pipes to the storm system. Isolated zones of moisture or seepage can still reach the permanent wall where groundwater finds leaks or joints in the drainage composite. This is often an acceptable risk in unoccupied below-grade spaces, such as parking garages. However, formal waterproofing is typically necessary in areas where wet conditions at the face of the permanent wall will not be tolerable. If this is a concern, the permanent

drainage and waterproofing system should be designed by a specialty consultant familiar with the expected subsurface conditions and proposed construction.

Footing drains placed inside the building or behind backfilled walls should consist of 4-inch, perforated PVC pipe surrounded by at least 6 inches of 1-inch-minus, washed rock wrapped in a non-woven, geotextile filter fabric (Mirafi 140N, Supac 4NP, or similar material). At its highest point, a perforated pipe invert should be at least 6 inches below the level of a crawl space or the bottom of a floor slab, and it should be sloped slightly for drainage. Plate 11 presents typical considerations for footing drains and Plate 12 presents a typical shoring drain detail. All roof and surface water drains must be kept separate from the foundation drain system.

As noted in the **General** section of this report, underslab drainage should also be provided for the proposed DADU. Plate 13 provides several recommendations for the underslab drainage system.

As a minimum, a vapor retarder, as defined in the **Slabs-On-Grade** section, should be provided in any crawl space area to limit the transmission of water vapor from the underlying soils. Crawl space grades are sometimes left near the elevation of the bottom of the footings. As a result, an outlet drain is recommended for all crawl spaces to prevent an accumulation of any water that may bypass the footing drains. Providing even a few inches of free draining gravel underneath the vapor retarder limits the potential for seepage to build up on top of the vapor retarder.

Groundwater was observed during our field work. If seepage is encountered in an excavation, it should be drained from the site by directing it through drainage ditches, perforated pipe, or French drains, or by pumping it from sumps interconnected by shallow connector trenches at the bottom of the excavation.

The excavation and site should be graded so that surface water is directed off the site and away from the tops of slopes. Water should not be allowed to stand in any area where foundations, slabs, or pavements are to be constructed. Final site grading in areas adjacent to a building should slope away at least 2 percent, except where the area is paved. Surface drains should be provided where necessary to prevent ponding of water behind foundation or retaining walls. A discussion of grading and drainage related to pervious surfaces near walls and structures is contained in the **Foundation and Retaining Walls** section. Water from roof, storm water, and foundation drains should not be discharged onto slopes; it should be tightlined to a suitable outfall located away from any slopes.

## **GENERAL EARTHWORK AND STRUCTURAL FILL**

All building and pavement areas should be stripped of surface vegetation, topsoil, organic soil, and other deleterious material. The stripped or removed materials should not be mixed with any materials to be used as structural fill, but they could be used in non-structural areas, such as landscape beds.

Structural fill is defined as any fill, including utility backfill, placed under, or close to, a building, behind permanent retaining or foundation walls, or in other areas where the underlying soil needs to support loads. All structural fill should be placed in horizontal lifts with a moisture content at, or near, the optimum moisture content. The optimum moisture content is that moisture content that results in the greatest compacted dry density. The moisture content of fill is very important and must be closely controlled during the filling and compaction process.

The allowable thickness of the fill lift will depend on the material type selected, the compaction equipment used, and the number of passes made to compact the lift. The loose lift thickness should not exceed 12 inches. We recommend testing the fill as it is placed. If the fill is not sufficiently compacted, it can be recompacted before another lift is placed. This eliminates the need to remove the fill to achieve the required compaction. The following table presents recommended relative compactions for structural fill:

<b>LOCATION OF FILL PLACEMENT</b>	<b>MINIMUM RELATIVE COMPACTION</b>
Beneath slabs or walkways	95%
Filled slopes and behind retaining walls	90%
Beneath pavements	95% for upper 12 inches of subgrade; 90% below that level

Where: Minimum Relative Compaction is the ratio, expressed in percentages, of the compacted dry density to the maximum dry density, as determined in accordance with ASTM Test Designation D 1557-91 (Modified Proctor).

Onsite soils are not suitable for use as structural fill for this project. Structural fill that will be placed in wet weather should consist of a coarse, granular soil with a silt or clay content of no more than 5 percent. The percentage of particles passing the No. 200 sieve should be measured from that portion of soil passing the three-quarter-inch sieve.

### **LIMITATIONS**

The conclusions and recommendations contained in this report are based on site conditions as they existed at the time of our exploration and assume that the soil and groundwater conditions encountered in the test borings are representative of subsurface conditions on the site. If the subsurface conditions encountered during construction are significantly different from those observed in our explorations, we should be advised at once so that we can review these conditions and reconsider our recommendations where necessary. Unanticipated conditions are commonly encountered on construction sites and cannot be fully anticipated by merely taking samples in test borings. Subsurface conditions can also vary between exploration locations. Such unexpected conditions frequently require making additional expenditures to attain a properly constructed project. It is recommended that the owner consider providing a contingency fund to accommodate such potential extra costs and risks. This is a standard recommendation for all projects.

The recommendations presented in this report are directed toward the protection of only the proposed structures from damage due to slope movement. Predicting the future behavior of steep slopes and the potential effects of development on their stability is an inexact and imperfect science that is currently based mostly on the past behavior of slopes with similar characteristics. Landslides and soil movement can occur on steep slopes before, during, or after the development of property. At additional cost, we can provide recommendations for reducing the risk of future movement on the steep slopes, which could involve regrading the slopes or installing subsurface drains or costly retaining structures. The owner of any property containing, or located close to

steep slopes must ultimately accept the possibility that some slope movement could occur, resulting in possible loss of ground or damage to the facilities around the proposed building .

This report has been prepared for the exclusive use of Derek Lee Cheshire and his representatives for specific application to this project and site. Our conclusions and recommendations are professional opinions derived in accordance with our understanding of current local standards of practice, and within the scope of our services. No warranty is expressed or implied. The scope of our services does not include services related to construction safety precautions, and our recommendations are not intended to direct the contractor's methods, techniques, sequences, or procedures, except as specifically described in our report for consideration in design. Our services also do not include assessing or minimizing the potential for biological hazards, such as mold, bacteria, mildew and fungi in either the existing or proposed site development.

### **ADDITIONAL SERVICES**

Geotech Consultants, Inc. should be retained to provide geotechnical consultation, testing, and observation services during construction. This is to confirm that subsurface conditions are consistent with those indicated by our exploration, to evaluate whether earthwork and foundation construction activities comply with the general intent of the recommendations presented in this report, and to provide suggestions for design changes in the event subsurface conditions differ from those anticipated prior to the start of construction. However, our work would not include the supervision or direction of the actual work of the contractor and its employees or agents. Also, job and site safety, and dimensional measurements, will be the responsibility of the contractor.

During the construction phase, we will provide geotechnical observation and testing services when requested by you or your representatives. Please be aware that we can only document site work we actually observe. It is still the responsibility of your contractor or on-site construction team to verify that our recommendations are being followed, whether we are present at the site or not.

The following plates are attached to complete this report:

Plate 1	Vicinity Map
Plate 2	Site Exploration Plan
Plates 3 - 10	Test Boring Logs
Plate 11	Typical Footing Drain Detail
Plate 12	Typical Shoring Drain Detail
Plate 13	Typical Underslab Drainage Detail

We appreciate the opportunity to be of service on this project. Please contact us if you have any questions, or if we can be of further assistance.

Respectfully submitted,

GEOTECH CONSULTANTS, INC.



Thor Christensen, P.E.  
Senior Engineer

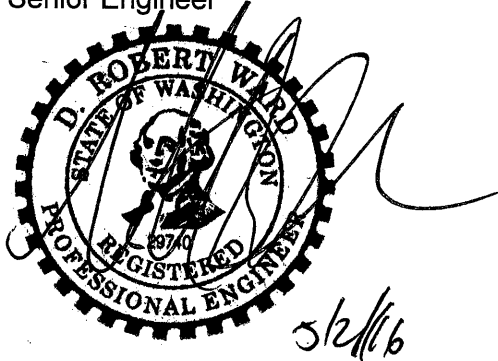

D. Robert Ward, P.E.  
Principal

TRC/DRW:mc



**NORTH**

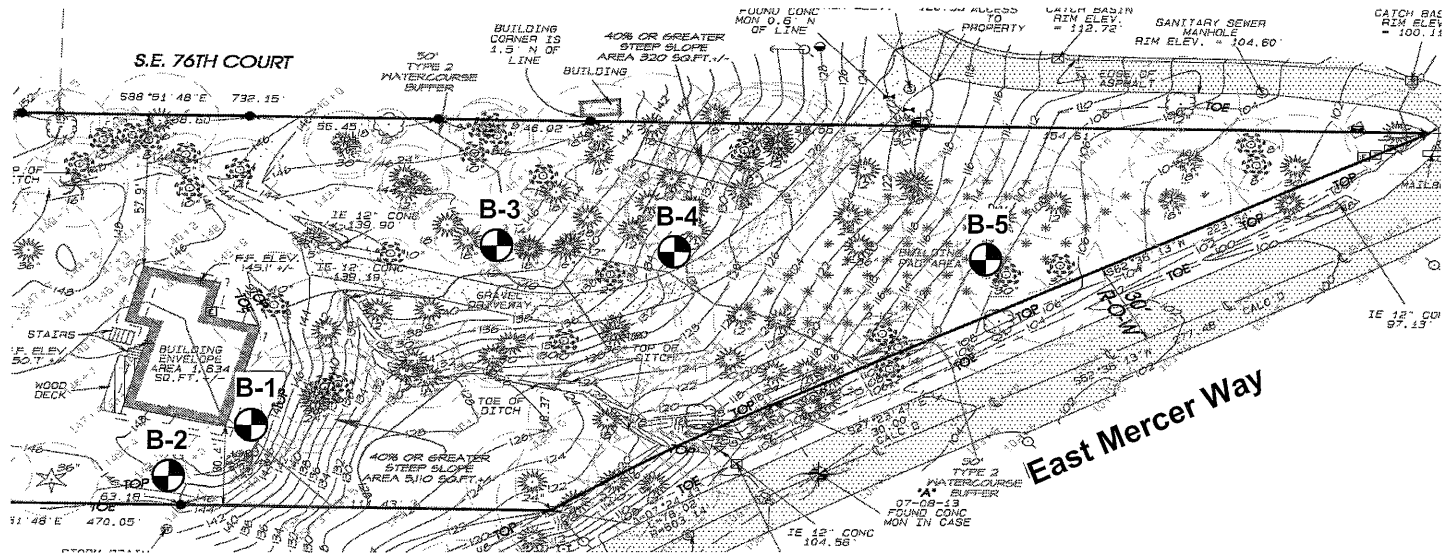
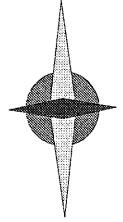

**Legend:**

 Boring Location



**SITE EXPLORATION PLAN**  
7216 East Mercer Way  
Mercer Island, Washington

Job No: 16095	Date: April 2016	No Scale	Plate: 2
------------------	---------------------	----------	-------------

**NORTH**

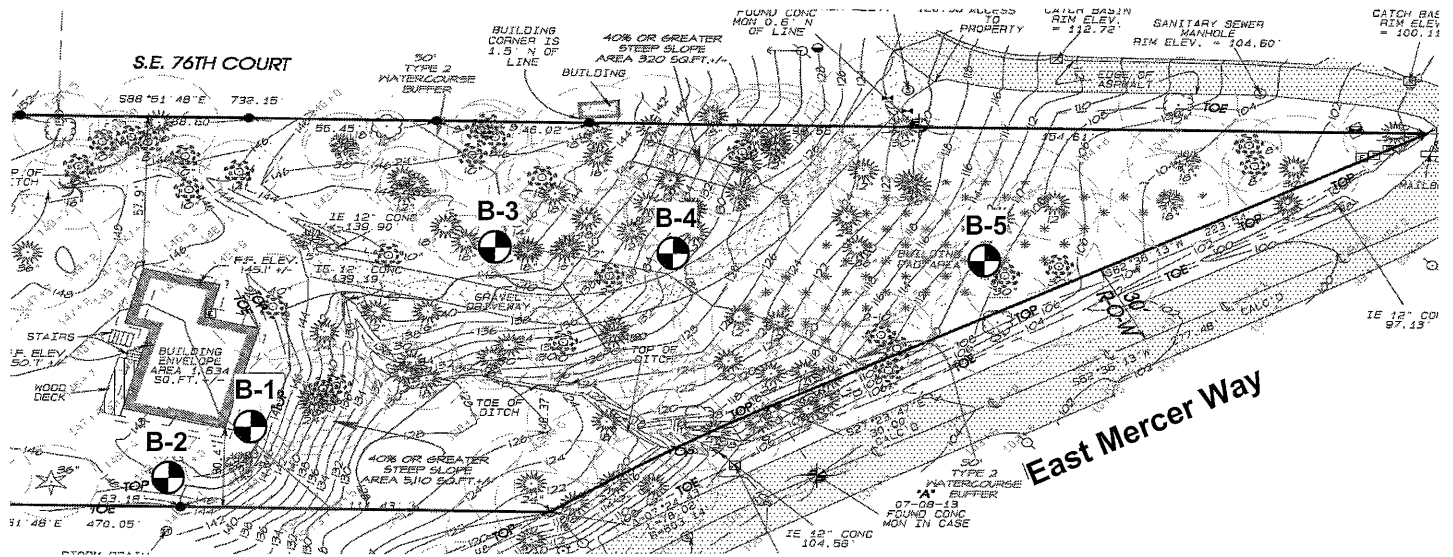
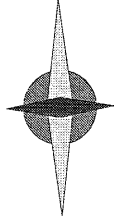

**Legend:**

-  Boring Location
-  Test Pit Location



**SITE EXPLORATION PLAN**  
7216 East Mercer Way  
Mercer Island, Washington

Job No: 16095	Date: April 2016	No Scale	Plate: 2
------------------	---------------------	----------	-------------

# BORING 1

Depth (ft.)  
Moisture  
Water  
Table  
Blows  
per Foot  
Sample  
USCS

Description

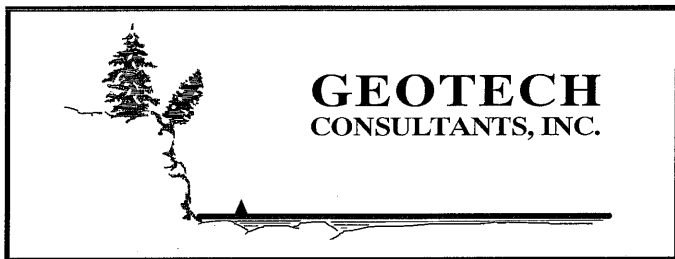
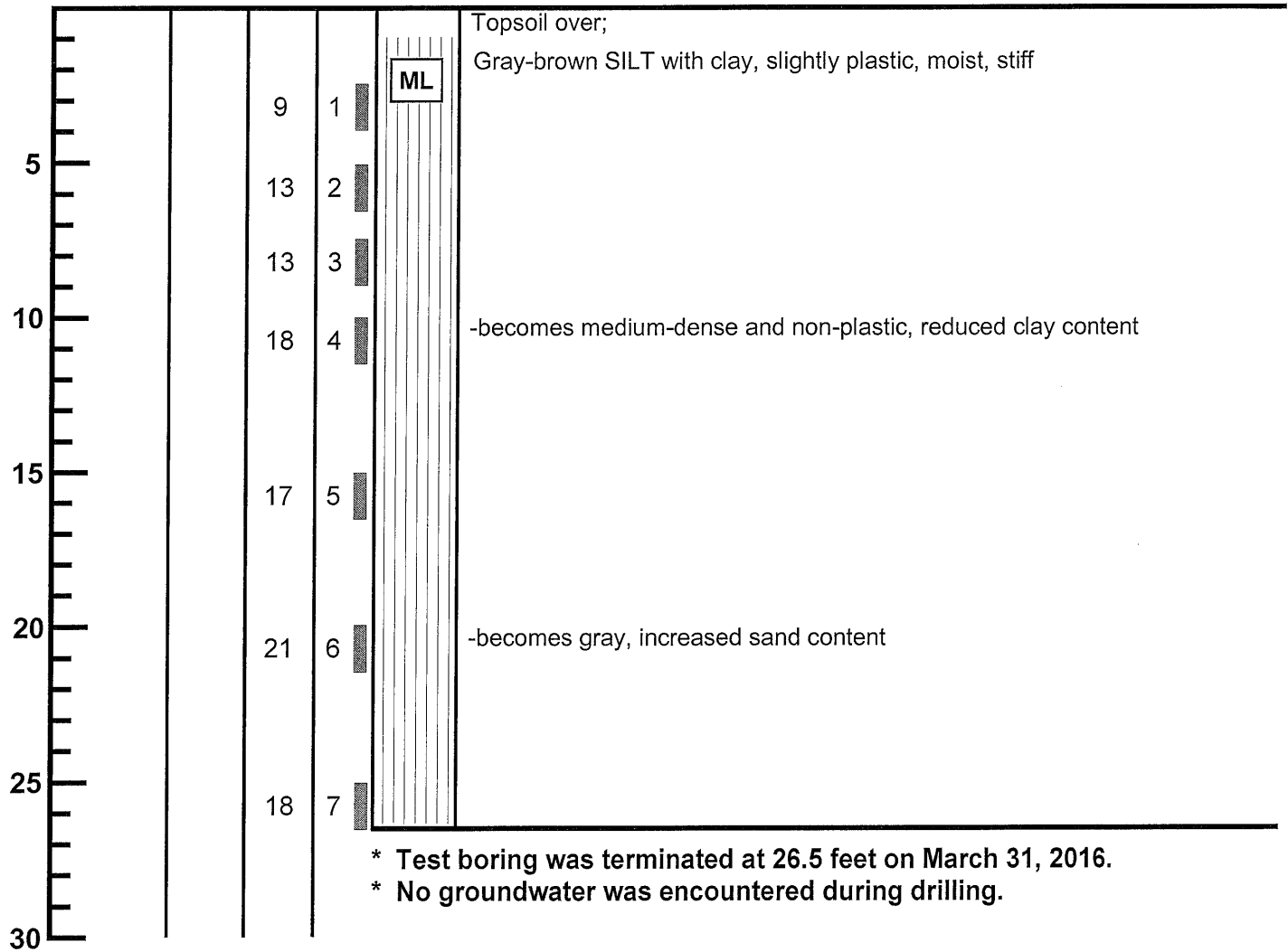

**TEST BORING LOG**  
7615 East Mercer Way  
Mercer Island, Washington

<b>Job</b> 16095	<b>Date:</b> March 2016	<b>Logged by:</b> TRC	<b>Plate:</b> 3
---------------------	----------------------------	--------------------------	--------------------

# BORING 2

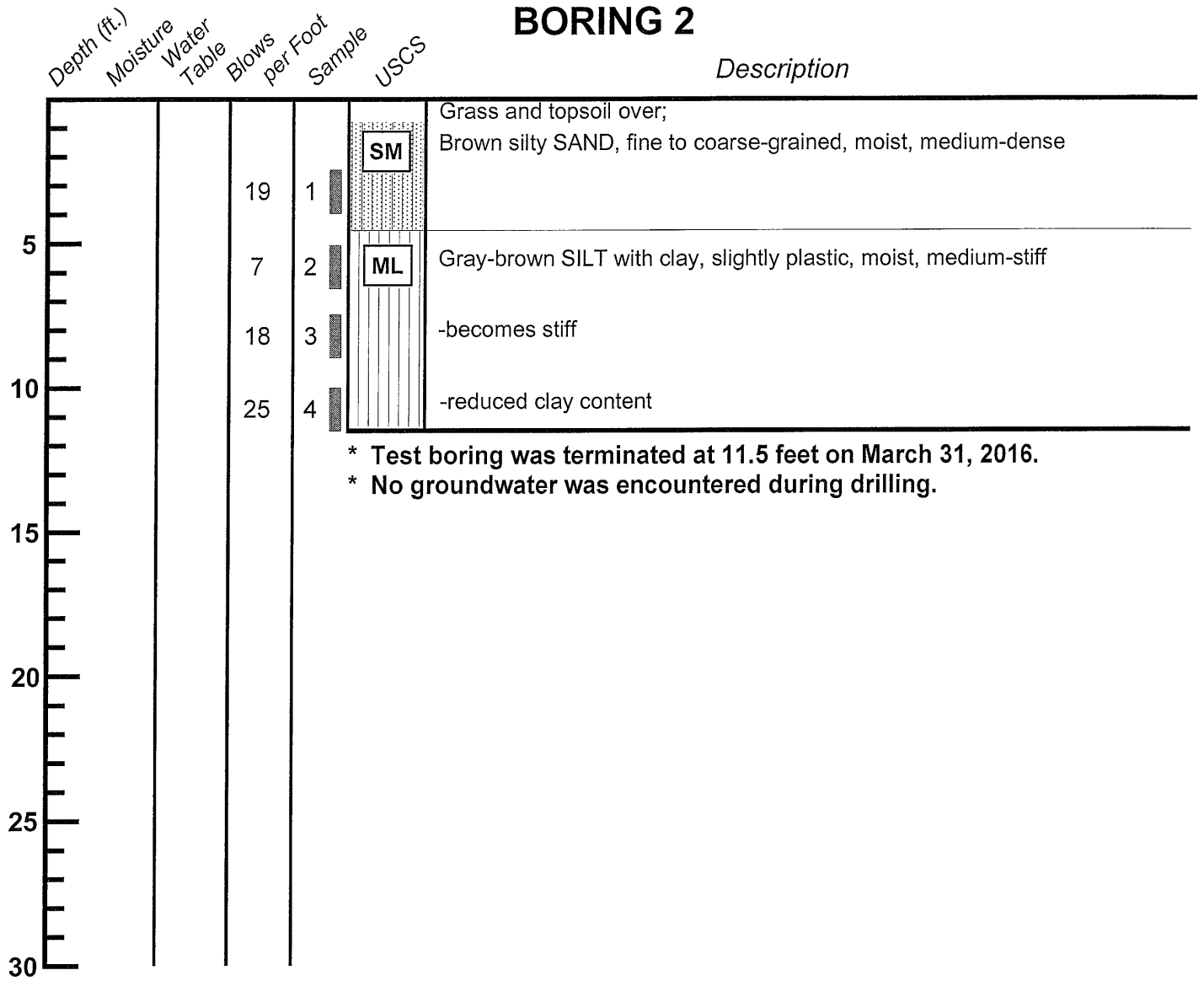

\* Test boring was terminated at 11.5 feet on March 31, 2016.  
 \* No groundwater was encountered during drilling.



**TEST BORING LOG**  
 7615 East Mercer Way  
 Mercer Island, Washington

<b>Job</b> 16095	<b>Date:</b> March 2016	<b>Logged by:</b> TRC	<b>Plate:</b> 4
---------------------	----------------------------	--------------------------	--------------------

# BORING 3

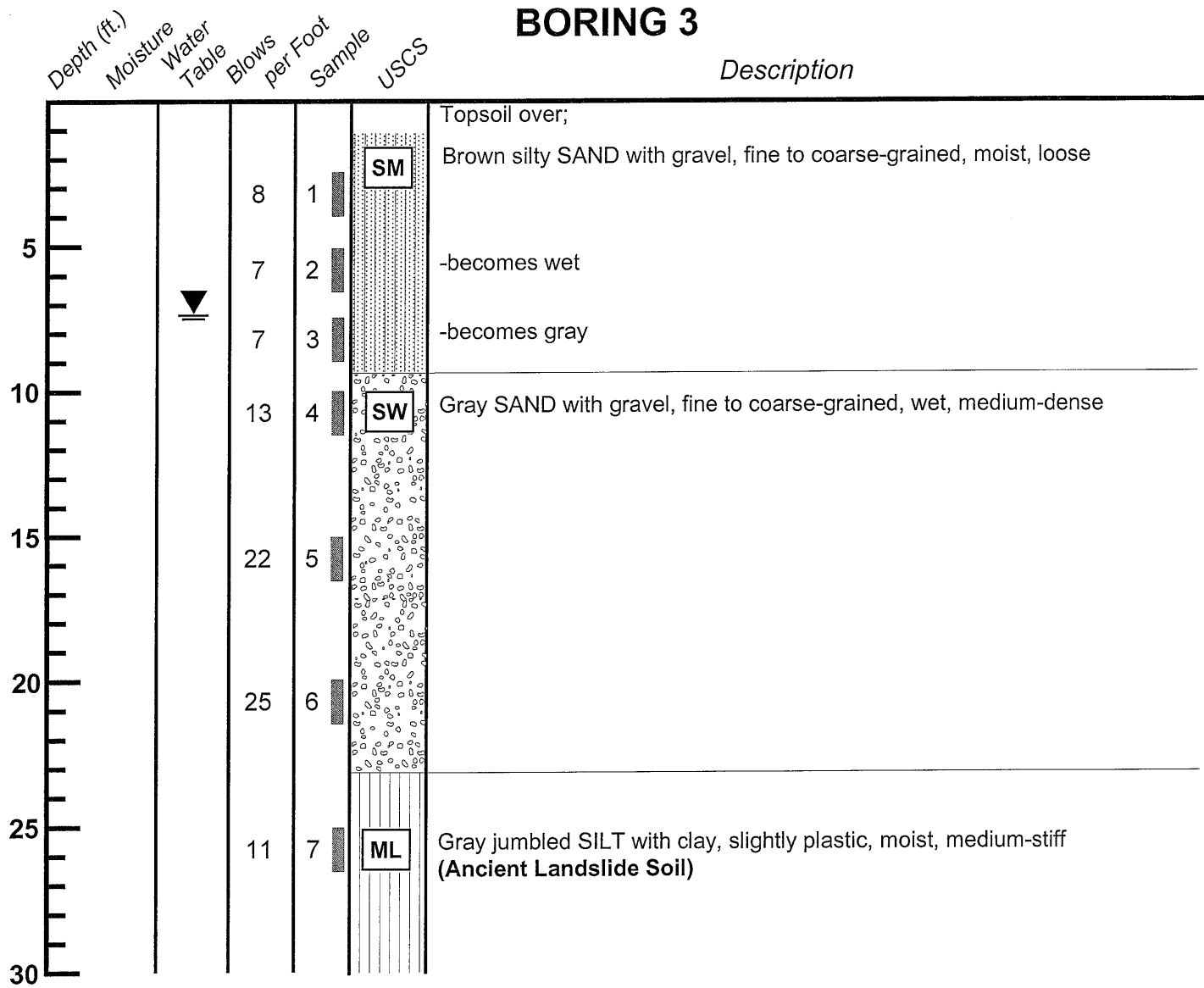

\* Continued on Plate 6.



**TEST BORING LOG**  
 7615 East Mercer Way  
 Mercer Island, Washington

<b>Job</b> 16095	<b>Date:</b> March 2016	<b>Logged by:</b> TRC	<b>Plate:</b> 5
---------------------	----------------------------	--------------------------	--------------------

Depth (ft.)  
Moisture  
Water  
Table  
Blows  
per Foot  
Sample  
USCS

# BORING 3 (CONTINUED)

Description

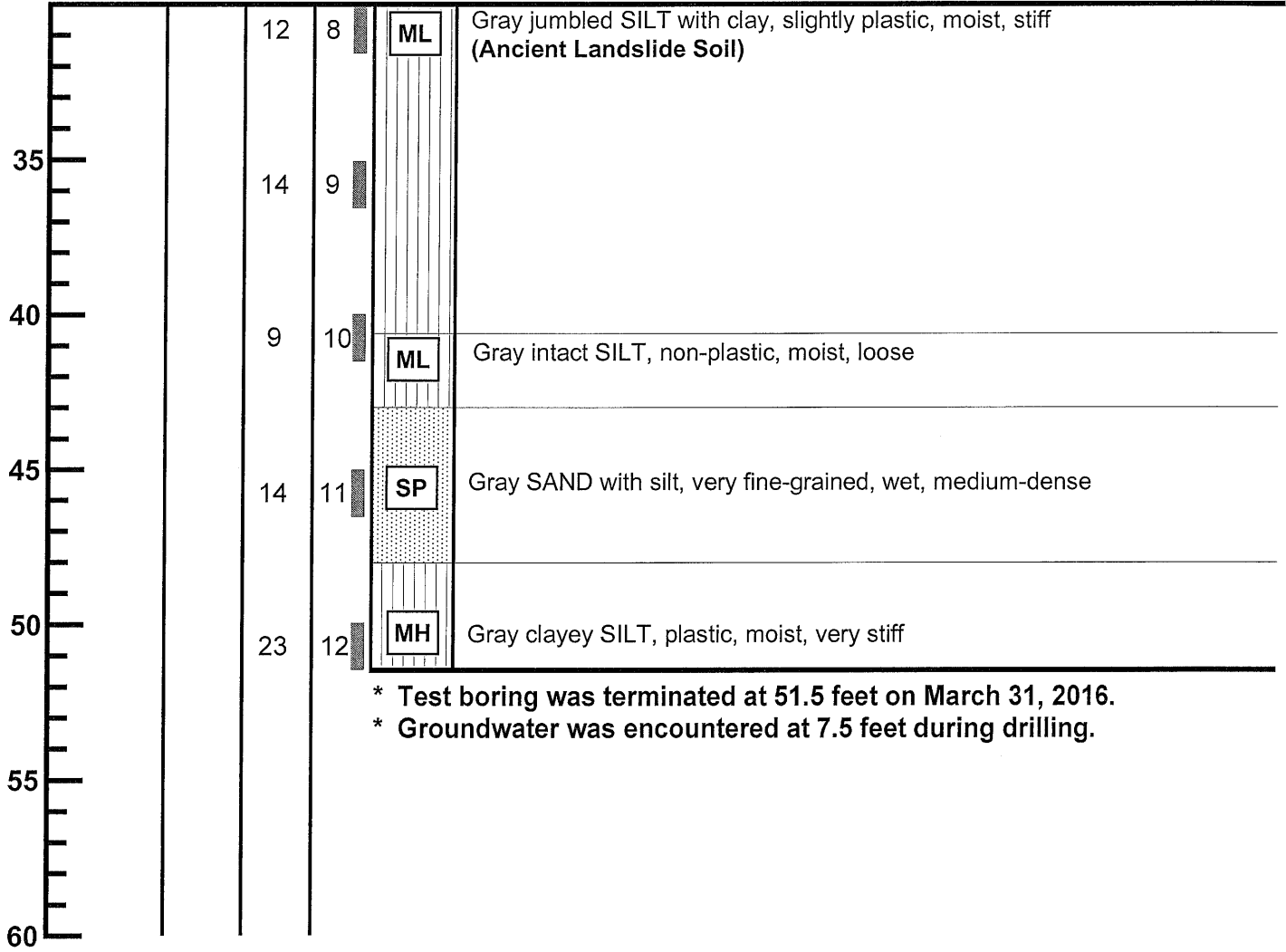

- \* Test boring was terminated at 51.5 feet on March 31, 2016.
- \* Groundwater was encountered at 7.5 feet during drilling.



**TEST BORING LOG**  
7615 East Mercer Way  
Mercer Island, Washington

<b>Job</b> 16095	<b>Date:</b> March 2016	<b>Logged by:</b> TRC	<b>Plate:</b> 6
---------------------	----------------------------	--------------------------	--------------------

# BORING 4

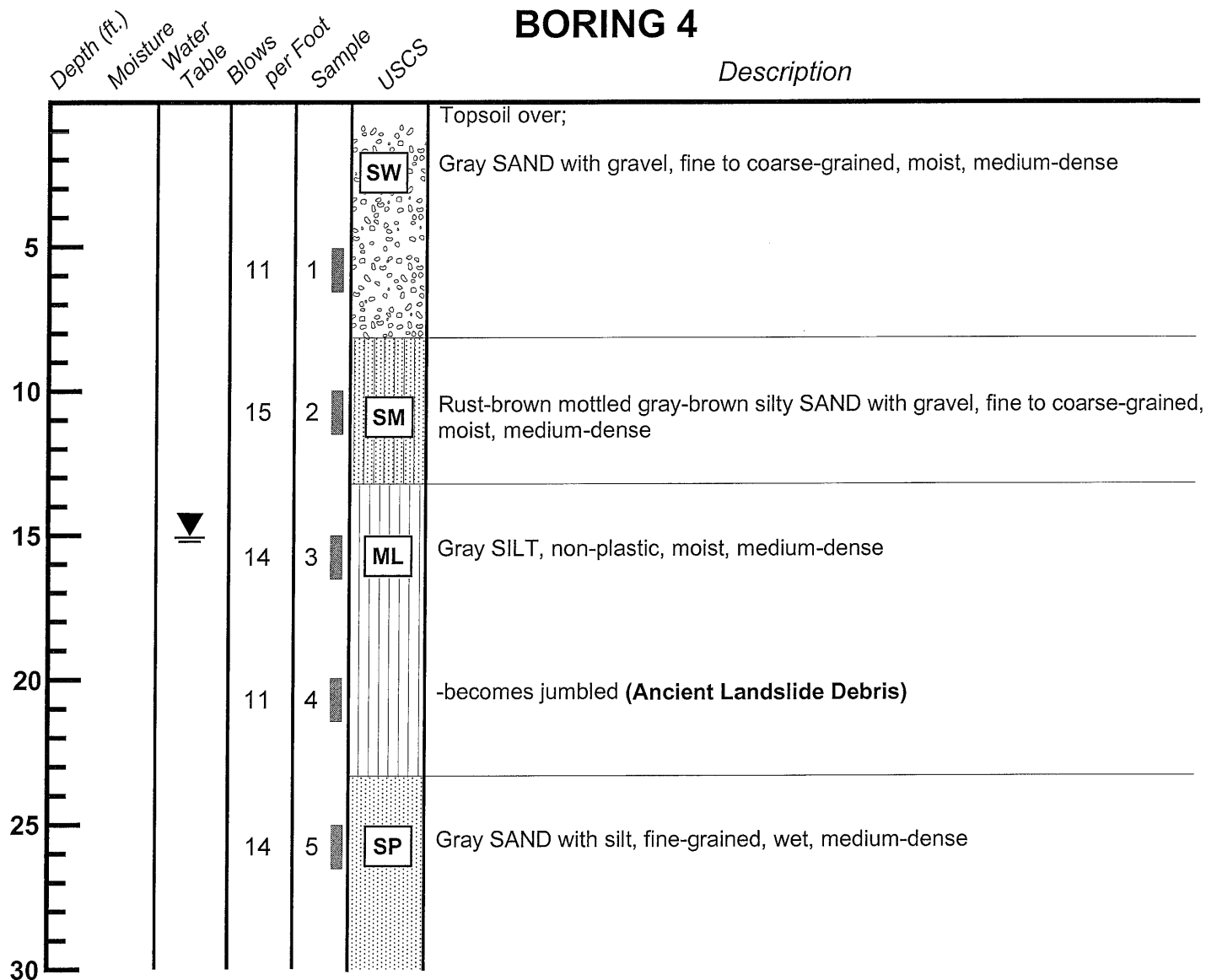

\* Continued on Plate 8.



**TEST BORING LOG**  
7615 East Mercer Way  
Mercer Island, Washington

<b>Job</b> 16095	<b>Date:</b> March 2016	<b>Logged by:</b> TRC	<b>Plate:</b> 7
---------------------	----------------------------	--------------------------	--------------------

Depth (ft.)  
 Moisture  
 Water  
 Table  
 Blows  
 per Foot  
 Sample  
 USCS

# BORING 4 (CONTINUED)

Description

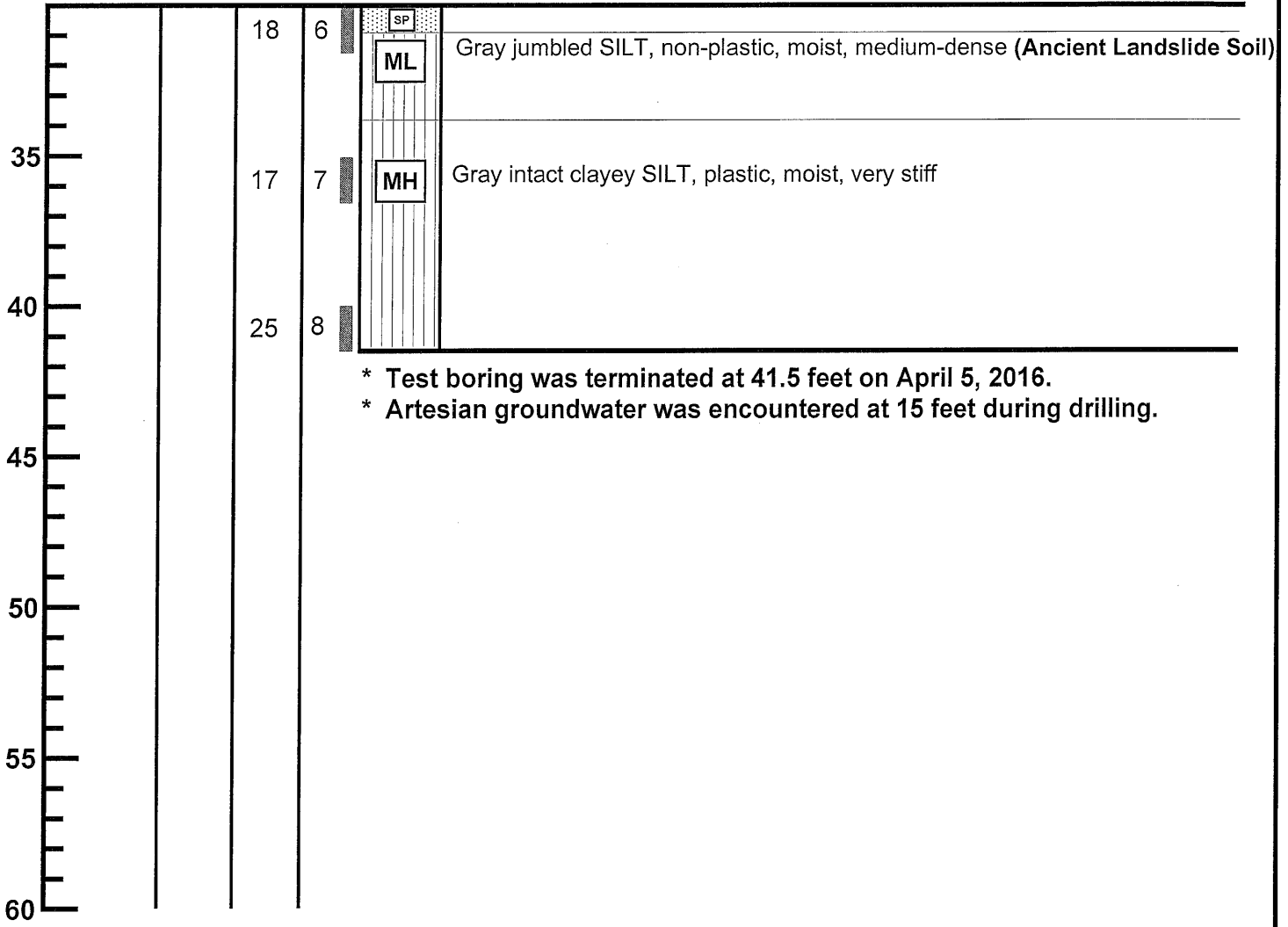

\* Test boring was terminated at 41.5 feet on April 5, 2016.  
 \* Artesian groundwater was encountered at 15 feet during drilling.



**TEST BORING LOG**  
 7615 East Mercer Way  
 Mercer Island, Washington

<b>Job</b> 16095	<b>Date:</b> March 2016	<b>Logged by:</b> TRC	<b>Plate:</b> 8
---------------------	----------------------------	--------------------------	--------------------

# BORING 5

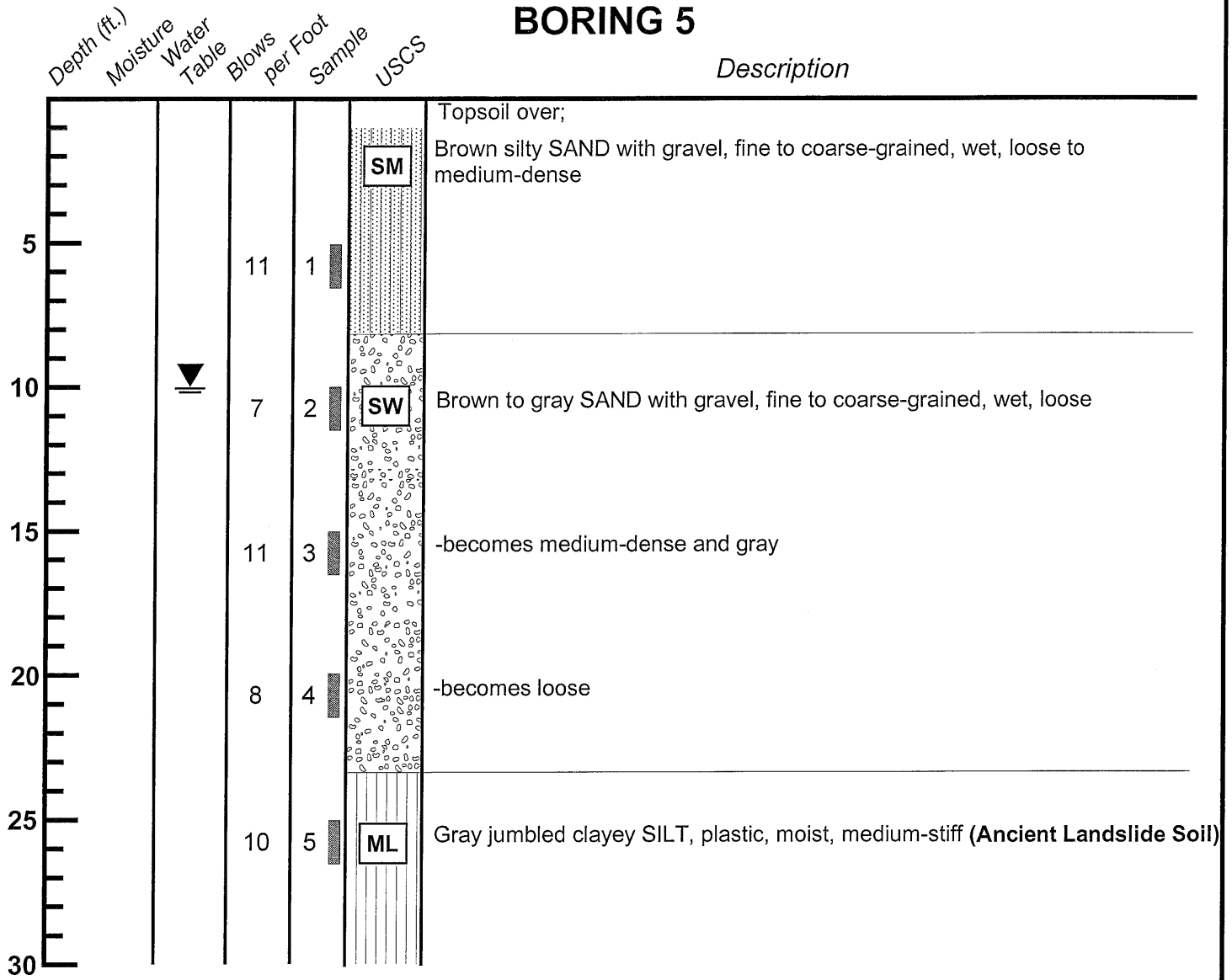

\* Continued on Plate 8.



**TEST BORING LOG**  
7615 East Mercer Way  
Mercer Island, Washington

<b>Job</b> 16095	<b>Date:</b> March 2016	<b>Logged by:</b> TRC	<b>Plate:</b> 9
---------------------	----------------------------	--------------------------	--------------------

Depth (ft.)  
Moisture  
Water  
Table  
Blows  
per Foot  
Sample

# BORING 5 (CONTINUED)

Description

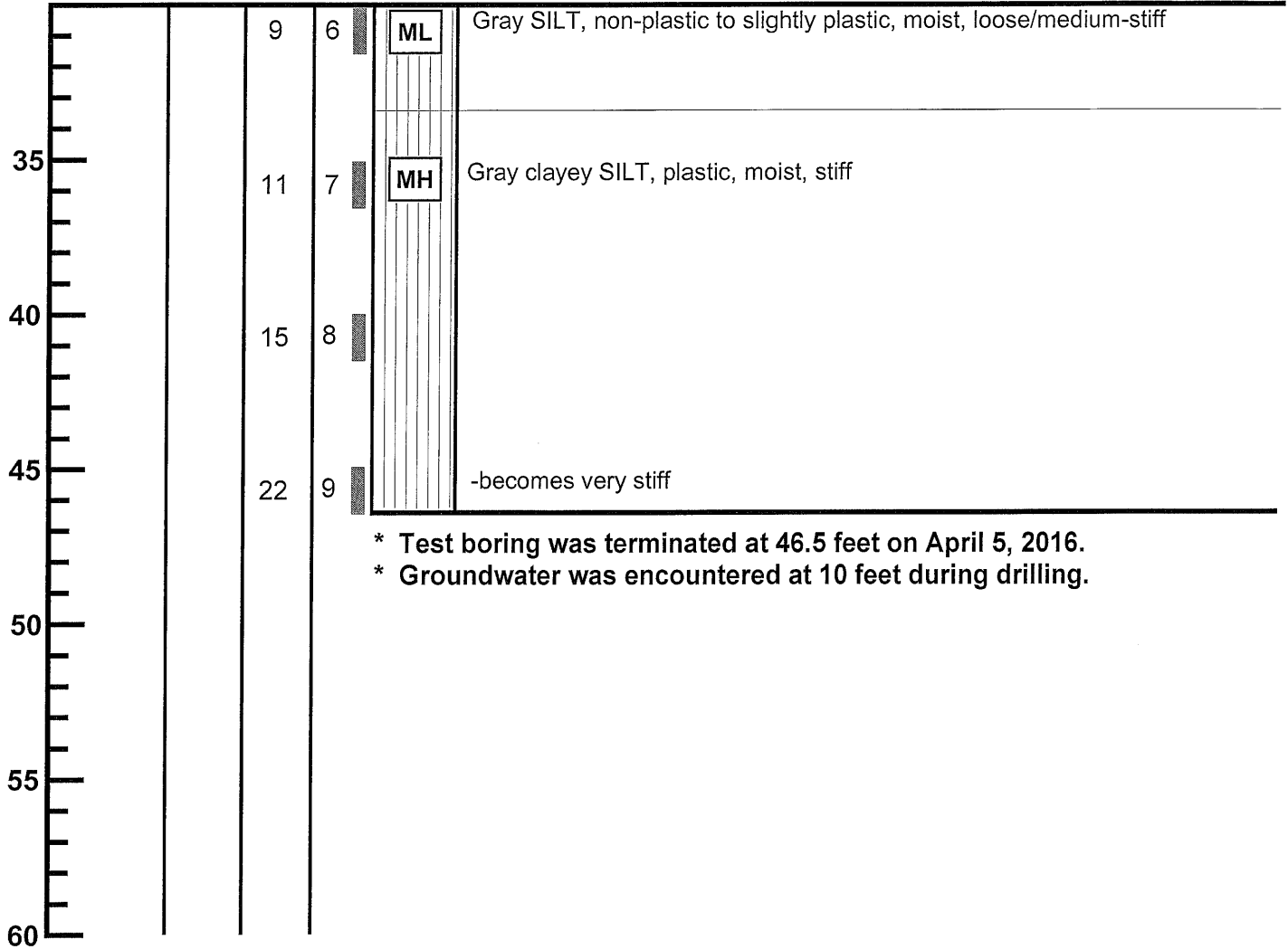

- \* Test boring was terminated at 46.5 feet on April 5, 2016.
- \* Groundwater was encountered at 10 feet during drilling.



**TEST BORING LOG**  
7615 East Mercer Way  
Mercer Island, Washington

<b>Job</b> 16095	<b>Date:</b> March 2016	<b>Logged by:</b> TRC	<b>Plate:</b> 10
---------------------	----------------------------	--------------------------	------------------

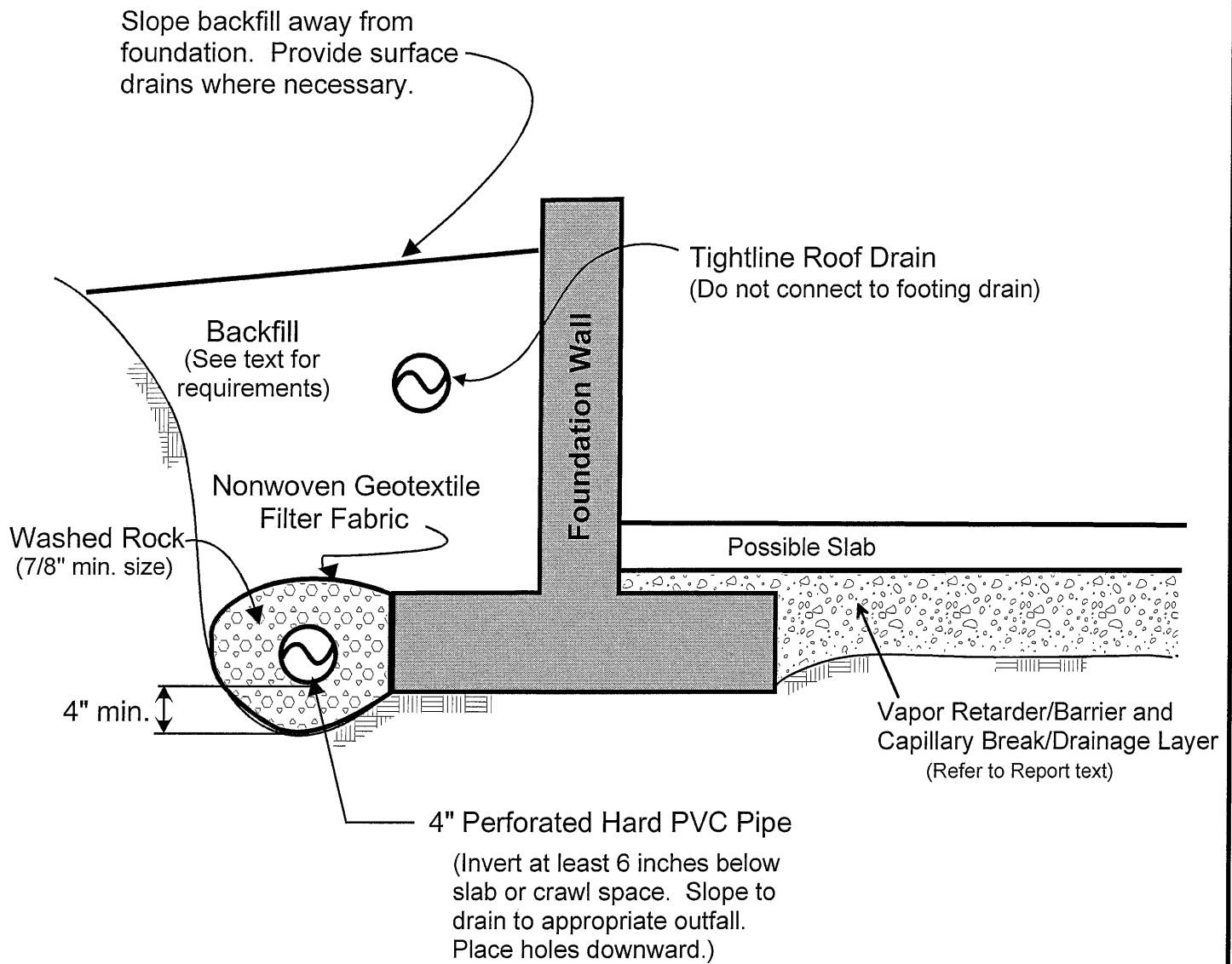

**NOTES:**

- (1) In crawl spaces, provide an outlet drain to prevent buildup of water that bypasses the perimeter footing drains.
- (2) Refer to report text for additional drainage, waterproofing, and slab considerations.



**FOOTING DRAIN DETAIL**  
7216 East Mercer Way  
Mercer Island, Washington

Job No: 16095	Date: April 2016	Plate: 11
------------------	---------------------	--------------

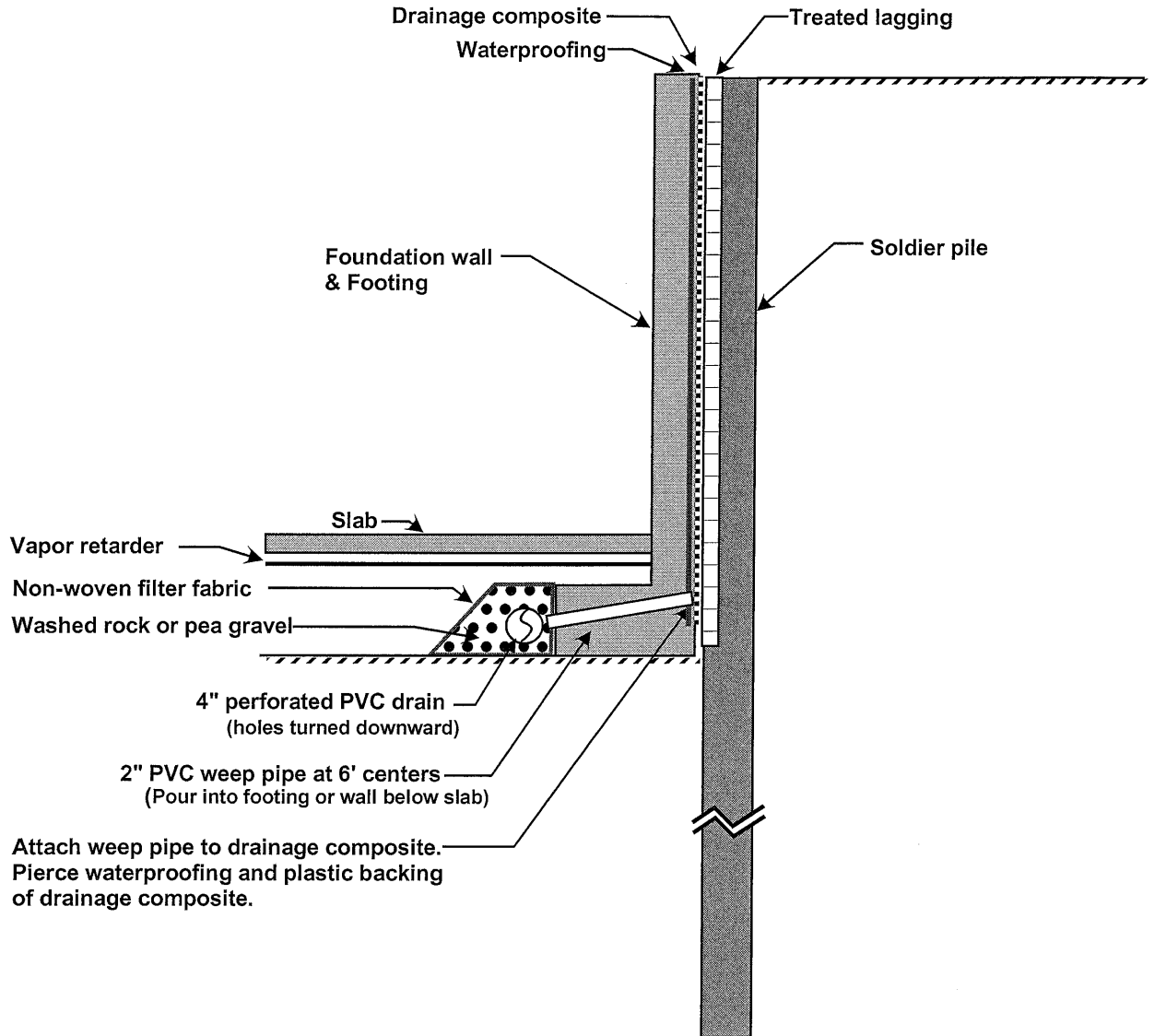

Attach weep pipe to drainage composite.  
Pierce waterproofing and plastic backing  
of drainage composite.

**Note** - Refer to the report for additional considerations related to drainage and waterproofing.



**SHORING DRAIN DETAIL**  
7216 East Mercer Way  
Mercer Island, Washington

Job No: 16095	Date: April 2016	Plate: 12
------------------	---------------------	--------------

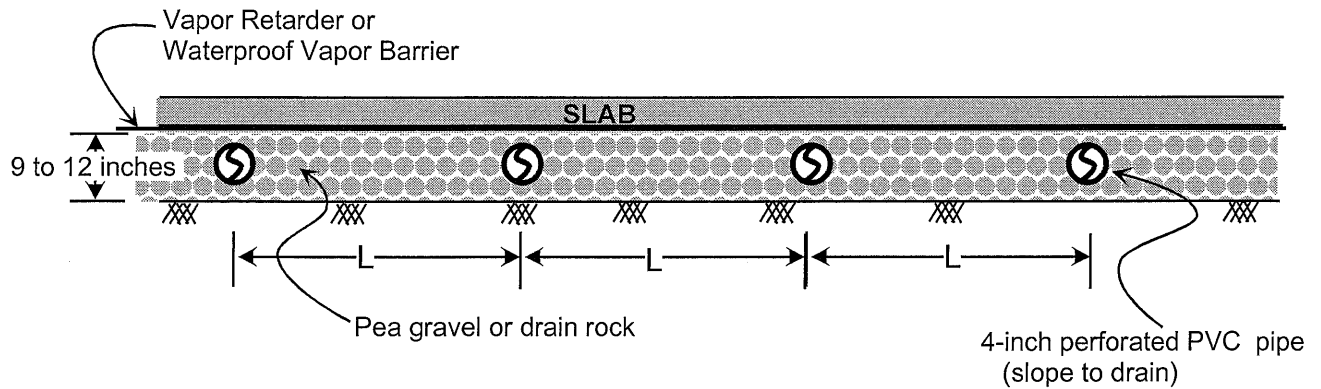

**NOTES:**

- (1) Refer to the report text for additional drainage and waterproofing considerations.
- (2) The typical maximum underslab drain separation (L) is 15 to 20 feet.
- (3) No filter fabric is necessary beneath the pipes as long as a minimum thickness of 4 inches of rock is maintained beneath the pipes.
- (4) The underslab drains and foundation drains should discharge to a suitable outfall.



**TYPICAL UNDERSLAB DRAINAGE**  
 7615 East Mercer Way  
 Mercer Island, Washington

Job No: 16095	Date: April 2016	Plate: 13
------------------	---------------------	--------------



## **APPENDIX C**

### Construction Stormwater Pollution Prevention Plan (SWPPP)

## CHESHIRE RESIDENCE

### CONSTRUCTION SWPPP NARRATIVE

### MARCH 7, 2025

The following Construction Storm Water Pollution Prevention Plan (SWPPP) narrative is for the Cheshire Residence project at 7615 East Mercer Way in Mercer Island, Washington. The narrative supplements the Temporary Erosion and Sediment Control (TESC) plan. This narrative and the drawings address the requirements of Volume II of the 2014 Department of Ecology (DOE) Stormwater Management Manual for Western Washington. Refer to the TESC plan (Sheet C1.0) and TESC details & notes (Sheet C1.1) for more information regarding any erosion or sedimentation control measures involved in this project.

#### I. CONSTRUCTION STORMWATER POLLUTION PREVENTION ELEMENTS

- 1) **Mark Clearing Limits:** Clearing limits will be delineated on the TESC and Site Demolition plan. The actual limits of clearing will likely be smaller than the limit of work, but this identifies the maximum extent of the clearing limits. Areas impacted and not anticipated to be covered with final measures shall be stabilized using approved permanent TESC methods.
- 2) **Establish Construction Access:** Construction access will be provided via the existing concrete driveway from W Mercer Way. The Contractor shall provide wheel wash if necessary.
- 3) **Control Flow Rates:** Stormwater flow control during construction is anticipated to be mitigated by routing runoff to a temporary sediment settling tank. Refer to the Sediment Facility Sizing calculations and the MGS Flood output included within Appendix B of the project's stormwater site plan.
- 4) **Install Sediment Controls:** DOE approved BMPs for sediment controls are shown on the TESC plan. Sediment will be controlled using silt fence (BMP C233) and Sediment Control Facility BMP C241.
- 5) **Stabilize Soils:** It is possible that some of the earthwork and grading may occur in wet weather conditions. The site must be stabilized and no soils will be allowed to remain unstabilized for more than two days between October 1<sup>st</sup> and April 30<sup>th</sup>. From May 1 through September 30, install cover measures to protect disturbed areas that will remain unworked for seven days or more. By October 8, seed all areas that will remain unworked from October 1 through April 30. Mulch all seeded areas.

Exposed slopes will be protected by DOE-approved coverage methods. BMPs including, but not limited to: C101, Preserving Natural Vegetation; C121, Mulching; C123, Plastic Covering; C130, Surface Roughening; C140, Dust Control; and T5.13 Post Construction Soil Amendment will be used to stabilize on-site soils during construction.

- 6) **Protect Slopes:** The DOE-approved BMPs for slope protection will be utilized during construction. Concentrated discharges shall not be allowed to flow over the top of steep slopes. BMPs including, but not limited to C101, Preserving Natural Vegetation and C233, Silt Fence are to be utilized to protect slopes during construction.

- 7) **Protect Drain Inlets:** Drainage structures in areas where no work occurs will remain and will be protected; discharge points to the public storm drain main line will also be protected. To prevent discharge of turbid water downstream, all existing catch basins located within the disturbance area and outside of the disturbance area within approximately 300 feet downstream of the site will be protected with storm drain inlet protection (BMP C220). The Contractor shall remove inlet protection at the end of the project without releasing captured sediment into the storm system.
- 8) **Stabilize Channels and Outlets:** Channels are not proposed as part of this project and BMPs for channel stabilization are not expected. DOE-approved BMPs for channel stabilization include, but are not limited to: C200, Interceptor Dike and Swale; and C207, Check Dams.
- 9) **Control Pollutants:** Temporary protection of the disturbed soils provides the first level of protection for pollution control, and perimeter measures downstream will mitigate the remaining pollutants. The temporary protection of disturbed soils may be mitigated with a temporary sump and pump facility to provide the second level of interception of pollutants. This collection system filters sediments prior to the pump system. The pump system will then route stormwater via force mains into the temporary sediment settling tank. Construction debris will be removed from the site. The Contractor will be responsible for managing their construction equipment per DOE-approved BMPs. If a truck wheel wash is required, truck wheel wash water and concrete truck washout water shall be collected and discharged to the public sanitary sewer (SS) system. To apply for and obtain a SS release, contact the local sewer purveyors (City of Mercer Island and King County Metro) for authorization.
- 10) **Control De-Watering:** The majority of the earthwork on the project will be constructed during the dry season, therefore it is not anticipated that groundwater will be encountered in the excavations for this project. In the event that perched groundwater is encountered during any wet season construction, the Contractor shall route it to the sediment settling facility by pumping it out of the excavation.
- 11) **Maintain BMPs:** DOE-approved standard BMP maintenance will be required in accordance with the DOE standard TESC plan notes (Sheet C1.1).
- 12) **Manage the Project:** All phases of construction will be managed by the Contractor. The site must be stabilized and no soils will be allowed to remain exposed and unworked for more than two days between October 1<sup>st</sup> and April 30<sup>th</sup> and for more than seven days between May 1<sup>st</sup> and September 30<sup>th</sup>. The Contractor will provide maintenance and monitoring of TESC BMPs. Work of all contractors will be coordinated to minimize the duration of disturbance on the site. The best management practices shown on the TESC plan are minimum requirements. Failure to maintain SWPPP measures in accordance with adopted standards may result in the work being performed at the City's direction and the costs assessed as a lien against the property where such facilities are located.
- 13) **Protect LID BMPs:** There are no proposed LID facilities associated with this project, and therefore protection for element 13 is not required.

## 2. PROJECT DESCRIPTION

The proposed project will include replacing the existing single-family residence with the construction of a new single-family residence, as well as, reconstructing the existing driveway between the existing detached accessory dwelling unit (DADU) and the new residence.

The project proposes 9,191 square-feet (0.211 acres) of new plus replaced hard surface. Flow control is not required, as the site directly discharges to a flow control-exempt surface water (Lake Washington). Runoff treatment is not required because the project proposes less than 5,000 square feet of pollution-generating hard surface and less than  $\frac{3}{4}$  acre of pollution-generating pervious surface. Refer to the project's stormwater site plan for more information.

## 3. EXISTING SITE CONDITIONS

The property (Parcel #3024059036) is currently developed with an existing residence, DADU and driveway and has a total area of approximately 77,402 square feet (1.78 acres). Topography for the site slopes down from the northwest to the east towards E Mercer Way from a high elevation of approximately 260-feet. The low point on the site is at approximately 120-feet along the east property line.

Per the King County iMap, the project is within the Cedar River – Lake Washington Watershed. Runoff from the site is generally collected in catch basins and conveyed southeast to the discharge point to Lake Washington.

## 4. ADJACENT AREAS

The site is bounded by single-family residences to the north, west, and south. Vehicular access is to the east, via E Mercer Way.

## 5. CRITICAL AREAS

King County critical areas mapping indicates that the entire site is located in a designated Erosion Hazard area. Additionally, according to the City of Mercer Island GIS mapping system, there are Steep Slope and Erosion Hazard areas in the western undeveloped regions of the site and Seismic and Potential Slide Hazard areas over the entire site.

## 6. SOILS

Per the Natural Resources Conservation Service Web Soil Survey, the entire site is underlain with Kitsap silt loam, 15 to 30 percent slopes (KpD). A geotechnical report was previously prepared by Geotech Consultants Inc., dated May 2, 2016, for the construction of the DADU located on the site. The report indicates that the site soils near the existing residence consists of medium-stiff to medium dense native soils. Also based upon the mature, straight, evergreen trees and no signs of distress in the existing foundation, there was no evidence of significant slope movement within the last 50 years. Groundwater seepage was observed in three borings along the north side of the property, ranging in depths from 7.5 to 10 feet. The City of Mercer Island Infiltration Feasibility Map shows as located in "Basin 38", in an area where both infiltration is infeasible and infiltration facilities are not permitted.

## **7. POTENTIAL EROSION PROBLEM AREAS**

The site is within an erosion hazard area. Therefore, per the proposed contract documents, the contractor is to provide protection for soils to limit the exposure to erosion. The limitation of disturbance, adequate cover practices, seasonal work limitation, and runoff control are the most effective methods for reduction of turbidity in stormwater runoff. Any runoff that occurs will be directed to the temporary sump and then pumped to the sediment settling tank. Areas that have not been permanently stabilized must be addressed using DOE-approved BMPs, per the construction documents.

## **8. CONSTRUCTION PHASING**

At this time, it is not expected that the project will be formally phased. The contractor is responsible for coordinating work of all subcontractors to keep the duration of site disturbance limited to the maximum extent possible.

## **9. CONSTRUCTION SCHEDULE**

Construction is expected to begin in June 2025 and be completed by May 2026.

Earthwork activities are not expected to take place in the wet season, October 1<sup>st</sup> to April 30<sup>th</sup>. Should any wet weather conditions occur during construction, the contractor shall implement the de-watering procedures outlined in this SWPPP and applicable BMPs including, but not limited to C123, Plastic Covering; C121, Mulching; C122, Nets and Blankets; C126, Polyacrylamide for Soil Erosion Protection; C130, Surface Roughening.

## **10. FINANCIAL/OWNERSHIP RESPONSIBILITIES**

This property is owned and operated by the Derek and Eileen Cheshire. The accepted low bidder on the project will be responsible for posting a performance and payment bond with the Cheshires, and thus will be the responsible party for any liability associated with erosion and sedimentation impact.

## **11. ENGINEERING CALCULATIONS**

A copy of any calculations performed during design of the project and relevant storm drainage modeling discussions is included in the project's Stormwater Site Plan.



## **APPENDIX D**

### Geotechnical Report

September 15, 2023

JN 23177

Derek and Eileen Cheshire  
7615 East Mercer Way  
Mercer Island, Washington 98040

via email: [eileen@boskone.net](mailto:eileen@boskone.net) and [dcheshire@boskone.net](mailto:dcheshire@boskone.net)

Subject: **Transmittal Letter – Geotechnical Engineering Study and Critical Area Study**  
Proposed New Residence  
7615 East Mercer Way  
Mercer Island, Washington

Greetings;

Attached to this transmittal letter is our geotechnical engineering report and critical area study for the proposed residence to be constructed in Mercer Island, Washington. The scope of our services consisted of exploring site surface and subsurface conditions, and then developing this report to provide recommendations for general earthwork and design considerations for foundations, retaining walls, subsurface drainage, slope stability, and temporary excavations. This work was authorized by your acceptance of our proposal, P-11404, dated May 23, 2023.

The attached report contains a discussion of the study and our recommendations. Please contact us if there are any questions regarding this report, or for further assistance during the design and construction phases of this project.

Respectfully submitted,

GEOTECH CONSULTANTS, INC.



Matthew K. McGinnis  
Geotechnical Engineer

cc: **FORMWORKS DESIGN I BUILD** – Kyle Clark  
via email: [kyle@formworksdb.com](mailto:kyle@formworksdb.com)

MKM/DRW:kg

**GEOTECHNICAL ENGINEERING STUDY AND CRITICAL AREA STUDY**  
**Proposed New Residence**  
**7615 East Mercer Way**  
**Mercer Island, Washington**

This report presents the findings and recommendations of our geotechnical engineering study for the site of the proposed new residence to be located in Mercer Island.

Development of the property is in the planning stage, and detailed plans were not available to us at the time of this study. Based on a preliminary site plan provided to us by the project architect, we understand that a new residence will be constructed at the subject site. We understand that the residence will be similarly sited to the existing residence, but will expand to the north, west, and south from the existing residence footprint. The new residence will likely be two stories in height and may contain basement space that daylights to the north. A new parking area will be constructed north of the residence, following the existing driveway alignment, and other hardscaping will be located around the residence. Yard, landscaping, and patio spaces will populate the area west of the residence. No finish floor elevations or final building setbacks have been determined at the time of writing this report.

If the scope of the project changes from what we have described above, we should be provided with revised plans in order to determine if modifications to the recommendations and conclusions of this report are warranted.

**SITE CONDITIONS**

***SURFACE***

The Vicinity Map, Plate 1, illustrates the general location of the site on Mercer Island. The irregularly shaped property comprises a total site area of 1.7-acres. The site is bounded to the north, south, and west by residential parcels, and to the east by East Mercer Way.

The grade across the large site slopes downward from west to east, with a total elevation change of approximately 170 feet. The upland western approximate half of the site is undeveloped and is comprised of a moderate to steeply inclined slope that is populated with abundant trees and moderate to dense underbrush. Much of this slope is inclined from 35 to 40 percent, but localized steeper areas are present on this slope, where the slope is inclined from 50 to almost 80 percent. This western slope, in total, is on the order of 120 feet tall. A stream/drainage feature runs through this slope and appears to partially originate from surficial expression of a perched groundwater seam located on the slope. This stream alignment funnels to a ditch line located near the northern property line at the toe of this slope.

The eastern remaining developed half of the site is generally more moderately inclined. At the toe of the western slope, the grade carries out flat to gently sloped across a grass yard and driveway. This flat grade continues to the area of the existing, one-story residence. This residence contains a basement that daylights to the north. A DADU is located northeast of the residence and is accessed via a shared driveway that serves both the residence and DADU. East of the existing residence, the grade carries out flat for several feet before the elevation drops steeply across an approximate 20-foot-tall slope that is inclined at 60 percent. Past the toe of this slope, the grade becomes more

moderate, continuing to the eastern property line, where a shorter, 12-foot-tall steep slope is located adjacent to East Mercer Way.

The City of Mercer Island GIS indicates that the site is mapped as a Potential Landslide Hazard Area, Erosion Hazard Area, and a Seismic Hazard Area. A portion of the western, upland slope is mapped as a Steep Slope area on the GIS. Based on Mercer Island's criteria for steep slopes, a majority of the western slope would be considered steep, as well as the slope located east of the existing residence, and adjacent to East Mercer Way. The *Mercer Island Landslide Hazard Assessment* indicates that several mapped landslides have been recorded on, and within the general vicinity of the site. The hazard assessment maps the top of the western steep slope as a scarp feature, and maps the presence of shallow, surficial groundwater expression and spring locations throughout this slope. Mass wasting or colluvial soil deposits have been mapped within this area as well. These mappings appear to be based both on Lidar imagery, as well as available geologic maps. Based on our review of these maps, and our understanding of the general vicinity surrounding the site, this area of Mercer Island was part of a large historic landslide complex that caused large debris flows that traveled downslope from the mapped scarp west of the site, all the way into Lake Washington. Colluvial (landslide) soil deposits, as well as evidence of this previous large landslide have been encountered on various projects located east, and downslope of the subject site, and most notably, preserved trees can be seen off the south end of the island, where a large slide block apparently travelled into the lake.

We saw no signs of recent, deep seated instability on the site. However, the site's steep slopes are populated with sickly trees that were observed to be leaning, and few large, mature trees were observed on the site slopes. This can be an indicator that previous, shallow soil creep has occurred in the past. A majority of the slopes are covered with moderate to dense underbrush as well as scattered plantings.

The adjacent properties are all developed with larger residences located at least 10 feet from the property lines. The adjacent northern and southern residences are situated in terraced areas in a similar topographic profile to the site, and the western adjacent residence is located atop the tall, western slope, and is set well away from the site.

As previously mentioned, a Detached Accessory Dwelling Unit (DADU) is located northeast of the existing residence and is located within the site bounds near the northern property line. This DADU was constructed fairly recently, and our firm was involved in the design and construction of the DADU. As part of this phase of work, we completed a geotechnical report for the DADU construction, as well as a previous development scope related to the residence. This DADU was designed to be supported atop a deep foundation system due to soil conditions encountered during drilling of several borings.

## **SUBSURFACE**

We originally explored the subsurface conditions at the site by drilling five test borings in 2016 in preparation of a geotechnical engineering study at that time; the DADU noted earlier was in part constructed based on information in that study. Recently, we returned to the site to drill two, deeper test borings as part of the new project scope, as well as to address MICC code changes that have occurred since our 2016 report. at the approximate locations shown on the Site Exploration Plan, Plate 2. Our exploration program was based on the proposed construction, anticipated subsurface conditions and those encountered during exploration, and the scope of work outlined in our proposal.

The older test borings were drilled on March 31, 2016 using a track-mounted, hollow-stem auger drill. The recent test borings were drilled on June 14, 2023 with a larger, tracked drill. Samples were taken at approximate 2.5- to 5-foot intervals with a standard penetration sampler. This split-spoon sampler, which has a 2-inch outside diameter, is driven into the soil with a 140-pound hammer falling 30 inches. The number of blows required to advance the sampler a given distance is an indication of the soil density or consistency. A geotechnical engineer from our staff observed the drilling process, logged the test borings, and obtained representative samples of the soil encountered. The Test Boring Logs are attached as Plates 3 through 13.

### **Soil Conditions**

Test Borings 1, 2, 6, and 7 were drilled near the proposed residence. Beneath the ground surface, loose, disturbed fill soils, and jumbled native soils consisting of silt, sand and silty sand that contained organics and pieces of wood were revealed. These soils appear to have been subject to previous slope movement and have the appearance of landslide debris (colluvium/mass wastage deposits), which is in agreement with the landslide mapping of the site and surrounding area. While these soils were not reported to have been encountered in Test Borings 1 and 2, it is common to encounter larger, more intact-looking blocks of soil that slid as a large unit and may not have as obvious an appearance as landslide debris. In Test Borings 1 and 2, the native silt continued to the base of the borings at a depth of 11.5 to 26.5 feet. However, Test Borings 6 and 7 were drilled deeper due to the use of a recently available larger limited access drill rig, and colluvial soils were encountered to a depth of approximately 31 to 36 feet. Below these depths, medium-stiff silt that were non-colluvial in appearance were revealed. Observance of soils samples within Test Boring 7 would indicate that some of the upper, wet sandier soils may have been associated with older surficial erosion from the nearby watercourse. The non-colluvial silt continued with depth and became very stiff beneath a depth of 42 feet in Test Boring 6, continuing to the base of the boring at a depth of 56.5 feet.

The remainder of the test borings were drilled throughout the eastern half of the site and generally encountered similar soil profiles. Loose fill, colluvial, stream deposits, and older landslide debris were revealed in these borings to depths of 33 to 41 feet, where silts more intact in appearance were encountered. Very stiff silts were encountered beneath depths of 33 to 50 feet in these borings, and continued to the base of these explorations, at depths of 41.5 to 51.5 feet.

No obstructions were revealed by our explorations. However, debris, buried utilities, and old foundation and slab elements are commonly encountered on sites that have had previous development.

### **Groundwater Conditions**

Perched groundwater seepage was observed at depths ranging from 2.5 to 35.5 feet in most of the test borings. This water was generally observed to be contained within perched zones of wet sand of varying thickness, with shallower water levels encountered near the stream alignment. More notably, artesian (pressurized) groundwater was encountered at a depth of 15 feet in Test Boring 3 within a confined sand layer. The test borings were left open for only a short time period. Therefore, the seepage levels on the logs represent the location of transient water seepage and may not indicate the static groundwater level. Groundwater levels encountered during drilling can be deceptive because seepage into the boring can be blocked or slowed by the auger itself. Also, it should be noted that groundwater levels vary

seasonally with rainfall and other factors. We anticipate that groundwater could be found in more permeable soil layers, and fracture zones in the silt and clay.

The stratification lines on the logs represent the approximate boundaries between soil types at the exploration locations. The actual transition between soil types may be gradual, and subsurface conditions can vary between exploration locations. The logs provide specific subsurface information only at the locations tested. If a transition in soil type occurred between samples in the borings, the depth of the transition was interpreted. The relative densities and moisture descriptions indicated on the test boring logs are interpretive descriptions based on the conditions observed during drilling.

### **SEISMIC CONSIDERATIONS**

In accordance with the International Building Code (IBC), the site class within 100 feet of the ground surface is best represented by Site Class Type F (Failure-Prone). However, the ASCE allows for an exemption from the F-classification if the building period is less than 0.5 seconds. The residence will very likely be of light-weight wood and timber construction and will have a building period less than 0.5 seconds, and thus a Site Class E can be used. As noted in the USGS website, the mapped spectral acceleration value for a 0.2 second ( $S_s$ ) and 1.0 second period ( $S_1$ ) equals 1.45g and 0.50g, respectively.

The IBC and ASCE 7 require that the potential for liquefaction (soil strength loss) during an earthquake be evaluated for the peak ground acceleration of the Maximum Considered Earthquake (MCE), which has a probability of occurring once in 2,475 years (2 percent probability of occurring in a 50-year period). The MCE peak ground acceleration adjusted for site class effects (FPGA) equals 0.68g. Sandy, saturated soils beneath the site are susceptible to seismic liquefaction under the ground motions of the MCE due to the presence of near-surface groundwater.

Sections 1803.5 of the IBC and 11.8 of ASCE 7 require that other seismic-related geotechnical design parameters (seismic surcharge for retaining wall design and slope stability) include the potential effects of the Design Earthquake. The peak ground acceleration for the Design Earthquake is defined in Section 11.2 of ASCE 7 as two-thirds ( $2/3$ ) of the MCE peak ground acceleration, or 0.45g.

### **SUMMARY OF SLOPE STABILITY ANALYSIS**

We utilized the Slope/W computer program to assess the stability of the site related to the proposed residence. The results of the slope stability analyses for both static and seismic conditions are attached to the end of this report as Appendix A. According to the International Building Code (IBC) and ASCE 7, the Design Earthquake for seismic analyses is equal to two-thirds of the Maximum Considered Earthquake (MCE). As noted in the report, the peak ground acceleration for the MCE is 0.68g. However, Mercer Island's third party reviewers have recently been requesting that slope stability analyses utilize a value equal to one half of the MCE. For the seismic slope analyses for this report, we have utilized this higher seismic coefficient equal to one-half of the MCE, or 0.34g.

A stability scenario pertaining to the proposed post-construction condition was analyzed for this report. This scenario is related to a potential deep-seated failure within the colluvial soils encountered in our borings beneath the residence location. To meet MICC slope stability standards with regards to this scenario, a below-grade stabilization wall will need to be constructed on the eastern perimeter of the development area. As noted in more detail later in this study, this

stabilization wall would consist of closely-spaced, drilled soldier piles that are designed to retain against the depth of the potential failure in this scenario. Based on our analysis, the stabilization wall would need to be designed to retain to a depth of 45 feet beneath the existing site grades in order to meet Mercer Island Slope Stability criteria. The wall would gain its lateral capacity from sufficient embedment into the underlying very stiff silts, and depending on the wall design, additional lateral support in the form of anchor tiebacks may be needed in order to supplement the design. In utilizing these recommended systems, the slope stability analysis confirms that the safety factor against a failure beneath the residence is in excess of 1.1 and 1.5 for seismic and static conditions, respectively.

The slope stability analyses are included at the end of this report as Appendix A. Due to the preliminary nature of this project, the cross sections do not fully show excavations for foundations, or other site developments.

## **CONCLUSIONS AND RECOMMENDATIONS**

### **GENERAL**

*THIS SECTION CONTAINS A SUMMARY OF OUR STUDY AND FINDINGS FOR THE PURPOSES OF A GENERAL OVERVIEW ONLY. MORE SPECIFIC RECOMMENDATIONS AND CONCLUSIONS ARE CONTAINED IN THE REMAINDER OF THIS REPORT. ANY PARTY RELYING ON THIS REPORT SHOULD READ THE ENTIRE DOCUMENT.*

The test borings conducted for this study encountered loose fill and colluvium beneath the ground surface. Very stiff, non-colluvial silt was not encountered until a depth of approximately 42 feet in the test borings located near the proposed residence. Because of the depth of the loose fill and colluvium, as well as the existence of steep slopes near the proposed residence location, several significant structural measures are needed to provide a stable condition for the residence. These include deep foundations, an underground "stabilization wall" on the eastern side of the residence, and a "catchment wall" on the western side of the development.

Any new foundations constructed atop the loose, unconsolidated fill soil and colluvium would result in excessive post-construction settlement, and thus all new foundation loads need to bear on, or into the suitable bearing soils. Due to the depth of the upper loose soils, the excavations needed to reach competent soils is essentially impossible to achieve. Therefore, we recommend that the new residence be supported on deep foundations that are embedded into the very stiff soil. This includes any building floors, or settlement sensitive elements, such as entryways, stairways, or site walls. For all or most of the residence, the deep foundations system could consist of small diameter pipe piles that are driven to refusal in the underlying dense soil. An expanded discussion can be found in the **Pipe Piles** section of this report. However, as discussed in the following paragraph, a concrete-pile stabilization wall is needed on the eastern edge of the residence, and those piles can also be used to support foundation loads.

As previously discussed, the subject site is located within a Potential Landslide Hazard area that encompasses much of the general vicinity. Because of the existence of the upper loose soils and the existence of steep slopes, as well as the results of our slope stability analysis, there is a potential of a landslide in the area of the proposed residence (especially during a Maximum Considered Earthquake (MCE)). Because of this, a "stabilization wall" is needed on the downslope, eastern side of the proposed residence, which will deter movement of the residence down to the east (the downslope side of the residence). Due to the depth of the loose fill and colluvial soils

encountered in our borings, which need to be retained below the ground surface in order to deter movement, the stabilization wall should consist of closely-spaced, heavily-reinforced drilled concrete piles that will embed significantly into the underlying, very stiff, non-colluvial silt; some lateral anchors will also need to be included in the stabilization wall. The wall will need to run along the entire eastern perimeter of the residence. Further discussion regarding the stabilization wall can be found in the **Stabilization Wall** section of this report. If desired, the eastern foundation wall of the residence could be supported on the drilled piles. We strongly recommend that a specialty drilling contractor be contacted early in the design of this wall to help determine costs associated with this wall, as well as explain the challenges and difficulties related to installing a wall system of this magnitude in the onsite soils.

As mentioned previously, the slopes on, and near the site have experienced instability in the past, both related to historic, large-scale, deep-seated movement, and shallower, localized instabilities. Although the stabilization wall will protect the residence against deep-seated slope movement, there is also a possibility of shallow landslides on the steep slope that is upslope/west of the residence area. Due to the relatively limited runout distance between the toe of the slope and perimeter of the yard, a shallow landslide could cause landslide soil/debris to reach the western yard and western side of the residence. Thus, some form of above-grade landslide protection is needed. This above-grade wall will need to be designed to withstand theoretical impact loads from such a debris flow. If a landslide ever were to reach the catchment wall, it is important that the debris be removed as soon as possible in order to restore the catchment area. Additional discussions and design recommendations can be found in the **Landslide Catchment Wall** section of this report.

As discussed below in the **Critical Area Study** section, the recommendations presented in this report are intended to prevent adverse impacts to the stability of the slope onsite, protect the planned development from damage in the event of future instability, and prevent the development from adversely affecting the stability of surrounding properties. It should be noted that the proposed stabilization wall will not increase the surficial stability of the slopes both east and west of the development area outside of transferring the weight of the new residence through the potentially unstable soils down to a competent soil strata. The future property owners should be made well aware that there always exists at least some risk with owning property on, or near steep slopes.

Depending on final foundation elevations, the basement for the new residence may be excavated into soil with a low permeability. Due to the presence of perched groundwater in our borings, some of which were encountered at a relatively shallow depth, we recommend installing an underslab drainage system beneath any basement slab of the new residence. This system would consist of a layer of clean crushed rock beneath the interior slab or crawlspace. The rock layer should be at least 12 inches thick and contain 4-inch diameter, perforated PVC pipes at no more than 15-foot center-to-center spacings. The entire rock layer and pipe system should be covered with a thick vapor retarder/barrier. The perforated pipes should tie into the exterior footing drains. The **Drainage Considerations** section of this report contains an expanded discussion of our subsurface drainage recommendations. We furthermore recommend that, especially if deeper below grade spaces are to be constructed beneath the residence, that a robust waterproofing system be installed in tandem with the surface and subsurface drainage systems. If needed, a specialty building envelope or waterproofing consultant could be contacted during design.

The excavated soil will be unusable as fill for the project and should be hauled off the site. No soil generated from the project excavation or new structural fill should be placed on, or near the steep slope, as the surcharge from the additional soils could reduce the stability of the slope. No water should be directed towards the steep slope along the western side of the development. Poorly

managed stormwater runoff is a common cause of slope instability that is well documented in the Puget Sound area.

Due to the silty, fine-grained nature of the upper fill and native soils onsite, the steep inclination of the slope to the east of the proposed residence, and the Potential Landslide Hazard, it is our professional opinion that onsite infiltration or dispersion of stormwater is not feasible for this project. All collected stormwater, even from paved surfaces, should be discharged to an approved stormwater system. Pervious pavements should not be used for this project.

While the site is mapped as an Erosion Hazard Area, the potential for adverse erosion problems can be mitigated by properly implemented erosion control measures. The erosion control measures needed during the site development will depend heavily on the weather conditions that are encountered. We anticipate that a silt fence will be needed around the downslope sides of any cleared areas. Existing pavements, ground cover, and landscaping should be left in place wherever possible to minimize the amount of exposed soil. Rocked staging areas and construction access roads should be provided to reduce the amount of soil or mud carried off the property by trucks and equipment. Trucks should not be allowed to drive off of the rock-covered areas. Cut slopes and soil stockpiles should be covered with plastic during wet weather. Following clearing or rough grading, it may be necessary to mulch or hydroseed bare areas that will not be immediately covered with landscaping or an impervious surface. On most construction projects, it is necessary to periodically maintain or modify temporary erosion control measures to address specific site and weather conditions.

The drainage and waterproofing recommendations presented in this report are intended only to prevent active seepage from flowing through concrete walls or slabs. Even in the absence of active seepage into and beneath structures, water vapor can migrate through walls, slabs, and floors from the surrounding soil, and can even be transmitted from slabs and foundation walls due to the concrete curing process. Water vapor also results from occupant uses, such as cooking, cleaning, and bathing. Excessive water vapor trapped within structures can result in a variety of undesirable conditions, including, but not limited to, moisture problems with flooring systems, excessively moist air within occupied areas, and the growth of molds, fungi, and other biological organisms that may be harmful to the health of the occupants. The designer or architect must consider the potential vapor sources and likely occupant uses, and provide sufficient ventilation, either passive or mechanical, to prevent a buildup of excessive water vapor within the planned structure.

Geotech Consultants, Inc. should be allowed to review the final development plans to verify that the recommendations presented in this report are adequately addressed in the design. Such a plan review would be additional work beyond the current scope of work for this study, and it may include revisions to our recommendations to accommodate site, development, and geotechnical constraints that become more evident during the review process.

We recommend including this report, in its entirety, in the project contract documents. This report should also be provided to any future property owners so they will be aware of our findings and recommendations.

### **CRITICAL AREA STUDY (MICC 19.07)**

**Potential Landslide Hazard Area:** The entire site is located within a mapped Potential Landslide Hazard area.

The Potential Slide Area mapping covers much of the general vicinity. The core of the subject site consists of very stiff native soil that has a low potential for deep-seated landslides. However, this competent soil is overlain by a relatively deep layer of loose fill and loose and medium-dense colluvial soils that could experience slope movement, particularly during a large earthquake.

The new residence will be supported on deep foundations that will be supported on the underlying non-colluvial silt soils. Also, the recommendations presented in this report are intended to stabilize the new development area in the event of slope instability with the use of a stabilization wall and a catchment wall, thereby mitigating the Potential Landslide Hazard risk. Information regarding deep foundations, a stabilization wall, and a catchment wall are discussed further in following sections, will also prevent the planned development from being adversely affected by a potential landslide(s) and also from adversely impacting the stability of the neighboring properties. No buffers are necessary to mitigate the mapped Potential Landslide Hazard because of the inclusion of these measures.

**Seismic Hazard:** The site is mapped as a Seismic Hazard Area. The Seismic Hazard mapping appears to be related to the presence of the watercourse, as well as mapping information provided by *Mercer Island's Landslide Hazard Assessment Map*.

The planned development will occur within this mapped Seismic Hazard area. The loose, wet sand soils underlying the planned residence are potentially liquefiable during a large earthquake due to their density and the presence of perched groundwater. All of the foundations for the new residence will be supported on deep foundations installed into the underlying, non-liquefiable soils. No further measures are needed to mitigate the mapped Seismic Hazard.

**Steep Slope Hazard Areas:** The slopes located both east and west of the proposed residence meet the MICC criteria for Steep Slope Hazard areas. The inclusion of deep foundation support for the residence, catchment wall west of the development, and stabilization wall on the east side of the residence are intended to provide stability to the project in case of potential slope movement. Therefore, it is our opinion that the proposed residence can be constructed in its proposed location, and no additional buffers or setbacks are needed from the Steep Slope areas on, or adjoining the site, provided the recommendations presented in this report are followed. The recommendations presented in the report are intended to prevent adverse impacts to the stability of the Steep Slopes, and to protect the planned development from foreseeable future soil movement on the slopes.

**Erosion Hazard Area:** The site also meets the City of Mercer Island's criteria for an Erosion Hazard Area. Excavation and construction of the planned residence can be accomplished without adverse erosion impacts to the site and surrounding properties by exercising care and being proactive with the maintenance and potential upgrading of the erosion control system through the entire construction process. Proper erosion control implementation will be important to prevent adverse impacts to the site and neighboring properties, particularly if grading and construction occurs during the wet season. The temporary erosion control measures needed during the site development will depend heavily on the weather conditions that are encountered during the site work. One of the most important considerations, particularly during wet weather, is to immediately cover any bare soil areas to prevent accumulated water or runoff from the work area from becoming silty in the first place. Silty water cannot be discharged off the site, so a temporary holding tank

should be planned for wet weather earthwork, and specialty permits may be needed to discharge collected water. A wire-backed silt fence bedded in compost, not native soil, or sand, should be erected as close as possible to the planned work area, and the existing vegetation outside of the perimeter of the silt fence should be left in place. Rocked construction access and staging areas should be established wherever trucks will have to drive off of pavement, in order reduce the amount of soil or mud carried off the property by trucks and equipment. Covering the base of the excavation with a layer of clean gravel or rock is also prudent to reduce the amount of mud and silty water generated. Cut slopes and soil stockpiles should be covered with plastic during wet weather. Soil stockpiles should be minimized. Silty water accumulating in the excavation must not be allowed to flow off the site. In wet conditions, this can require the use of temporary holding tanks (aka Baker tanks). Following rough grading, it may be necessary to mulch or hydroseed bare areas that will not be immediately covered with landscaping or an impervious surface.

**Buffers and Mitigation:** Under MICC 19.07.160(C), the code-prescriptive buffer of 25 feet is indicated from all sides of a shallow landslide-hazard area. As noted above, the majority of the site lies within a mapped Potential Landslide Hazard area, and the prescriptive buffer would extend far beyond the boundaries of the property and the planned development area.

We recognize that the planned development will occur within the designated critical areas and their applicable prescriptive buffers. The recommendations presented in this geotechnical report are intended to allow the project to be constructed in the proposed configuration without the need for a buffer from the top of the steep slope. Following the recommendations of this report, the planned development will not be adversely affected by potential soil movement as has been discussed in this report. In addition, the development will not impact the stability of the neighboring properties or result in a need for increased critical area buffers on those adjacent properties. The geotechnical recommendations associated with foundations, shoring, and erosion control will mitigate any potential hazards to geologic critical areas on the site.

**Statement of Risk:** In order to satisfy the City of Mercer Island's requirements, a statement of risk is needed. As such, we make the following statement:

*The development has been designed so that the risk to the lot and adjacent property is mitigated such that the site is determined to be safe.*

## **PIPE PILES**

Four- or six-inch-diameter pipe piles driven with 1,100-, 2,000-pound, or 3,000-pound hydraulic jackhammer to the following final penetration rates may be assigned the following compressive capacities.

<b>INSIDE PILE DIAMETER</b>	<b>FINAL DRIVING RATE (1,100-pound hammer)</b>	<b>FINAL DRIVING RATE (2,000-pound hammer)</b>	<b>FINAL DRIVING RATE (3,000-pound hammer)</b>	<b>ALLOWABLE COMPRESSIVE CAPACITY</b>
4 inches	10 sec/inch	4 sec/inch	n/a	8 tons
6 inches	20 sec/inch	10 sec/inch	6 sec/inch	16 tons

**Note:** The refusal criteria indicated in the above table are valid only for pipe piles that are installed using a hydraulic impact hammer carried on leads that allow the hammer to sit on the top of the pile during driving. If the piles are installed by alternative methods, such as a vibratory hammer or a hammer that is hard-mounted to the installation machine, numerous load tests to 200 percent of the design capacity would be necessary to substantiate the allowable pile load. The appropriate number of load tests would need to be determined at the time the contractor and installation method are chosen.

As a minimum, Schedule 40 pipe should be used. The site soils contain organics and will be driven into wet soils. As a result, they have an elevated corrosion potential. Considering this, it is our opinion that corrosion protection, such as galvanizing, should be used for the pipe piles on this project.

Mercer Island has adopted Seattle Director's Rule 10-2009 in recent years. Seattle Director's Rule 10-2009 contains several prescriptive requirements related to the use of pipe piles having a diameter of less than 10 inches. Under Director's Rule 10-2009, load tests are required on 3 percent of the installed piles up to a maximum of 5 piles, with a minimum of one pile load test on each project. Additionally, full-time observation of the pile installation by the geotechnical engineer-of-record is required by Director's Rule 10-2009.

Pile caps and grade beams should be used to transmit loads to the piles. Isolated pile caps should include a minimum of two piles to reduce the potential for eccentric loads being applied to the piles. Subsequent sections of pipe can be connected with slip or threaded couplers, or they can be welded together. If slip couplers are used, they should fit snugly into the pipe sections. This may require that shims be used or that beads of welding flux be applied to the outside of the coupler.

Lateral loads due to wind or seismic forces may be resisted by passive earth pressure acting on the vertical, embedded portions of the foundation. For this condition, the foundation must be either poured directly against relatively level, undisturbed soil or be surrounded by level compacted fill. We recommend using a passive earth pressure of 250 pounds per cubic foot (pcf) for this resistance. This is an ultimate value that does not include a safety factor. If the ground in front of a foundation is loose or sloping, the passive earth pressure given above will not be appropriate.

Due to their small diameter, the lateral capacity of vertical pipe piles is relatively small. However, if lateral resistance in addition to passive soil resistance is required, we recommend driving battered piles in the same direction as the applied lateral load. The lateral capacity of a battered pile is equal to one-half of the lateral component of the allowable compressive load. The allowable vertical

capacity of battered piles does not need to be reduced if the piles are battered steeper than 1:5 (Horizontal:Vertical).

We recommend a minimum pile length of 40 feet below the existing ground surface. However, our experience with installation of small-diameter pipe piles indicates that it is likely that they will be longer than this minimum length to reach refusal.

## **STABILIZATION WALL**

Plate 14 depicts a typical design detail for the closely-spaced, reinforced concrete piles that will stabilize the residence against potential movement of the loose fill and colluvium; it should be located on the eastern side of the residence. This wall is essentially a heavily-reinforced, below-grade, permanent soldier pile wall that will act to retain these loose soils in the residence envelope in the event of a potential future landslide. The piles should be spaced at no more than 3 feet edge-to-edge to allow soil to arch between the piles in the event that they are exposed by a future slide on the ground downslope of the site; no lagging between the piles is needed. However, if the wall is exposed by slope movement in the future, it would be necessary to install timber lagging behind the piles.

Based on the results of our slope stability analysis, we recommend that the stabilization wall be designed for a retention height of 45 feet, as measured from the existing grade. This retention height may need to be modified depending on finish grades.

Drilled piles would be constructed by setting steel H-beams or rebar cages in drilled holes and grouting the spaces between the steel reinforcements and the soil with concrete for the entire height of the hole. Based on the perched water and loose soils encountered in our borings, we anticipate that the piles will either need to be installed using casing, drilling slurry, or using Continuous Flight Auger (CFA) drilling methods. The specialty drilling contractor should be well prepared with a method to maintain shaft integrity during drilling if wet or caving soils are encountered. We also anticipate that tremie pipes will be needed to pump concrete into the holes if non-CFA methods are utilized. Excessive ground loss in the drilled holes must be avoided to reduce the potential for settlement of adjacent structures. If water is present in a hole at the time of construction, concrete must be tremied to the bottom of the hole.

The stabilization wall should be designed for an active soil pressure equal to that pressure exerted by an equivalent fluid with a unit weight of 45 pcf if it retains level backfill. This active pressure acts on the pile spacing within the retained height (H), and on the pile diameter within the embedment zone (D). An ultimate (no safety factor included) passive soil pressure equal to that pressure exerted by a fluid with a density of 400 pcf will resist the lateral movement of the piles below the stabilization depth. This passive pressure acts on two times the pile diameter, or the pile spacing, whichever is less. For long term conditions, a safety factor of 1.5 should be applied to the lateral design of this stabilization wall.

The concrete piles can also be used for support of vertical loads imposed by the residence structure. An allowable adhesion of 1,000 psf can be attributed to the embedded portion of the piles below the retained height if the western edge of the residence is to be supported by the piles.

As noted earlier, it is extremely likely that additional lateral stability is needed for the stabilization wall in addition to the stability provided by the concrete piles. Grouted tieback anchors are a very

appropriate measure to provide additional lateral stability. Information regarding tieback anchors is as follows:

Depending on the structural design, tieback anchors may be needed to supplement the lateral design of the stabilization wall, as well as the landslide catchment wall. These conceptual tieback anchors are shown on the attached Plate 14 for reference. We recommend installing tieback anchors at inclinations between 20 and 30 degrees below horizontal, but steeper inclinations could be explored in an attempt to shorten anchor lengths. The tieback will derive its capacity from the soil-grout strength developed in the non-colluvial soils encountered at relatively great depths beneath the site. The minimum grouted anchor length should be 50 feet, but anchor lengths will likely need to be longer to achieve sufficient embedment into the underlying very stiff silts. Based on the surface elevations of our deeper boring located behind the existing residence (approximate surface elevation of 146 feet), the very stiff, non-colluvial soils were encountered at approximate elevation 104 feet beneath the residence. The no-load zone is the area behind which the entire length of each tieback anchor should be located. To prevent excessive loss-of-ground in a drilled hole, the no-load section of the drilled tieback hole should be backfilled with a sand and fly ash slurry, after protecting the anchor with a bond breaker, such as plastic casing, to prevent loads from being transferred to the soil in the no-load zone. The no-load section could be filled with grout after anchor testing is completed.

Based on the results of our analyses and our experience at other construction sites, we suggest using an adhesion value of 1,250 psf in the very stiff silt to design anchors if the mid-point of the grouted portion of the anchor is more than 40 feet below the overlying ground surface. This value applies to non-pressure-grouted anchors. Pressure-grouted or post-grouted anchors can often develop adhesion values that are two to three times higher than that for non-pressure-grouted anchors. These higher adhesion values must be verified by load testing.

Soil conditions, soil-grout adhesion strengths, and installation techniques typically vary over any site. This sometimes results in adhesion values that are lower than anticipated. Therefore, we recommend substantiating the anchor design values by load-testing all tieback anchors. At least two anchors in each soil type encountered should be performance-tested to 200 percent of the design anchor load to evaluate possible anchor creep. Wherever possible, the no-load section of these tiebacks should not be grouted until the performance tests are completed. Unfavorable results from these performance tests could require increasing the lengths of the tiebacks. The remaining anchors should be proof-tested to at least 135 percent of their design value before being "locked off." After testing, each anchor should be locked off at a prestress load of 80 to 100 percent of its design load.

If caving or water-bearing soil is encountered, the installation of tieback anchors will be hampered by caving and soil flowing into the holes. It will be necessary to case the holes if such conditions are encountered. Alternatively, the use of a hollow-stem auger with grout pumped through the stem as the auger is withdrawn would be satisfactory, provided that the injection pressure and grout volumes pumped are carefully monitored. Based on the soil and water conditions encountered in our borings, we anticipate that the tiebacks would need to be drilled using full length casing to maintain hole integrity.

All drilled installations should be grouted and backfilled immediately after drilling. No drilled holes should be left open overnight.

## **LANDSLIDE CATCHMENT WALL**

There is a potential for landslides to occur on the slope to the west of the development area, especially during or following times of excessive precipitation or an earthquake. It has been common to mitigate the potential of the hazard of landslides in this area by constructing a reinforced retaining (catchment) wall on the side of developments that area exposed to steep slopes. Such a wall would extend above the level of the development.

The height of the above-grade portion of this catchment wall will vary depending on the final location of the wall with respect to the toe of the slope. For this report, two scenarios were analyzed for preliminary considerations: 1) If the wall is to be located at the toe of the western slope, which is the approximate western edge of the existing yard, we recommend that a minimum catchment height of 7 feet be included in the design of this wall, 2) If the wall is sited at least 15 feet from the toe of the western slope, a reduced catchment height of 5 feet would be needed due to the additional runout area between the toe of the slope and wall. This will catch small slides, and slow larger slides. An active equivalent fluid pressure of 100 pounds per cubic foot (pcf) should be used in the design of the catchment portion of this wall to account for an impact force. It may be necessary to remove accumulated material periodically. The removal of small amounts of material could be accomplished by hand or using small equipment. The freeboard of the catchment wall must be maintained for the wall to provide continued protection from landslides.

Due to the poor soil conditions encountered in our borings, this catchment wall will need to be supported on deep foundations. We have provided recommendations for pipe piles, but depending on the structural design, larger diameter piles or lateral anchors such as anchor tiebacks may be needed to withstand the lateral forces that this wall will need to be designed for. We can comment on this as the project design progresses.

## **FOUNDATION AND RETAINING WALLS**

Retaining walls backfilled on only one side should be designed to resist the lateral earth pressures imposed by the soil they retain. The following recommended parameters are for walls that restrain level backfill:

<b>PARAMETER</b>	<b>VALUE</b>
Lateral Earth Pressure *	40 pcf
Passive Earth Pressure	300 pcf
Soil Unit Weight	130 pcf

Where: pcf is Pounds per Cubic Foot, and Lateral and Passive Earth Pressures are computed using the Equivalent Fluid Pressures.

\* For a restrained wall that cannot deflect at least 0.002 times its height, a uniform lateral pressure equal to 10 psf times the height of the wall should be added to the above lateral equivalent fluid pressure. This applies only to walls with level backfill.

The design values given above do not include the effects of any hydrostatic pressures behind the walls and assume that no surcharges, such as those caused by slopes, vehicles, or adjacent foundations will be exerted on the walls. If these conditions exist, those pressures should be added to the above lateral soil pressures. Where sloping backfill is desired behind the walls, we will need to be given the wall dimensions and the slope of the backfill in order to provide the appropriate

design earth pressures. The surcharge due to traffic loads behind a wall can typically be accounted for by adding a uniform pressure equal to 2 feet multiplied by the above lateral fluid density. Heavy construction equipment should not be operated behind retaining and foundation walls within a distance equal to the height of a wall, unless the walls are designed for the additional lateral pressures resulting from the equipment.

The values given above are to be used to design only permanent foundation and retaining walls that are to be backfilled, such as conventional walls constructed of reinforced concrete or masonry. It is not appropriate to use the above earth pressures and soil unit weight to back-calculate soil strength parameters for design of other types of retaining walls, such as soldier pile, reinforced earth, modular or soil nail walls. We can assist with the design of these types of walls, if desired.

The passive pressure given is appropriate only for the depth of level, well-compacted fill placed in front of a retaining or foundation wall. The values for friction and passive resistance are ultimate values and do not include a safety factor. Restrained wall soil parameters should be utilized the wall and reinforcing design for a distance of 1.5 times the wall height from corners or bends in the walls, or from other points of restraint. This is intended to reduce the amount of cracking that can occur where a wall is restrained by a corner.

### **Wall Pressures Due to Seismic Forces**

Per IBC Section 1803.5.12, a seismic surcharge load need only be considered in the design of walls over 6 feet in height. A seismic surcharge load would be imposed by adding a uniform lateral pressure to the above-recommended lateral pressure. The recommended seismic surcharge pressure for this project is  $9H$  pounds per square foot (psf), where  $H$  is the design retention height of the wall. Using this increased pressure, the safety factor against sliding and overturning can be reduced to 1.2 for the seismic analysis.

### **Retaining Wall Backfill and Waterproofing**

Backfill placed behind retaining or foundation walls should be coarse, free-draining structural fill containing no organics. This backfill should contain no more than 5 percent silt or clay particles and have no gravel greater than 4 inches in diameter. The percentage of particles passing the No. 4 sieve should be between 25 and 70 percent. In addition, a drainage composite similar to Miradrain 6000 should be placed against the backfilled retaining walls. The drainage composites should be hydraulically connected to the foundation drain system. Free-draining backfill should be used for the entire width of the backfill where seepage is encountered. The later section entitled ***Drainage Considerations*** should also be reviewed for recommendations related to subsurface drainage behind foundation and retaining walls.

The purpose of these backfill requirements is to ensure that the design criteria for a retaining wall are not exceeded because of a build-up of hydrostatic pressure behind the wall. Also, subsurface drainage systems are not intended to handle large volumes of water from surface runoff. The top 12 to 18 inches of the backfill should consist of a compacted, relatively impermeable soil or topsoil, or the surface should be paved. The ground surface must also slope away from backfilled walls at one to 2 percent to reduce the potential for surface water to percolate into the backfill.

Water percolating through pervious surfaces (pavers, gravel, permeable pavement, etc.) must also be prevented from flowing toward walls or into the backfill zone. Foundation drainage and waterproofing systems are not intended to handle large volumes of infiltrated

water. The compacted subgrade below pervious surfaces and any associated drainage layer should therefore be sloped away. Alternatively, a membrane and subsurface collection system could be provided below a pervious surface.

It is critical that the wall backfill be placed in lifts and be properly compacted, in order for the above-recommended design earth pressures to be appropriate. The recommended wall design criteria assume that the backfill will be well-compacted in lifts no thicker than 12 inches. The compaction of backfill near the walls should be accomplished with hand-operated equipment to prevent the walls from being overloaded by the higher soil forces that occur during compaction. The section entitled **General Earthwork and Structural Fill** contains additional recommendations regarding the placement and compaction of structural fill behind retaining and foundation walls.

The above recommendations are not intended to waterproof below-grade walls, or to prevent the formation of mold, mildew, or fungi in interior spaces. Over time, the performance of subsurface drainage systems can degrade, subsurface groundwater flow patterns can change, and utilities can break or develop leaks. Therefore, waterproofing should be provided where future seepage through the walls is not acceptable. This typically includes limiting cold-joints and wall penetrations and using bentonite panels or membranes on the outside of the walls. There are a variety of different waterproofing materials and systems, which should be installed by an experienced contractor familiar with the anticipated construction and subsurface conditions. Applying a thin coat of asphalt emulsion to the outside face of a wall is not considered waterproofing and will only help to reduce moisture generated from water vapor or capillary action from seeping through the concrete. As with any project, adequate ventilation of basement and crawl space areas is important to prevent a buildup of water vapor that is commonly transmitted through concrete walls from the surrounding soil, even when seepage is not present. This is appropriate even when waterproofing is applied to the outside of foundation and retaining walls. We recommend that you contact an experienced envelope consultant if detailed recommendations or specifications related to waterproofing design, or minimizing the potential for infestations of mold and mildew are desired.

## **BUILDING FLOORS**

The building floors should be supported by deep foundations with no reliance on soil bearing, either as a structural slab or as a framed floor atop a crawlspace.

Even where the exposed soils appear dry, water vapor will tend to naturally migrate upward through the soil to the newly constructed space above it. This can affect moisture-sensitive flooring, cause imperfections or damage to the slab, or simply allow excessive water vapor into the space above the slab. All interior slabs-on-grade should be underlain by a capillary break drainage layer consisting of a minimum 4-inch thickness of clean gravel or crushed rock that has a fines content (percent passing the No. 200 sieve) of less than 3 percent and a sand content (percent passing the No. 4 sieve) of no more than 10 percent. Pea gravel or crushed rock are typically used for this layer.

As noted by the American Concrete Institute (ACI) in the *Guides for Concrete Floor and Slab Structures*, proper moisture protection is desirable immediately below any on-grade slab that will be covered by tile, wood, carpet, impermeable floor coverings, or any moisture-sensitive equipment or products. ACI recommends a minimum 10-mil thickness vapor retarder for better durability and long term performance than is provided by 6-mil plastic sheeting that has historically been used. A vapor

retarder is defined as a material with a permeance of less than 0.3 perms, as determined by ASTM E 96. It is possible that concrete admixtures may meet this specification, although the manufacturers of the admixtures should be consulted. Where vapor retarders are used under slabs, their edges should overlap by at least 6 inches and be sealed with adhesive tape. The sheeting should extend to the foundation walls for maximum vapor protection.

If no potential for vapor passage through the slab is desired, a vapor *barrier* should be used. A vapor barrier, as defined by ACI, is a product with a water transmission rate of 0.01 perms when tested in accordance with ASTM E 96. Reinforced membranes having sealed overlaps can meet this requirement.

We recommend that the contractor, the project materials engineer, and the owner discuss these issues and review recent ACI literature and ASTM E-1643 for installation guidelines and guidance on the use of the protection/blotter material.

### **EXCAVATIONS AND SLOPES**

Temporary excavation slopes should not exceed the limits specified in local, state, and national government safety regulations. Also, temporary cuts should be planned to provide a minimum 2 to 3 feet of space for construction of foundations, walls, and drainage. Temporary cuts to a maximum overall depth of about 4 feet may be attempted vertically in unsaturated soil if there are no indications of slope instability. However, vertical cuts should not be made near property boundaries, near existing utilities and structures, or at the base of sloped cuts. Based upon Washington Administrative Code (WAC) 296, Part N, the soil at the subject site located above the wet soils encountered in our borings would generally be classified as Type C. Therefore, temporary cut slopes greater than 4 feet in height should not be excavated at an inclination steeper than 1.5:1 (Horizontal:Vertical), extending continuously between the top and the bottom of a cut.

The above-recommended temporary slope inclination is based on the conditions exposed in our explorations, and on what has been successful at other sites with similar soil conditions. It is possible that variations in soil and groundwater conditions will require modifications to the inclination at which temporary slopes can stand. Temporary cuts are those that will remain unsupported for a relatively short duration to allow for the construction of foundations, retaining walls, or utilities. Temporary cut slopes should be protected with plastic sheeting during wet weather. It is also important that surface runoff be directed away from the top of temporary slope cuts. Cut slopes should also be backfilled or retained as soon as possible to reduce the potential for instability. Please note that loose soil can cave suddenly and without warning. Excavation, foundation, and utility contractors should be made especially aware of this potential danger. These recommendations may need to be modified if the area near the potential cuts has been disturbed in the past by utility installation, or if settlement-sensitive utilities are located nearby.

All permanent cuts into native soil and any compacted fill slope should be inclined no steeper than 2.5:1 (H:V). To reduce the potential for shallow sloughing, fill must be compacted to the face of these slopes. This can be accomplished by overbuilding the compacted fill and then trimming it back to its final inclination. Adequate compaction of the slope face is important for long-term stability and is necessary to prevent excessive settlement of patios, slabs, foundations, or other improvements that may be placed near the edge of the slope.

Water should not be allowed to flow uncontrolled over the top of any temporary or permanent slope. All permanently exposed slopes should be seeded with an appropriate species of vegetation to reduce erosion and improve the stability of the surficial layer of soil.

Any disturbance to the existing slope outside of the building limits may reduce the stability of the slope. Damage to the existing vegetation and ground should be minimized, and any disturbed areas should be revegetated as soon as possible. Soil from the excavation should not be placed on the slope, and this may require the off-site disposal of any surplus soil.

## **DRAINAGE CONSIDERATIONS**

Footing drains should be used where: (1) crawl spaces or basements will be below a structure; (2) a slab is below the outside grade; or (3) the outside grade does not slope downward from a building. Drains should also be placed at the base of all earth-retaining walls. These drains should be surrounded by at least 6 inches of 1-inch-minus, washed rock that is encircled with non-woven, geotextile filter fabric (Mirafi 140N, Supac 4NP, or similar material). At its highest point, a perforated pipe invert should be at least 6 inches below the bottom of a slab floor or the level of a crawl space. The discharge pipe for subsurface drains should be sloped to flow to the outlet point. Roof and surface water drains must not discharge into the foundation drain system. A typical footing drain detail is attached to this report as Plate 15. For the best long-term performance, perforated PVC pipe is recommended for all subsurface drains. Clean-outs should be provided for potential future flushing or cleaning of footing drains. As noted in the **General** section, underslab drainage should be used if there is a basement in the residence. A typical underslab drainage detail has been attached to this report as Plate 16.

If the structure includes an elevator, it may be necessary to provide special drainage or waterproofing measures for the elevator pit. If no seepage into the elevator pit is acceptable, it will be necessary to provide a footing drain and free-draining wall backfill, and the walls should be waterproofed. If the footing drain is too low to connect to the storm drainage system, then it will likely be necessary to install a pumped sump to discharge the collected water. Alternatively, the elevator pit could be designed to be entirely waterproof; this would include designing the pit structure to resist hydrostatic uplift pressures.

As a minimum, a vapor retarder, as defined in the **Slabs-On-Grade** section, should be provided in any crawl space area to limit the transmission of water vapor from the underlying soils. Crawl space grades are sometimes left near the elevation of the bottom of the footings. As a result, an outlet drain is recommended for all crawl spaces to prevent an accumulation of any water that may bypass the footing drains. Providing a few inches of free draining gravel underneath the vapor retarder is also prudent to limit the potential for seepage to build up on top of the vapor retarder.

Perched groundwater was observed during our field work. If seepage is encountered in an excavation, it should be drained from the site by directing it through drainage ditches, perforated pipe, or French drains, or by pumping it from sumps interconnected by shallow connector trenches at the bottom of the excavation.

The excavation and site should be graded so that surface water is directed off the site and away from the tops of slopes. Water should not be allowed to stand in any area where foundations, slabs, or pavements are to be constructed. Final site grading in areas adjacent to the residence should slope away at least one to 2 percent, except where the area is paved. Surface drains should be provided where necessary to prevent ponding of water behind foundation or retaining walls. A

discussion of grading and drainage related to pervious surfaces near walls and structures is contained in the **Foundation and Retaining Walls** section.

### **GENERAL EARTHWORK AND STRUCTURAL FILL**

All building and pavement areas should be stripped of surface vegetation, topsoil, organic soil, and other deleterious material. The stripped or removed materials should not be mixed with any materials to be used as structural fill, but they could be used in non-structural areas, such as landscape beds.

Structural fill is defined as any fill, including utility backfill, placed under, or close to, a building, or in other areas where the underlying soil needs to support loads. All structural fill should be placed in horizontal lifts with a moisture content at, or near, the optimum moisture content. The optimum moisture content is that moisture content that results in the greatest compacted dry density. The moisture content of fill is very important and must be closely controlled during the filling and compaction process. Onsite soils are not suitable as structural fill.

The allowable thickness of the fill lift will depend on the material type selected, the compaction equipment used, and the number of passes made to compact the lift. The loose lift thickness should not exceed 12 inches, but should be thinner if small, hand-operated compactors are used. We recommend testing structural fill as it is placed. If the fill is not sufficiently compacted, it should be recompacted before another lift is placed. This eliminates the need to remove the fill to achieve the required compaction. The following table presents recommended levels of relative compaction for compacted fill:

<b>LOCATION OF FILL PLACEMENT</b>	<b>MINIMUM RELATIVE COMPACTION</b>
Beneath walkways	92%
Filled slopes and behind retaining walls	92%
Beneath pavements	95% for upper 12 inches of subgrade; 90% below that level

Where: Minimum Relative Compaction is the ratio, expressed in percentages, of the compacted dry density to the maximum dry density, as determined in accordance with ASTM Test Designation D 1557-91 (Modified Proctor).

### **LIMITATIONS**

The conclusions and recommendations contained in this report are based on site conditions as they existed at the time of our exploration and assume that the soil and groundwater conditions encountered in the test borings are representative of subsurface conditions on the site. If the subsurface conditions encountered during construction are significantly different from those observed in our explorations, we should be advised at once so that we can review these conditions and reconsider our recommendations where necessary. Unanticipated conditions are commonly encountered on construction sites and cannot be fully anticipated by merely taking samples in test borings. Subsurface conditions can also vary between exploration locations. Such unexpected conditions frequently require making additional expenditures to attain a properly constructed project. It is recommended that the owner consider providing a contingency fund to accommodate such potential extra costs and risks. This is a standard recommendation for all projects.

The recommendations presented in this report are directed toward the protection of only the proposed residence from damage due to slope movement. Predicting the future behavior of steep slopes and the potential effects of development on their stability is an inexact and imperfect science that is currently based mostly on the past behavior of slopes with similar characteristics. Landslides and soil movement can occur on steep slopes before, during, or after the development of property. The owner of any property containing or located close to steep slopes must ultimately accept the possibility that some slope movement could occur. However, such movement will not affect the residence if the recommendations in this report are followed.

This report has been prepared for the exclusive use of Derek and Eileen Cheshire, and their representatives, for specific application to this project and site. Our conclusions and recommendations are professional opinions derived in accordance with our understanding of current local standards of practice, and within the scope of our services. No warranty is expressed or implied. The scope of our services does not include services related to construction safety precautions, and our recommendations are not intended to direct the contractor's methods, techniques, sequences, or procedures, except as specifically described in our report for consideration in design. Our services also do not include assessing or minimizing the potential for biological hazards, such as mold, bacteria, mildew, and fungi in either the existing or proposed site development.

### **ADDITIONAL SERVICES**

In addition to reviewing the final plans, Geotech Consultants, Inc. should be retained to provide geotechnical consultation, testing, and observation services during construction. This is to confirm that subsurface conditions are consistent with those indicated by our exploration, to evaluate whether earthwork and foundation construction activities comply with the general intent of the recommendations presented in this report, and to provide suggestions for design changes in the event subsurface conditions differ from those anticipated prior to the start of construction. However, our work would not include the supervision or direction of the actual work of the contractor and its employees or agents. Also, job and site safety, and dimensional measurements, will be the responsibility of the contractor.

During the construction phase, we will provide geotechnical observation and testing services when requested by you or your representatives. Please be aware that we can only document sitework we actually observe. It is still the responsibility of your contractor or on-site construction team to verify that our recommendations are being followed, whether we are present at the site or not.

The following plates are attached to complete this report:

Plate 1	Vicinity Map
Plate 2	Site Exploration Plan
Plates 3 - 13	Test Boring Logs
Plate 14	Typical Stabilization Wall Detail
Plate 15	Typical Footing Drain Detail
Plate 16	Typical Underslab Drainage Detail
Appendix A	Slope Stability Analysis

We appreciate the opportunity to be of service on this project. Please contact us if you have any questions, or if we can be of further assistance.

Respectfully submitted,

GEOTECH CONSULTANTS, INC.



9/15/2023

D. Robert Ward, P.E.  
Principal

MKM/DRW:kg

**NORTH**

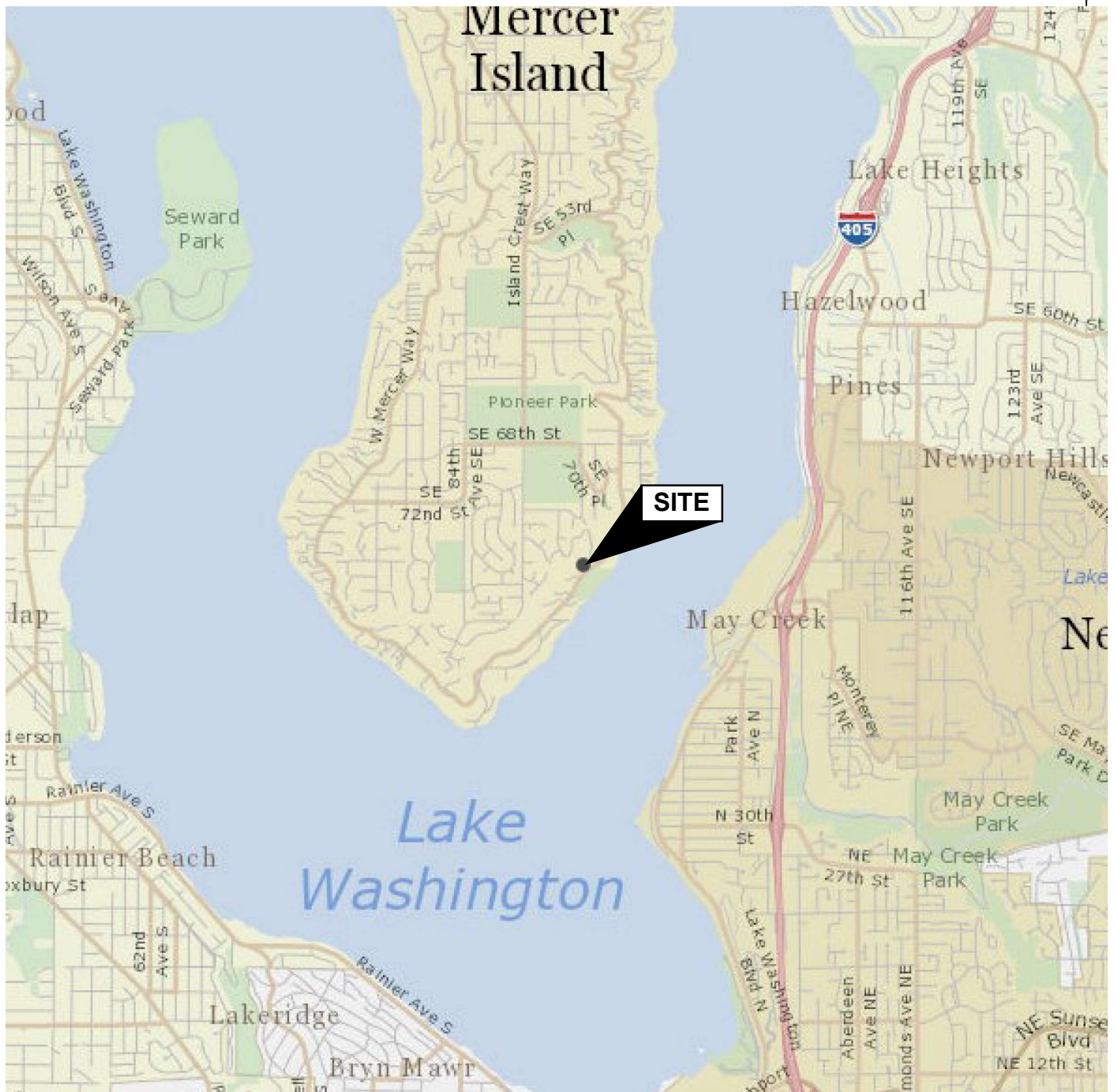
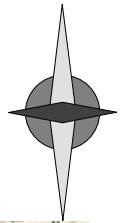

(Source: King County iMap)



**GEOTECH**  
CONSULTANTS, INC.



**VICINITY MAP**  
7615 East Mercer Way  
Mercer Island, Washington

<b>Job No:</b> 23177	<b>Date:</b> June 2023	<b>Plate:</b> 1
-------------------------	---------------------------	--------------------

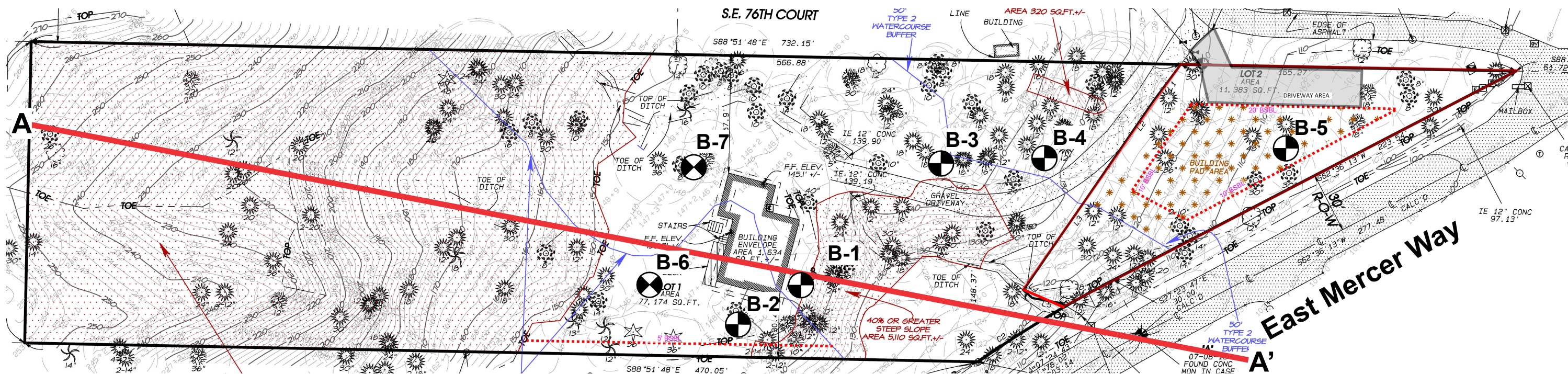
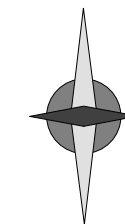
NORTH



**Legend:**

-  Test Boring Location (GCI, 2016)
-  Test Boring Location (GCI, 2023)

A — A' Slope Stability Cross Section



**GEOTECH**  
CONSULTANTS, INC.

**SITE EXPLORATION PLAN**

7615 East Mercer Way  
Mercer Island, Washington

<b>Job No:</b> 23177	<b>Date:</b> Sept. 2023	<b>Plate:</b> 2
-------------------------	----------------------------	--------------------

# BORING 1

Depth (ft.)	Moisture	Water Table	Blows per Foot	Sample	USCS	Description
						Topsoil over;
			9	1	ML	Gray-brown SILT with clay, slightly plastic, moist, stiff
5			13	2		
			13	3		
10			18	4		-becomes medium-dense and non-plastic, reduced clay content
			17	5		
15			21	6		-becomes gray, increased sand content
			18	7		
20						
25						
30						

\* Test boring was terminated at 26.5 feet on March 31, 2016.  
 \* No groundwater was encountered during drilling.



**TEST BORING LOG**  
 7615 East Mercer Way  
 Mercer Island, Washington

<b>Job</b> 16095	<b>Date:</b> March 2016	<b>Logged by:</b> TRC	<b>Plate:</b> 3
---------------------	----------------------------	--------------------------	--------------------

# BORING 2

Depth (ft.)  
Moisture  
Water  
Table  
Blows  
per Foot  
Sample  
USCS

Description

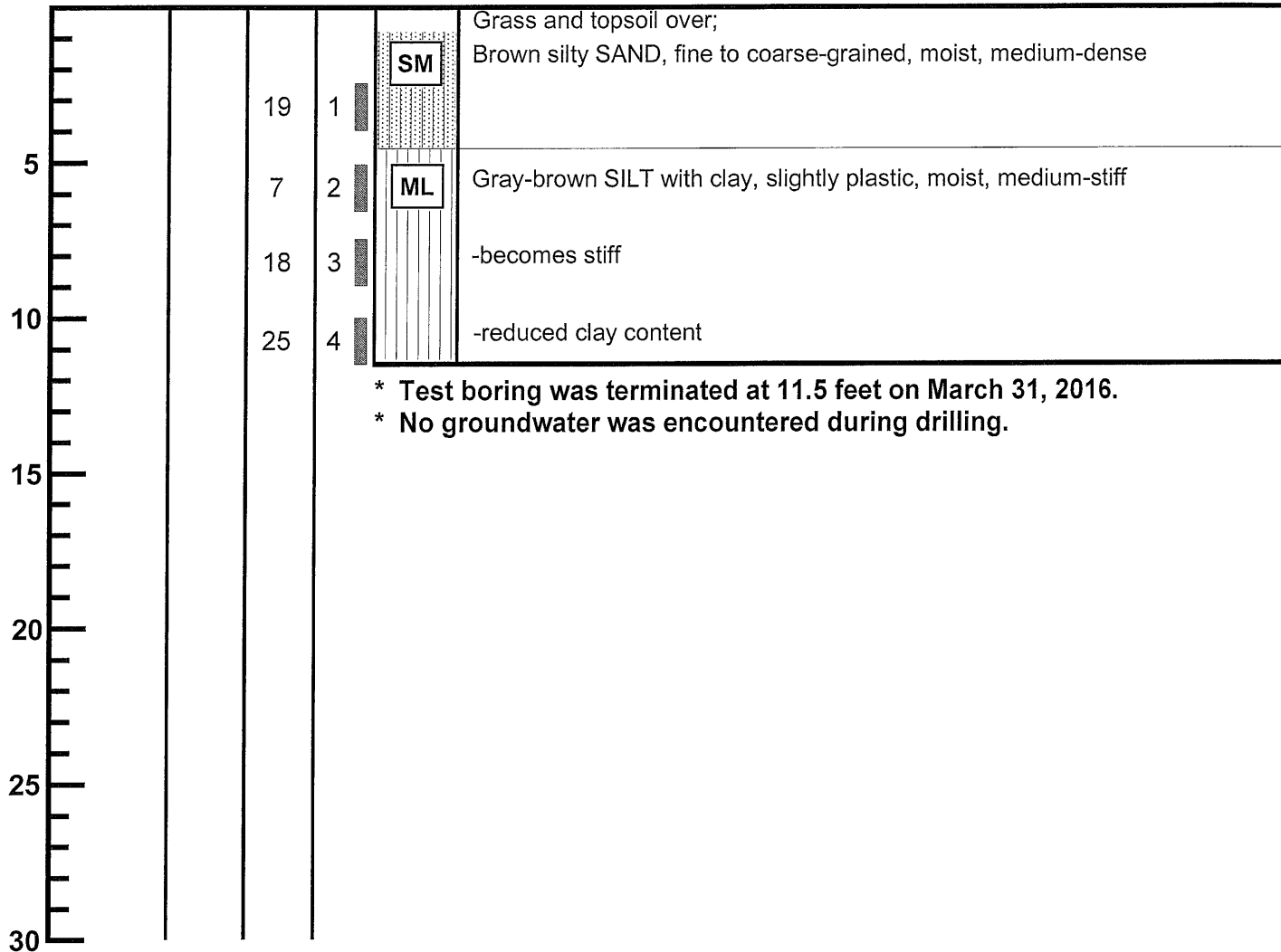

\* Test boring was terminated at 11.5 feet on March 31, 2016.  
\* No groundwater was encountered during drilling.



**TEST BORING LOG**  
7615 East Mercer Way  
Mercer Island, Washington

<b>Job</b> 16095	<b>Date:</b> March 2016	<b>Logged by:</b> TRC	<b>Plate:</b> 4
---------------------	----------------------------	--------------------------	--------------------

# BORING 3

Description

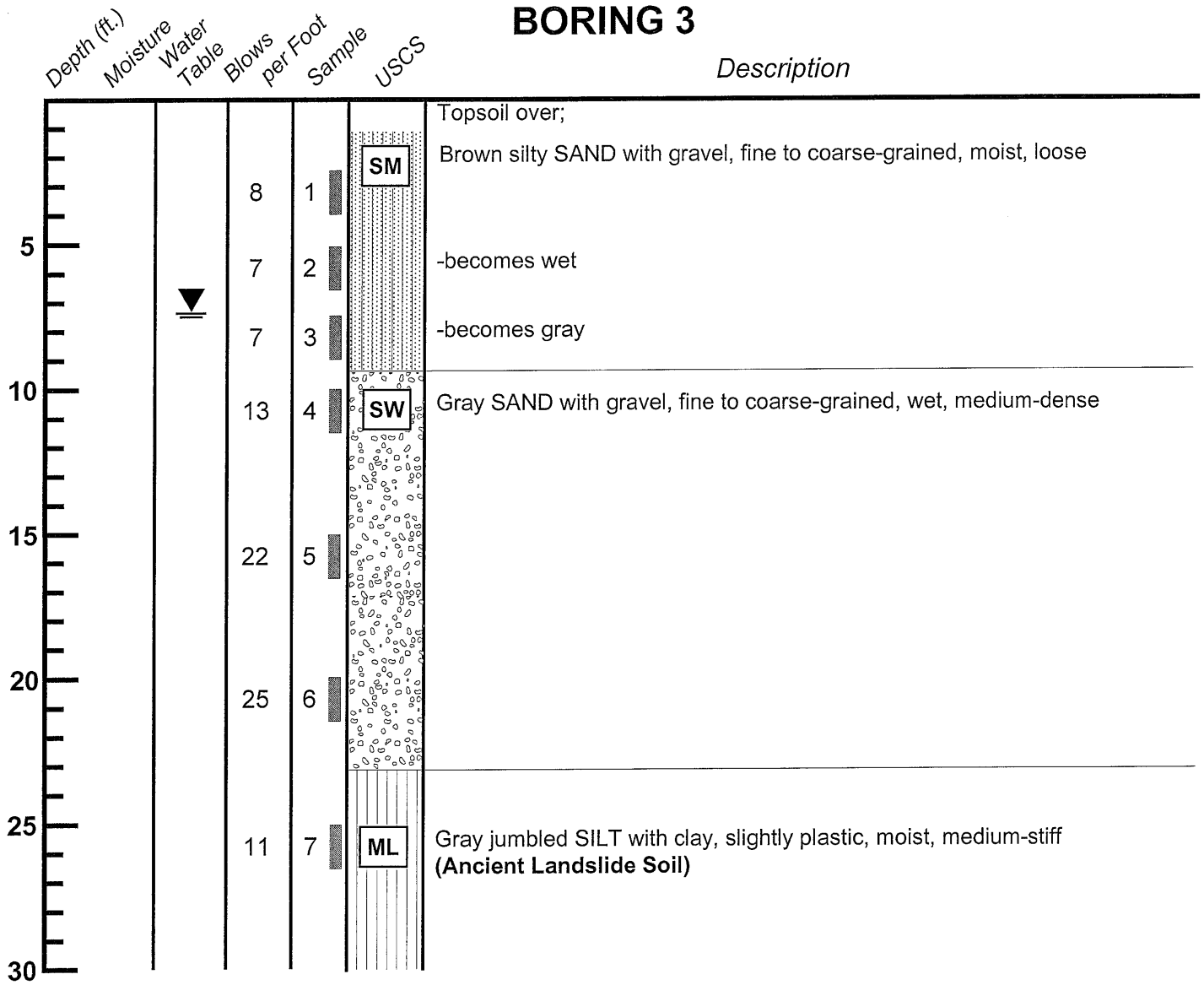

\* Continued on Plate 6.



**TEST BORING LOG**  
7615 East Mercer Way  
Mercer Island, Washington

<b>Job</b> 16095	<b>Date:</b> March 2016	<b>Logged by:</b> TRC	<b>Plate:</b> 5
---------------------	----------------------------	--------------------------	--------------------

Depth (ft.)  
 Moisture  
 Water  
 Table  
 Blows  
 per Foot  
 Sample  
 USCS

# BORING 3 (CONTINUED)

Description

35 40 45 50 55 60	12	8	ML	Gray jumbled SILT with clay, slightly plastic, moist, stiff (Ancient Landslide Soil)
	14	9		
	9	10	ML	Gray intact SILT, non-plastic, moist, loose
	14	11	SP	Gray SAND with silt, very fine-grained, wet, medium-dense
	23	12	MH	Gray clayey SILT, plastic, moist, very stiff

- \* Test boring was terminated at 51.5 feet on March 31, 2016.
- \* Groundwater was encountered at 7.5 feet during drilling.



**TEST BORING LOG**  
 7615 East Mercer Way  
 Mercer Island, Washington

<b>Job</b> 16095	<b>Date:</b> March 2016	<b>Logged by:</b> TRC	<b>Plate:</b> 6
---------------------	----------------------------	--------------------------	--------------------

# BORING 4

Depth (ft.)  
Moisture  
Water  
Table  
Blows  
per Foot  
Sample  
USCS

Description

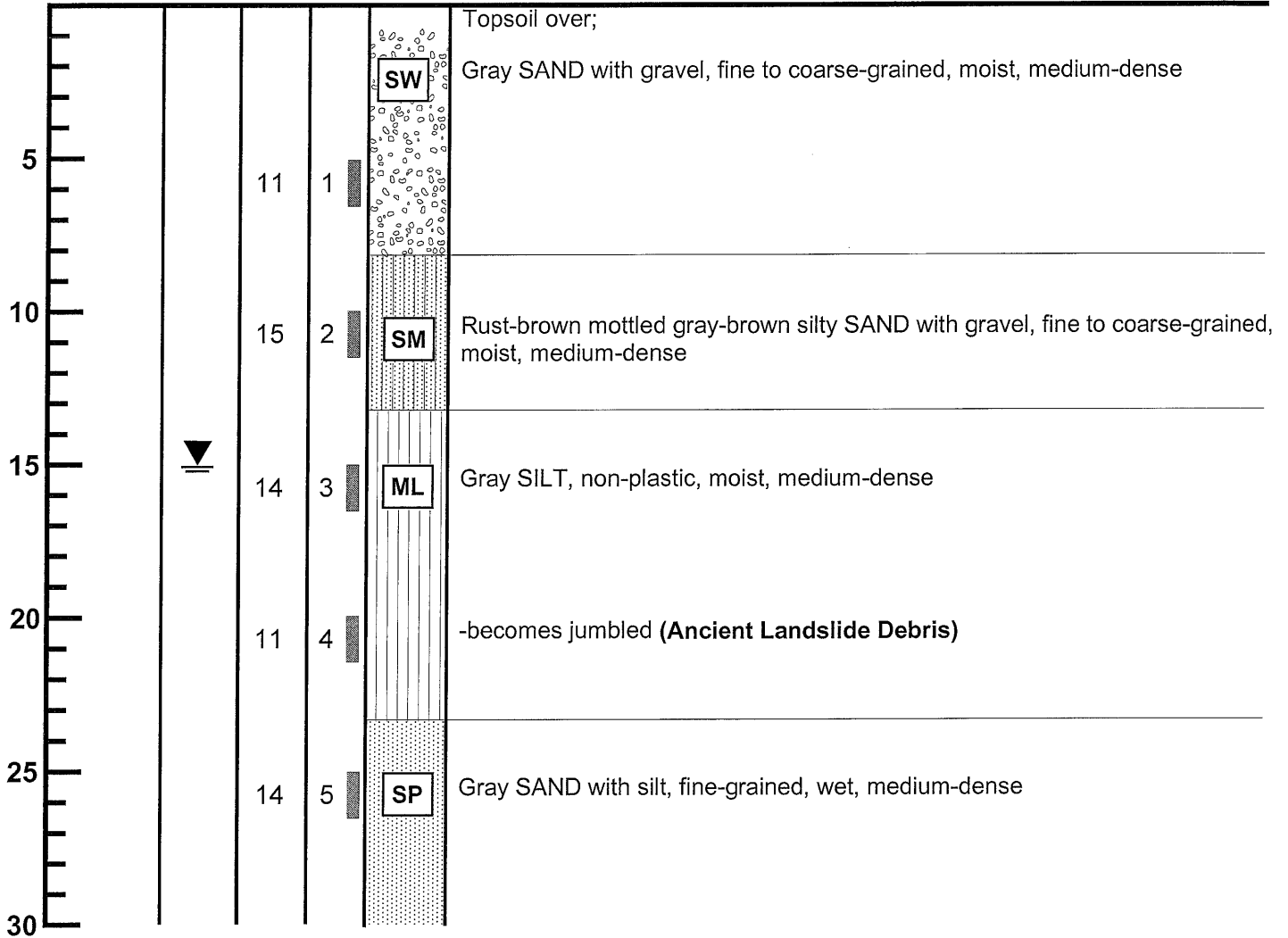

\* Continued on Plate 8.



**GEOTECH**  
CONSULTANTS, INC.

## TEST BORING LOG

7615 East Mercer Way  
Mercer Island, Washington

<b>Job</b> 16095	<b>Date:</b> March 2016	<b>Logged by:</b> TRC	<b>Plate:</b> 7
---------------------	----------------------------	--------------------------	--------------------

Depth (ft.)  
Moisture  
Water  
Table  
Blows  
per Foot  
Sample  
USCS

# BORING 4 (CONTINUED)

Description

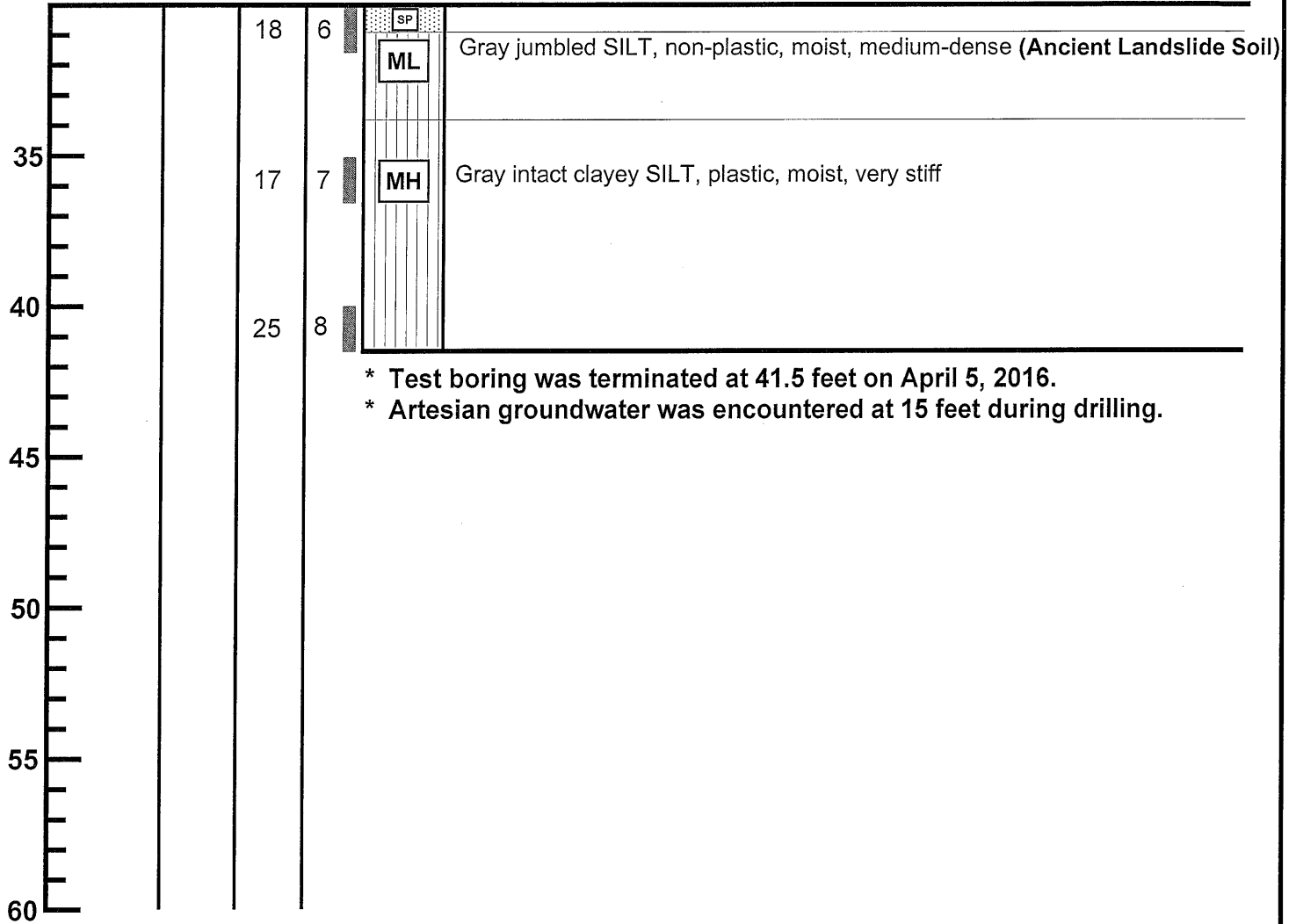

- \* Test boring was terminated at 41.5 feet on April 5, 2016.
- \* Artesian groundwater was encountered at 15 feet during drilling.



**TEST BORING LOG**  
7615 East Mercer Way  
Mercer Island, Washington

<b>Job</b> 16095	<b>Date:</b> March 2016	<b>Logged by:</b> TRC	<b>Plate:</b> 8
---------------------	----------------------------	--------------------------	--------------------

# BORING 5

Depth (ft.)  
Moisture  
Water  
Table  
Blows  
per Foot  
Sample  
USCS

Description

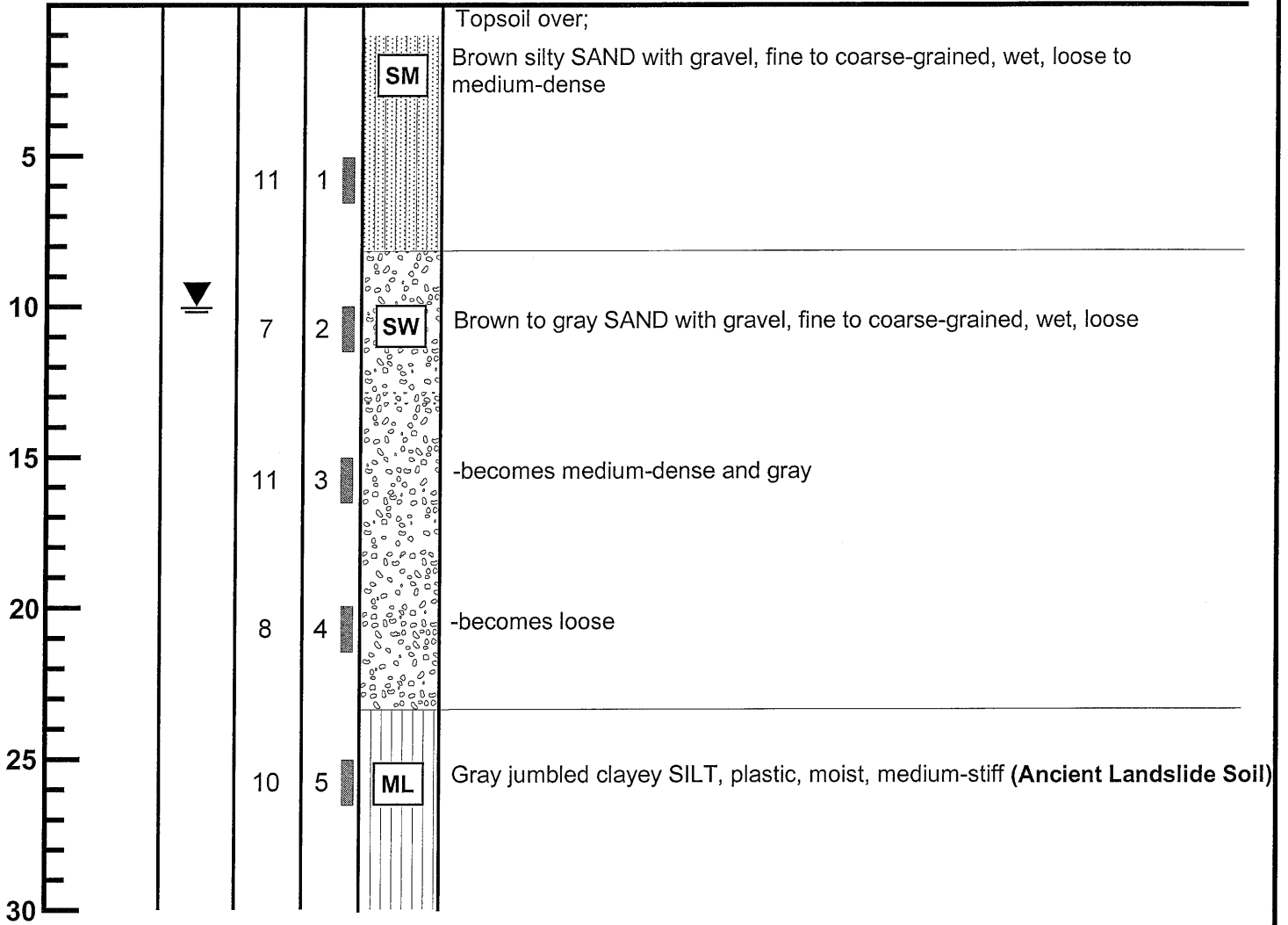

\* Continued on Plate 8.



**TEST BORING LOG**  
7615 East Mercer Way  
Mercer Island, Washington

<b>Job</b> 16095	<b>Date:</b> March 2016	<b>Logged by:</b> TRC	<b>Plate:</b> 9
---------------------	----------------------------	--------------------------	--------------------

Depth (ft.)

Moisture  
Water  
Table

Blows  
per Foot

Sample

# BORING 5 (CONTINUED)

USCS

Description

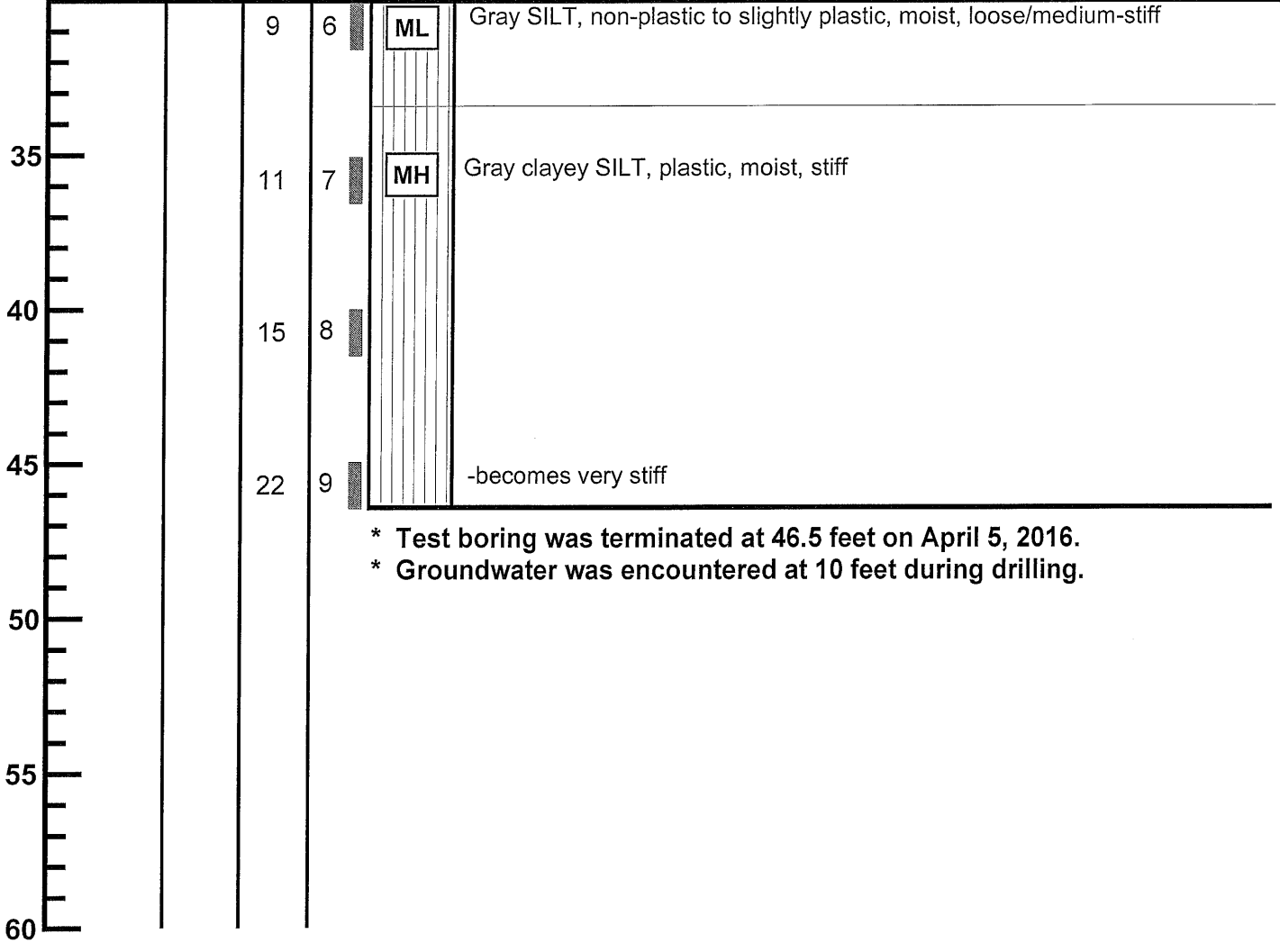

- \* Test boring was terminated at 46.5 feet on April 5, 2016.
- \* Groundwater was encountered at 10 feet during drilling.



**GEOTECH**  
CONSULTANTS, INC.

## TEST BORING LOG

7615 East Mercer Way  
Mercer Island, Washington

<b>Job</b> 16095	<b>Date:</b> March 2016	<b>Logged by:</b> TRC	<b>Plate:</b> 10
---------------------	----------------------------	--------------------------	------------------

# BORING 6

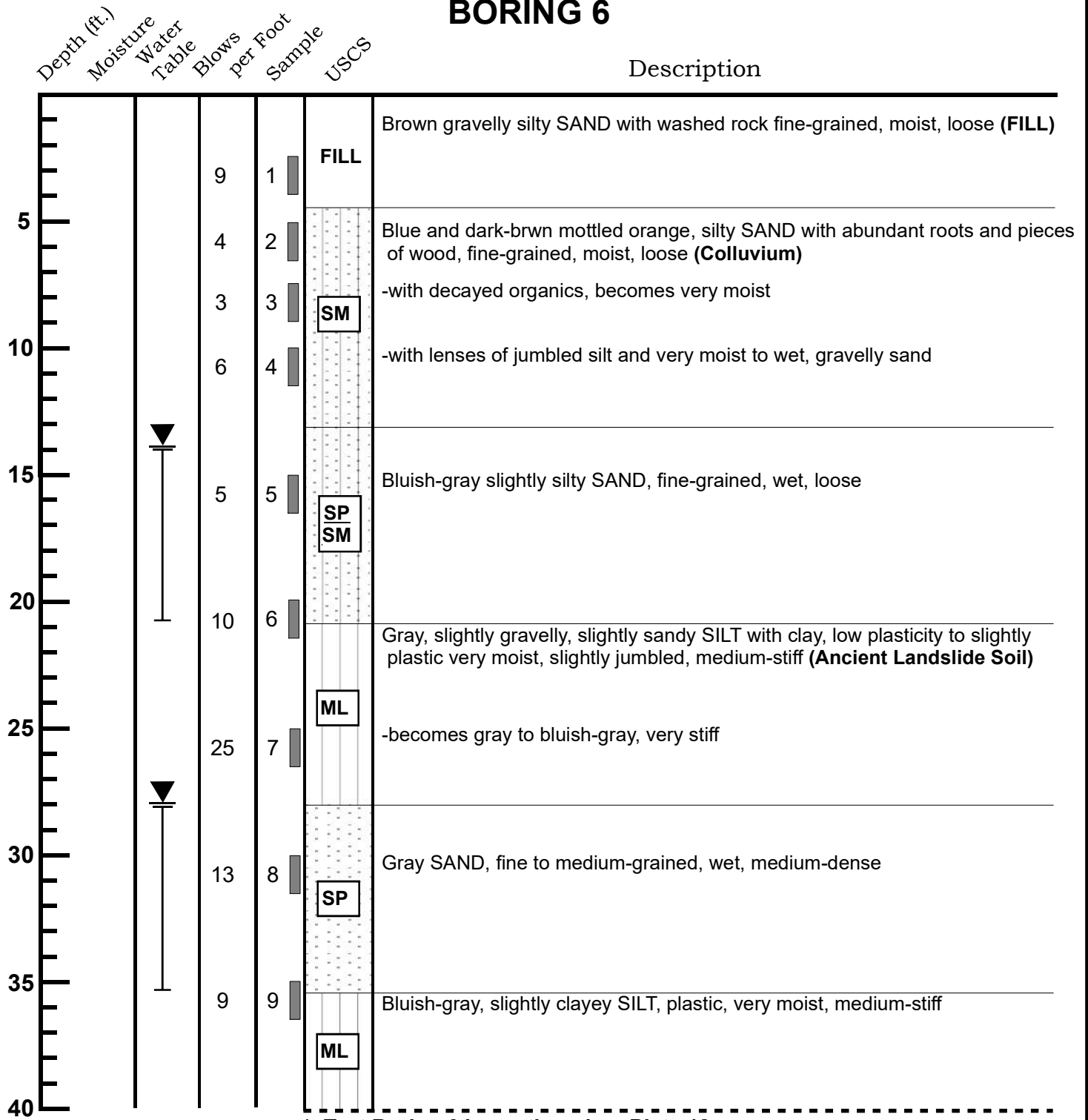

**TEST BORING LOG**  
 7615 East Mercer Way  
 Mercer Island, Washington

<b>Job</b> 23177	<b>Date:</b> June 2023	<b>Logged by:</b> MKM	<b>Plate:</b> 11
---------------------	---------------------------	--------------------------	---------------------

# BORING 6 (Continued)

Depth (ft.)	Moisture Water Table	Blows per Foot	Sample	USCS	Description
40		13	10	ML	Gray clayey, slighty sandy SILT, plastic moist, slightly jumbled, medium-stiff to stiff -driller noted increased output pressure past 42 feet
45		21	11		Gray slightly clayey SILT, plastic moist, intact, very stiff
50		20	12	ML	
55		17	13		
60					

- \* Test boring was terminated at 56.5 feet on June 14, 2023.
- \* Perched groundwater was encountered from 14 to 21 feet and from 28 to 35.5 feet during drilling.



## TEST BORING LOG

7615 East Mercer Way  
Mercer Island, Washington

<b>Job</b> 23177	<b>Date:</b> June 2023	<b>Logged by:</b> MKM	<b>Plate:</b> 12
---------------------	---------------------------	--------------------------	---------------------

# BORING 7

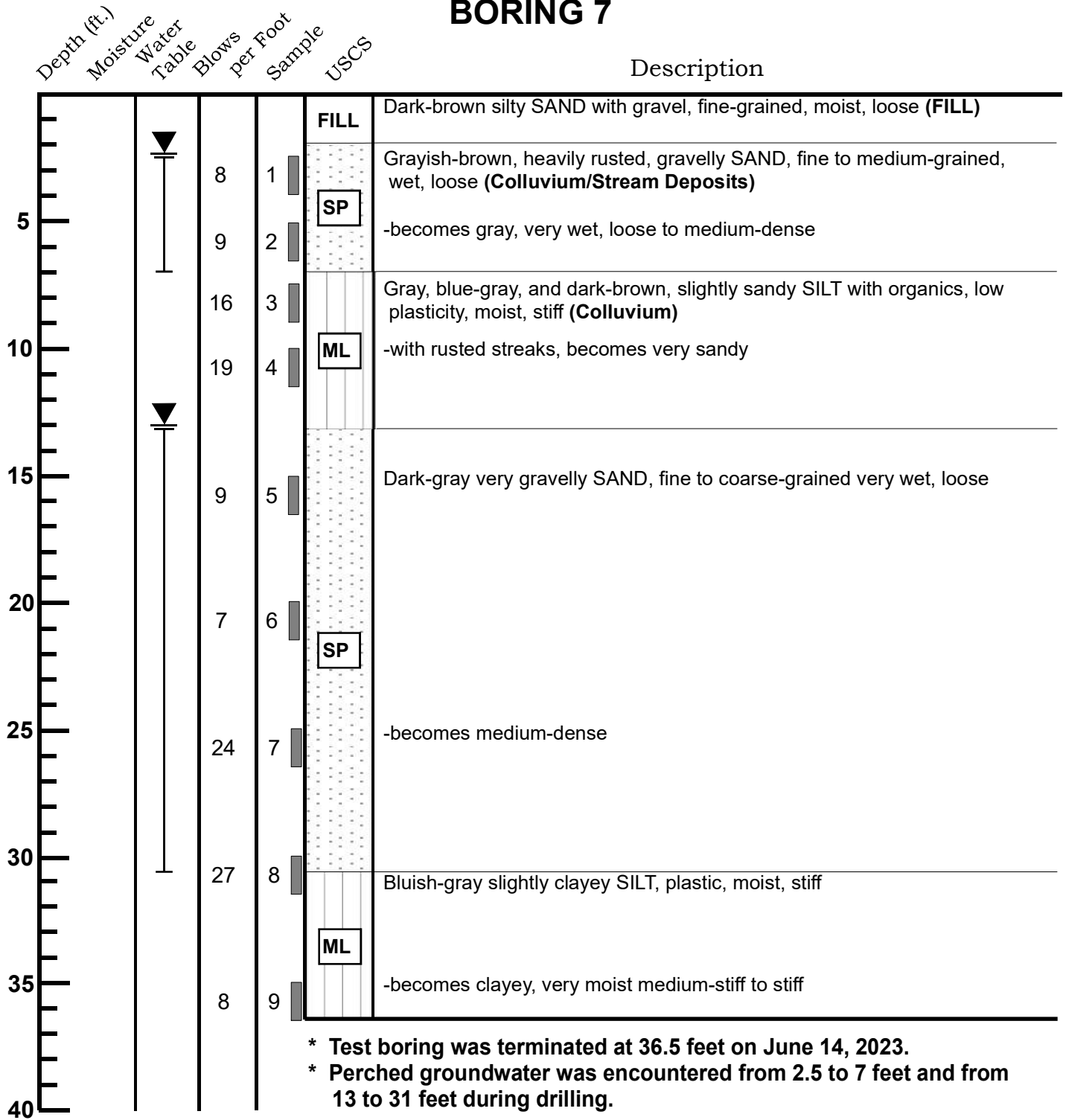

<b>TEST BORING LOG</b>			
7615 East Mercer Way Mercer Island, Washington			
<b>Job</b> 23177	<b>Date:</b> June 2023	<b>Logged by:</b> MKM	<b>Plate:</b> 13

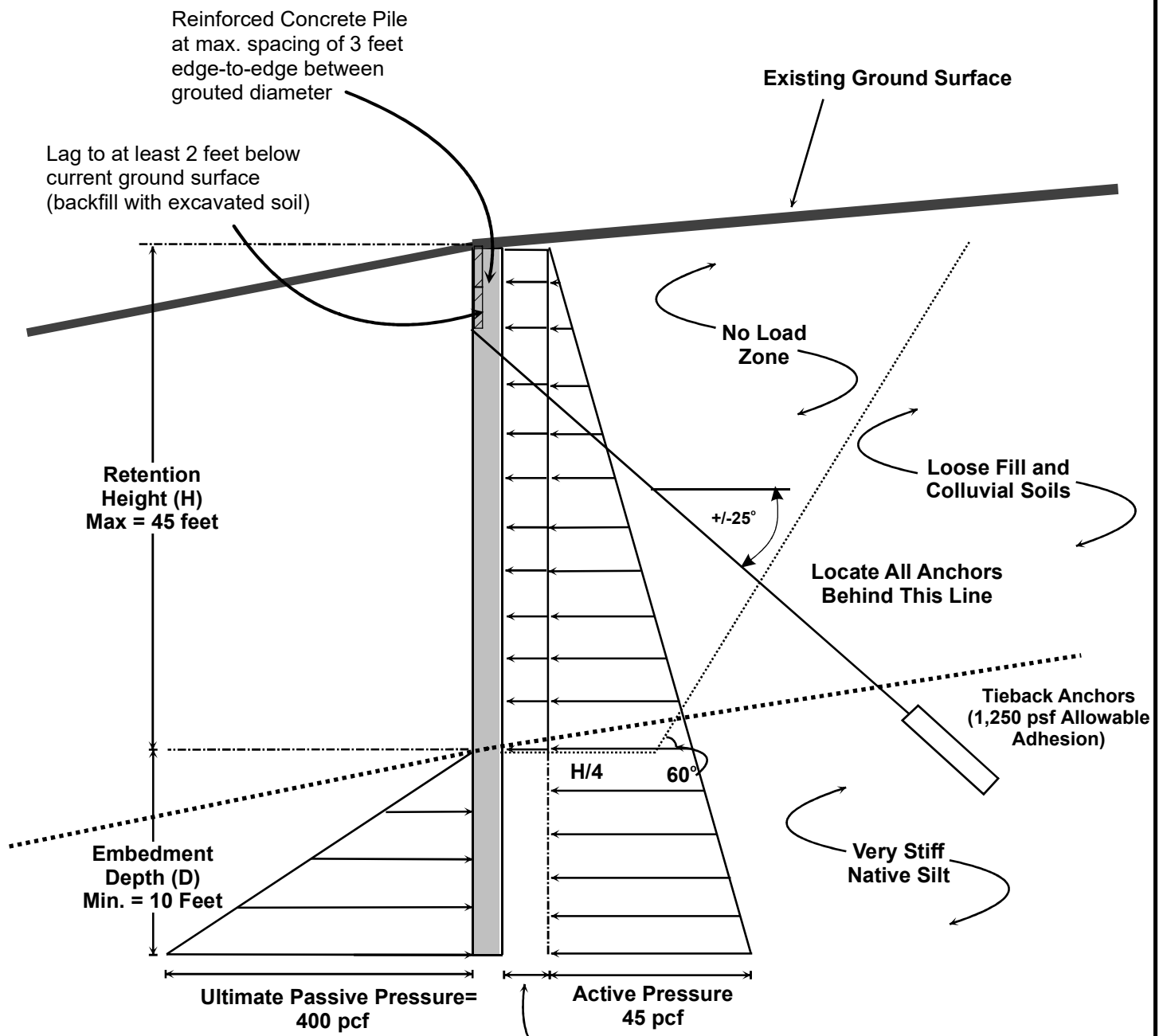

**Notes:**

- (1) The report should be referenced for specifics regarding design and installation.
- (2) Active pressures act over the pile spacing within the retained height (H), and on the pile diameter within the embedment zone (D).
- (3) Passive pressures act over twice the grouted soldier pile diameter or the pile spacing, whichever is smaller.
- (4) It is assumed that no hydrostatic pressures act on the back of the shoring walls.
- (5) Cut slopes or adjacent structures positioned above or behind shoring will exert additional pressures on the shoring wall.



**TYPICAL STABILIZATION WALL**  
7615 East Mercer Way  
Mercer Island, Washington

<b>Job No:</b> 23177	<b>Date:</b> June 2023	<b>Plate:</b> 14
-------------------------	---------------------------	---------------------

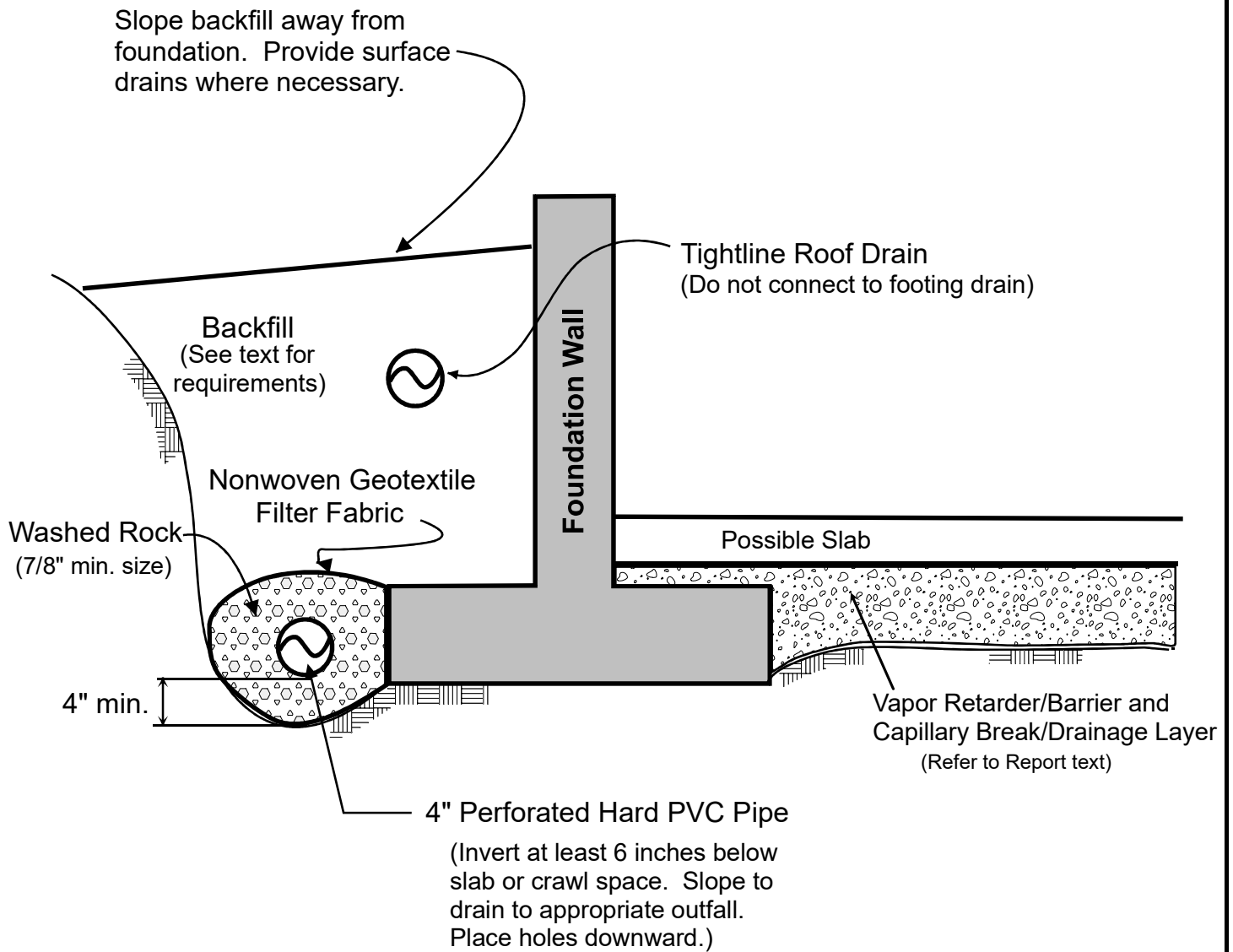

**NOTES:**

- (1) In crawl spaces, provide an outlet drain to prevent buildup of water that bypasses the perimeter footing drains.
- (2) Refer to report text for additional drainage, waterproofing, and slab considerations.



**FOOTING DRAIN DETAIL**  
7615 East Mercer Way  
Mercer Island, Washington

<b>Job No:</b> 23177	<b>Date:</b> June 2023	<b>Plate:</b> 15
-------------------------	---------------------------	---------------------

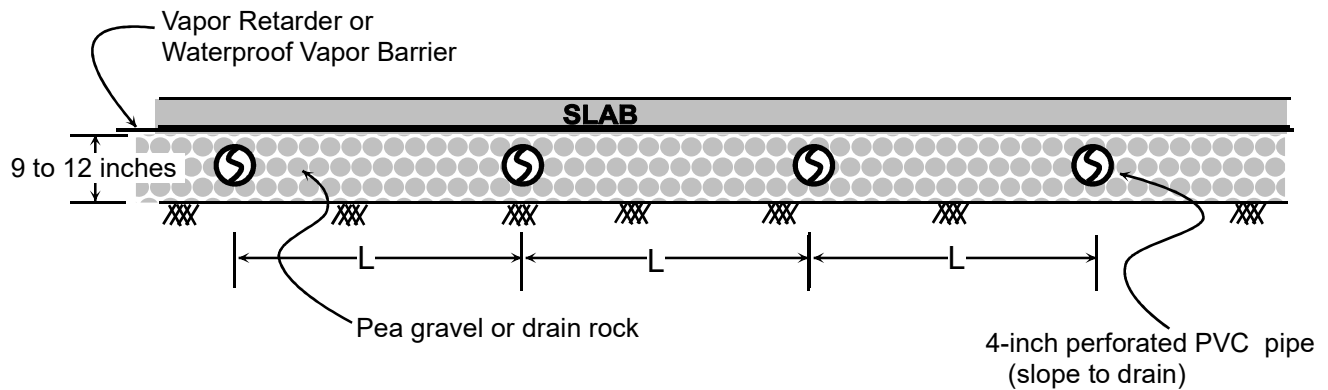

**NOTES:**

- (1) Refer to the report text for additional drainage and waterproofing considerations.
- (2) The typical maximum underslab drain separation (L) is 15 to 20 feet.
- (3) No filter fabric is necessary beneath the pipes as long as a minimum thickness of 4 inches of rock is maintained beneath the pipes.
- (4) The underslab drains and foundation drains should discharge to a suitable outfall.



**TYPICAL UNDERSLAB DRAINAGE**  
 7615 East Mercer Way  
 Mercer Island, Washington

<b>Job No:</b> 23177	<b>Date:</b> June 2023	<b>Plate:</b> 16
-------------------------	---------------------------	---------------------

**Appendix A**  
**Slope Stability Analysis**  
**JN 23177**  
**Cheshire**

23177 - Cheshire  
 Static

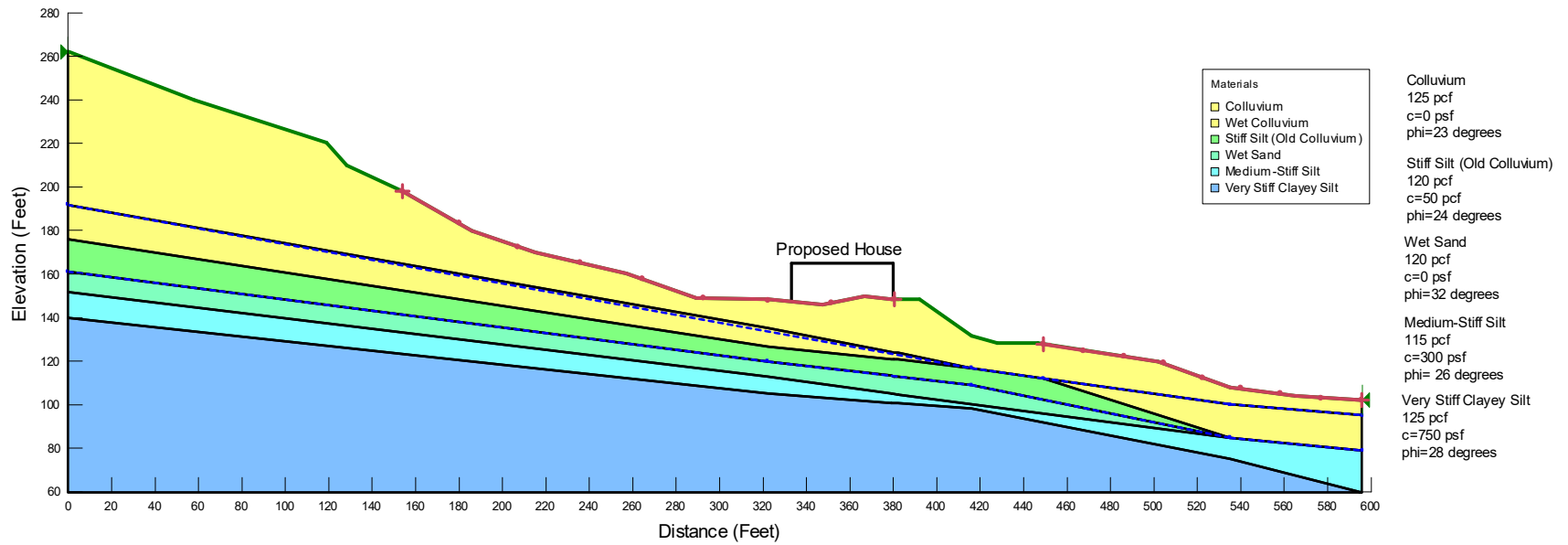

23177 - Cheshire  
 Static

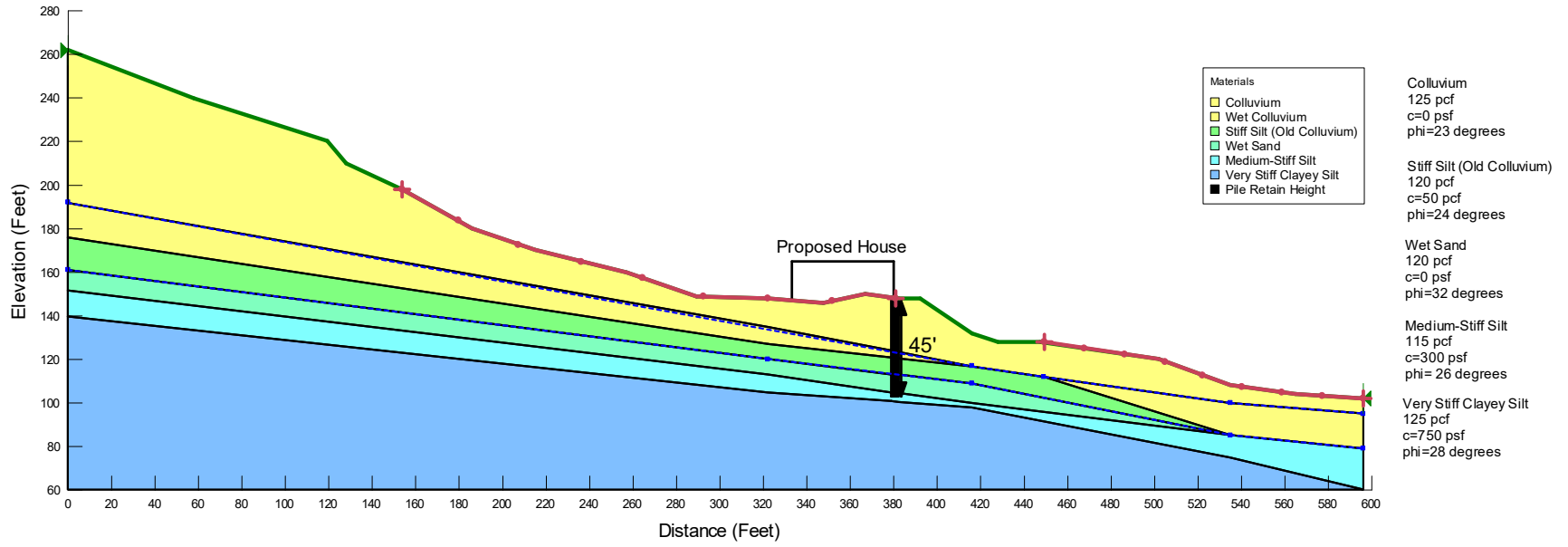

23177 - Cheshire  
 Static

3.0

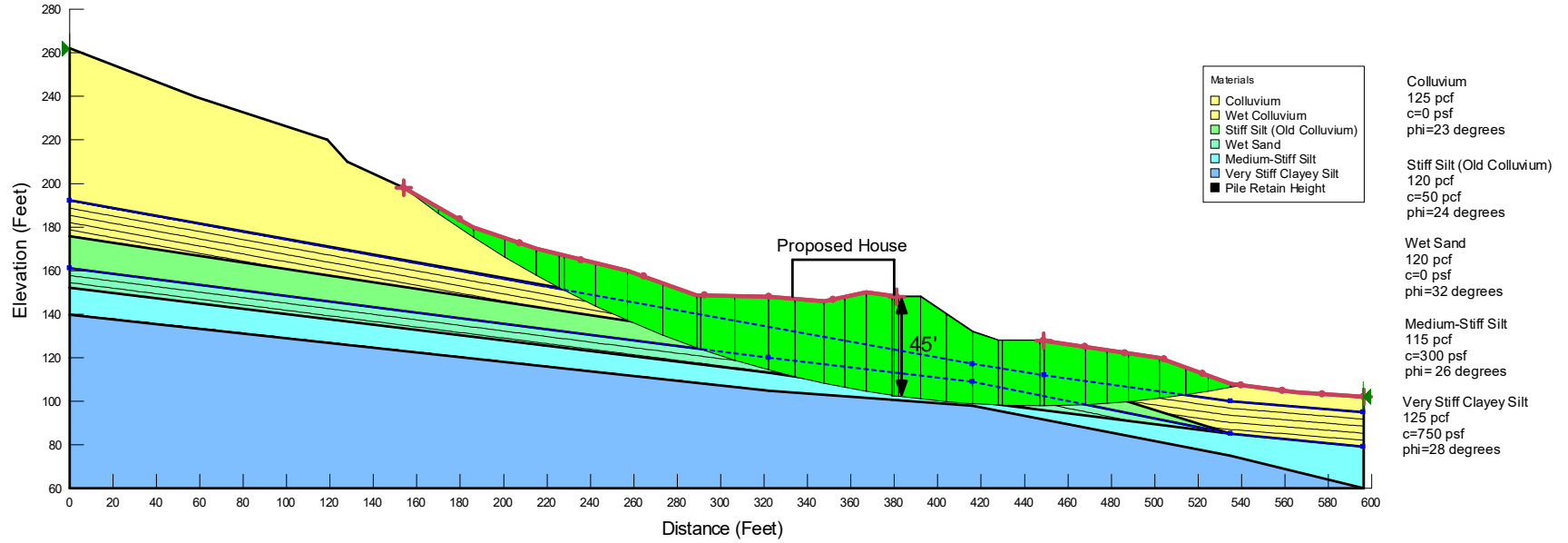

# Static

Report generated using GeoStudio 2012. Copyright © 1991-2016 GEO-SLOPE International Ltd.

## File Information

File Version: 8.15  
Title: 23177 Cheshire  
Created By: Matt McGinnis  
Last Edited By: Matt McGinnis  
Revision Number: 27  
Date: 9/12/2023  
Time: 7:03:01 AM  
Tool Version: 8.15.6.13446  
File Name: 23177 AA' - Failure east of house.gsz  
Directory: C:\Users\MattM\Geotech Consultants\Shared Documents - Documents\2023 Jobs\23177 Cheshire (DRW)\23177 Slope Stability\  
Last Solved Date: 9/12/2023  
Last Solved Time: 7:03:06 AM

## Project Settings

Length(L) Units: Feet  
Time(t) Units: Seconds  
Force(F) Units: Pounds  
Pressure(p) Units: psf  
Strength Units: psf  
Unit Weight of Water: 62.4 pcf  
View: 2D  
Element Thickness: 1

## Analysis Settings

### Static

Kind: SLOPE/W  
Method: Morgenstern-Price  
Settings  
Side Function  
Interslice force function option: Half-Sine  
PWP Conditions Source: Piezometric Line  
Apply Phreatic Correction: Yes  
Use Staged Rapid Drawdown: No  
Slip Surface  
Direction of movement: Left to Right  
Use Passive Mode: No  
Slip Surface Option: Entry and Exit  
Critical slip surfaces saved: 1  
Resisting Side Maximum Convex Angle: 1 °  
Driving Side Maximum Convex Angle: 5 °  
Optimize Critical Slip Surface Location: No  
Tension Crack

Tension Crack Option: (none)

F of S Distribution

F of S Calculation Option: Constant

Advanced

Number of Slices: 30

F of S Tolerance: 0.001

Minimum Slip Surface Depth: 0.1 ft

Search Method: Root Finder

Tolerable difference between starting and converged F of S: 3

Maximum iterations to calculate converged lambda: 20

Max Absolute Lambda: 2

## Materials

### Colluvium

Model: Mohr-Coulomb

Unit Weight: 125 pcf

Cohesion': 0 psf

Phi': 23 °

Phi-B: 0 °

### Wet Colluvium

Model: Mohr-Coulomb

Unit Weight: 125 pcf

Cohesion': 0 psf

Phi': 23 °

Phi-B: 0 °

Pore Water Pressure

Piezometric Line: 1

### Stiff Silt (Old Colluvium)

Model: Mohr-Coulomb

Unit Weight: 120 pcf

Cohesion': 50 psf

Phi': 24 °

Phi-B: 0 °

### Wet Sand

Model: Mohr-Coulomb

Unit Weight: 120 pcf

Cohesion': 0 psf

Phi': 32 °

Phi-B: 0 °

Pore Water Pressure

Piezometric Line: 2

### Medium-Stiff Silt

Model: Mohr-Coulomb

Unit Weight: 120 pcf

Cohesion': 300 psf

Phi': 26 °

Phi-B: 0 °

## Very Stiff Clayey Silt

Model: Mohr-Coulomb

Unit Weight: 125 pcf

Cohesion: 750 psf

Phi: 28 °

Phi-B: 0 °

## Pile Retain Height

Model: High Strength

Unit Weight: 150 pcf

Pore Water Pressure

Piezometric Line: 1

## Slip Surface Entry and Exit

Left Projection: Range

Left-Zone Left Coordinate: (154, 198) ft

Left-Zone Right Coordinate: (380.75662, 148) ft

Left-Zone Increment: 8

Right Projection: Range

Right-Zone Left Coordinate: (449.06184, 127.7001) ft

Right-Zone Right Coordinate: (596, 102) ft

Right-Zone Increment: 8

Radius Increments: 8

## Slip Surface Limits

Left Coordinate: (0, 262) ft

Right Coordinate: (596, 102) ft

## Piezometric Lines

### Piezometric Line 1

#### Coordinates

	X (ft)	Y (ft)
Coordinate 1	0	192
Coordinate 2	416	117
Coordinate 3	449	112
Coordinate 4	535	100
Coordinate 5	596	95

### Piezometric Line 2

#### Coordinates

	X (ft)	Y (ft)
Coordinate 1	0	161
Coordinate 2	322	120
Coordinate 3	416	109

Coordinate 4	535	85
Coordinate 5	596	79

## Seismic Coefficients

Horz Seismic Coef.: 0

## Points

	X (ft)	Y (ft)
Point 1	0	262
Point 2	58	240
Point 3	119	220
Point 4	128	210
Point 5	154	198
Point 6	186	180
Point 7	215	170
Point 8	257	160
Point 9	289	149
Point 10	322	148
Point 11	347.5	146
Point 12	367	150
Point 13	380	148
Point 14	392	148
Point 15	428	128
Point 16	447	128
Point 17	502	120
Point 18	565	104
Point 19	322	135
Point 20	322	127
Point 21	322	120
Point 22	322	113
Point 23	322	105
Point 24	322	92
Point 25	416	132
Point 26	416	117
Point 27	416	109
Point 28	416	98
Point 29	416	91
Point 30	535	100
Point 31	535	108
Point 32	535	85
Point 33	535	75
Point 34	535	61.5
Point 35	596	60
Point 36	0	60
Point 37	0	120
Point 38	0	140
Point 39	416	100

Point 40	596	79
Point 41	0	152
Point 42	0	161
Point 43	449	112
Point 44	0	176
Point 45	596	95
Point 46	0	192
Point 47	596	102
Point 48	382	148
Point 49	382	112
Point 50	382	123.51064
Point 51	382	120.61702
Point 52	382	112.97872
Point 53	380	112
Point 54	380	113.21276
Point 55	380	120.82979
Point 56	380	123.89362
Point 57	382	108
Point 58	380	108
Point 59	379	148.15385
Point 60	379	103
Point 61	379	124.08511
Point 62	379	120.93617
Point 63	379	113.32978
Point 64	379	105.11702
Point 65	382	103
Point 66	382	104.70213
Point 67	379	100.75532
Point 68	382	100.53192

## Regions

	Material	Points	Area (ft <sup>2</sup> )
Region 1	Very Stiff Clayey Silt	67,23,38,37,36,35,33,28,68	27,637
Region 2	Medium-Stiff Silt	60,64,22,41,38,23,67,68,28,33,35,40,32,39,66,65	5,282.8
Region 3	Wet Sand	21,63,64,22,41,42	3,009.6
Region 4	Stiff Silt (Old Colluvium)	20,62,63,21,42,44	3,958.3
Region 5	Wet Colluvium	43,30,45,40,32	1,590.5
Region 6	Wet Colluvium	19,61,62,20,44,46	4,181.7
Region 7	Colluvium	1,2,3,4,5,6,7,8,9,10,11,12,59,61,19,46	12,117
Region 8	Colluvium	14,25,15,16,17,31,18,47,45,30,43,26,50,48	2,856.3
Region 9	Wet Colluvium	26,51,50	49.192
Region 10	Stiff Silt (Old Colluvium)	26,43,32,27,52,51	972.35
Region 11	Pile Retain Height	52,49,53,54	2.1915
Region 12	Pile Retain Height	51,52,54,55	15.255
Region 13	Pile Retain Height	50,51,55,56	5.9575
Region 14	Pile Retain Height	48,50,56,13	48.596
Region 15	Pile Retain Height	49,57,58,53	8
Region 16	Pile Retain Height	13,56,61,59	24.088

Region 17	Pile Retain Height	56,55,62,61	3.1064
Region 18	Pile Retain Height	55,54,63,62	7.6117
Region 19	Pile Retain Height	54,53,58,57,66,64,63	14.543
Region 20	Pile Retain Height	66,65,60,64	5.7287
Region 21	Wet Sand	49,52,27,32,39,66,57	829.2

## Current Slip Surface

Slip Surface: 57

F of S: 3.2

Volume: 10,105.063 ft<sup>3</sup>

Weight: 1,250,259.5 lbs

Resisting Moment: 3.4017227e+008 lbs-ft

Activating Moment: 1.0686179e+008 lbs-ft

Resisting Force: 666,532.64 lbs

Activating Force: 209,386.38 lbs

F of S Rank (Analysis): 2 of 729 slip surfaces

F of S Rank (Query): 2 of 729 slip surfaces

Exit: (558.63595, 104.84854) ft

Entry: (154, 198) ft

Radius: 496.96532 ft

Center: (457.61371, 591.43773) ft

## Slip Slices

	X (ft)	Y (ft)	PWP (psf)	Base Normal Stress (psf)	Frictional Strength (psf)	Cohesive Strength (psf)
Slice 1	162	192.07824	0	159.08078	67.525787	0
Slice 2	178	180.71027	0	418.94397	177.83116	0
Slice 3	193.25	170.70855	0	745.0364	316.24919	0
Slice 4	207.75	161.93533	0	1,154.6205	490.10732	0
Slice 5	220.14549	154.91847	0	1,512.1845	641.88424	0
Slice 6	226.35726	151.55873	-22.260331	1,717.899	729.20487	0
Slice 7	234.70731	147.34219	141.58811	1,968.0826	775.3009	0
Slice 8	249.49555	140.22485	410.59858	2,375.8752	834.21044	0
Slice 9	264.7326	133.5065	0	2,606.7437	1,160.5971	50
Slice 10	280.1978	127.29379	0	2,710.3709	1,206.7349	50
Slice 11	288.4652	124.14447	7.7055738	2,732.4986	1,702.6397	0
Slice 12	297.25	121.13779	123.64474	3,042.9835	1,824.2053	0
Slice 13	313.75	115.8292	320.60917	3,638.5338	2,073.2694	0
Slice 14	323.16917	113.00516	422.15948	3,957.3548	2,209.0352	0
Slice 15	330.12875	111.13967	0	4,136.518	2,017.5146	300
Slice 16	341.70958	108.21386	0	4,421.1139	2,156.3213	300
Slice 17	357.25	104.8141	0	5,084.3533	2,479.8048	300

Slice 18	373	101.76643	0	5,668.397	2,764.662	300
Slice 19	379.5	100.65007	0	6,925.8023	3,682.5144	750
Slice 20	381	100.41446	0	6,953.9022	3,697.4554	750
Slice 21	387	99.540666	0	5,914.3342	3,144.7073	750
Slice 22	398	98.097875	0	5,667.5528	3,013.4913	750
Slice 23	410	96.7953	0	4,898.5996	2,604.6316	750
Slice 24	422	95.786632	0	4,321.3885	2,297.723	750
Slice 25	429.19542	95.287047	0	4,154.9622	2,209.2326	750
Slice 26	438.69542	94.902167	0	4,204.838	2,050.8365	300
Slice 27	448	94.56641	0	4,257.8445	2,076.6895	300
Slice 28	454.40681	94.512168	0	4,167.0113	2,032.3872	300
Slice 29	465.97021	94.580822	260.30025	3,981.3972	2,325.1995	0
Slice 30	478.28339	94.940673	89.819953	3,736.6529	2,278.7941	0
Slice 31	491.85026	95.708754	0	3,371.916	1,501.2737	50
Slice 32	500.63027	96.339539	517.59171	3,113.467	1,101.8837	0
Slice 33	509.7974	97.281967	381.61369	2,594.8917	939.48079	0
Slice 34	525.3922	99.179	132.30924	1,606.2051	625.63169	0
Slice 35	534.0948	100.3936	0	1,034.6257	439.17256	0
Slice 36	540.90899	101.53927	0	737.70081	313.13542	0
Slice 37	552.72696	103.69624	0	250.89783	106.49981	0

23177 - Cheshire  
 Seismic, kh=0.34g

1.1

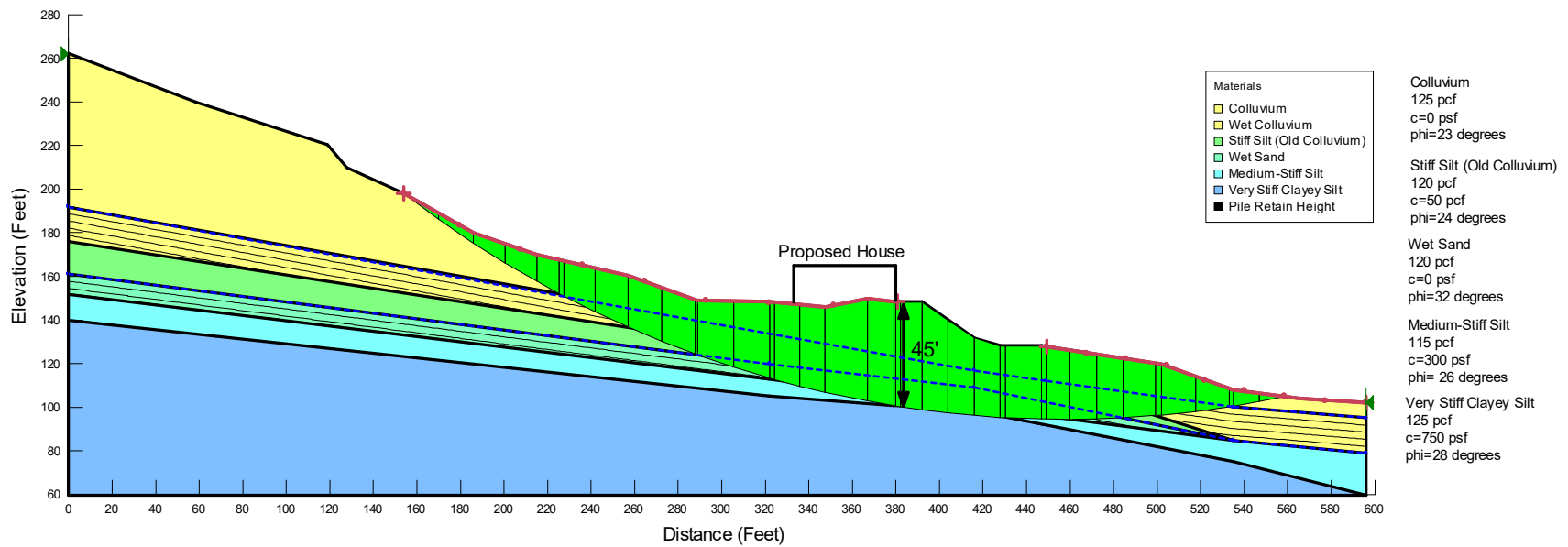

# Seismic

Report generated using GeoStudio 2012. Copyright © 1991-2016 GEO-SLOPE International Ltd.

## File Information

File Version: 8.15  
Title: 23177 Cheshire  
Created By: Matt McGinnis  
Last Edited By: Matt McGinnis  
Revision Number: 27  
Date: 9/12/2023  
Time: 7:03:01 AM  
Tool Version: 8.15.6.13446  
File Name: 23177 AA' - Failure east of house.gsz  
Directory: C:\Users\MattM\Geotech Consultants\Shared Documents - Documents\2023 Jobs\23177 Cheshire (DRW)\23177 Slope Stability\  
Last Solved Date: 9/12/2023  
Last Solved Time: 7:03:04 AM

## Project Settings

Length(L) Units: Feet  
Time(t) Units: Seconds  
Force(F) Units: Pounds  
Pressure(p) Units: psf  
Strength Units: psf  
Unit Weight of Water: 62.4 pcf  
View: 2D  
Element Thickness: 1

## Analysis Settings

### Seismic

Kind: SLOPE/W  
Method: Morgenstern-Price  
Settings  
Side Function  
Interslice force function option: Half-Sine  
PWP Conditions Source: Piezometric Line  
Apply Phreatic Correction: Yes  
Use Staged Rapid Drawdown: No  
Slip Surface  
Direction of movement: Left to Right  
Use Passive Mode: No  
Slip Surface Option: Entry and Exit  
Critical slip surfaces saved: 1  
Resisting Side Maximum Convex Angle: 1 °  
Driving Side Maximum Convex Angle: 5 °  
Optimize Critical Slip Surface Location: No  
Tension Crack

Tension Crack Option: (none)

F of S Distribution

F of S Calculation Option: Constant

Advanced

Number of Slices: 30

F of S Tolerance: 0.001

Minimum Slip Surface Depth: 0.1 ft

Search Method: Root Finder

Tolerable difference between starting and converged F of S: 3

Maximum iterations to calculate converged lambda: 20

Max Absolute Lambda: 2

## Materials

### Colluvium

Model: Mohr-Coulomb

Unit Weight: 125 pcf

Cohesion': 0 psf

Phi': 23 °

Phi-B: 0 °

### Wet Colluvium

Model: Mohr-Coulomb

Unit Weight: 125 pcf

Cohesion': 0 psf

Phi': 23 °

Phi-B: 0 °

Pore Water Pressure

Piezometric Line: 1

### Stiff Silt (Old Colluvium)

Model: Mohr-Coulomb

Unit Weight: 120 pcf

Cohesion': 50 psf

Phi': 24 °

Phi-B: 0 °

### Wet Sand

Model: Mohr-Coulomb

Unit Weight: 120 pcf

Cohesion': 0 psf

Phi': 32 °

Phi-B: 0 °

Pore Water Pressure

Piezometric Line: 2

### Medium-Stiff Silt

Model: Mohr-Coulomb

Unit Weight: 120 pcf

Cohesion': 300 psf

Phi': 26 °

Phi-B: 0 °

## Very Stiff Clayey Silt

Model: Mohr-Coulomb

Unit Weight: 125 pcf

Cohesion: 750 psf

Phi: 28 °

Phi-B: 0 °

## Pile Retain Height

Model: High Strength

Unit Weight: 150 pcf

Pore Water Pressure

Piezometric Line: 1

## Slip Surface Entry and Exit

Left Projection: Range

Left-Zone Left Coordinate: (154, 198) ft

Left-Zone Right Coordinate: (380.75662, 148) ft

Left-Zone Increment: 8

Right Projection: Range

Right-Zone Left Coordinate: (449.06184, 127.7001) ft

Right-Zone Right Coordinate: (596, 102) ft

Right-Zone Increment: 8

Radius Increments: 8

## Slip Surface Limits

Left Coordinate: (0, 262) ft

Right Coordinate: (596, 102) ft

## Piezometric Lines

### Piezometric Line 1

#### Coordinates

	X (ft)	Y (ft)
Coordinate 1	0	192
Coordinate 2	416	117
Coordinate 3	449	112
Coordinate 4	535	100
Coordinate 5	596	95

### Piezometric Line 2

#### Coordinates

	X (ft)	Y (ft)
Coordinate 1	0	161
Coordinate 2	322	120
Coordinate 3	416	109

Coordinate 4	535	85
Coordinate 5	596	79

## Seismic Coefficients

Horz Seismic Coef.: 0.34

## Points

	X (ft)	Y (ft)
Point 1	0	262
Point 2	58	240
Point 3	119	220
Point 4	128	210
Point 5	154	198
Point 6	186	180
Point 7	215	170
Point 8	257	160
Point 9	289	149
Point 10	322	148
Point 11	347.5	146
Point 12	367	150
Point 13	380	148
Point 14	392	148
Point 15	428	128
Point 16	447	128
Point 17	502	120
Point 18	565	104
Point 19	322	135
Point 20	322	127
Point 21	322	120
Point 22	322	113
Point 23	322	105
Point 24	322	92
Point 25	416	132
Point 26	416	117
Point 27	416	109
Point 28	416	98
Point 29	416	91
Point 30	535	100
Point 31	535	108
Point 32	535	85
Point 33	535	75
Point 34	535	61.5
Point 35	596	60
Point 36	0	60
Point 37	0	120
Point 38	0	140
Point 39	416	100

Point 40	596	79
Point 41	0	152
Point 42	0	161
Point 43	449	112
Point 44	0	176
Point 45	596	95
Point 46	0	192
Point 47	596	102
Point 48	382	148
Point 49	382	112
Point 50	382	123.51064
Point 51	382	120.61702
Point 52	382	112.97872
Point 53	380	112
Point 54	380	113.21276
Point 55	380	120.82979
Point 56	380	123.89362
Point 57	382	108
Point 58	380	108
Point 59	379	148.15385
Point 60	379	103
Point 61	379	124.08511
Point 62	379	120.93617
Point 63	379	113.32978
Point 64	379	105.11702
Point 65	382	103
Point 66	382	104.70213
Point 67	379	100.75532
Point 68	382	100.53192

## Regions

	Material	Points	Area (ft <sup>2</sup> )
Region 1	Very Stiff Clayey Silt	67,23,38,37,36,35,33,28,68	27,637
Region 2	Medium-Stiff Silt	60,64,22,41,38,23,67,68,28,33,35,40,32,39,66,65	5,282.8
Region 3	Wet Sand	21,63,64,22,41,42	3,009.6
Region 4	Stiff Silt (Old Colluvium)	20,62,63,21,42,44	3,958.3
Region 5	Wet Colluvium	43,30,45,40,32	1,590.5
Region 6	Wet Colluvium	19,61,62,20,44,46	4,181.7
Region 7	Colluvium	1,2,3,4,5,6,7,8,9,10,11,12,59,61,19,46	12,117
Region 8	Colluvium	14,25,15,16,17,31,18,47,45,30,43,26,50,48	2,856.3
Region 9	Wet Colluvium	26,51,50	49.192
Region 10	Stiff Silt (Old Colluvium)	26,43,32,27,52,51	972.35
Region 11	Pile Retain Height	52,49,53,54	2.1915
Region 12	Pile Retain Height	51,52,54,55	15.255
Region 13	Pile Retain Height	50,51,55,56	5.9575
Region 14	Pile Retain Height	48,50,56,13	48.596
Region 15	Pile Retain Height	49,57,58,53	8
Region 16	Pile Retain Height	13,56,61,59	24.088

Region 17	Pile Retain Height	56,55,62,61	3.1064
Region 18	Pile Retain Height	55,54,63,62	7.6117
Region 19	Pile Retain Height	54,53,58,57,66,64,63	14.543
Region 20	Pile Retain Height	66,65,60,64	5.7287
Region 21	Wet Sand	49,52,27,32,39,66,57	829.2

## Current Slip Surface

Slip Surface: 57

F of S: 1.1

Volume: 10,105.063 ft<sup>3</sup>

Weight: 1,250,259.5 lbs

Resisting Moment: 3.2657272e+008 lbs-ft

Activating Moment: 3.0471979e+008 lbs-ft

Resisting Force: 642,368.19 lbs

Activating Force: 599,350.11 lbs

F of S Rank (Analysis): 2 of 729 slip surfaces

F of S Rank (Query): 2 of 729 slip surfaces

Exit: (558.63595, 104.84854) ft

Entry: (154, 198) ft

Radius: 496.96532 ft

Center: (457.61371, 591.43773) ft

## Slip Slices

	X (ft)	Y (ft)	PWP (psf)	Base Normal Stress (psf)	Frictional Strength (psf)	Cohesive Strength (psf)
Slice 1	162	192.07824	0	131.67596	55.893129	0
Slice 2	178	180.71027	0	338.98502	143.8906	0
Slice 3	193.25	170.70855	0	591.66731	251.14787	0
Slice 4	207.75	161.93533	0	903.98206	383.71762	0
Slice 5	220.14549	154.91847	0	1,171.3933	497.22697	0
Slice 6	226.35726	151.55873	-22.260331	1,325.6366	562.69936	0
Slice 7	234.70731	147.34219	141.58811	1,512.3098	581.83683	0
Slice 8	249.49555	140.22485	410.59858	1,806.3676	592.46879	0
Slice 9	264.7326	133.5065	0	1,980.7299	881.87776	50
Slice 10	280.1978	127.29379	0	2,069.452	921.3794	50
Slice 11	288.4652	124.14447	7.7055738	2,147.7584	1,337.2534	0
Slice 12	297.25	121.13779	123.64474	2,427.0906	1,439.3527	0
Slice 13	313.75	115.8292	320.60917	2,984.7772	1,664.757	0
Slice 14	323.16917	113.00516	422.15948	3,301.3617	1,799.1252	0
Slice 15	330.12875	111.13967	0	3,530.6885	1,722.0318	300
Slice 16	341.70958	108.21386	0	3,870.3266	1,887.6844	300
Slice 17	357.25	104.8141	0	4,605.0976	2,246.0562	300

Slice 18	373	101.76643	0	5,314.8518	2,592.2264	300
Slice 19	379.5	100.65007	0	6,840.5193	3,637.1686	750
Slice 20	381	100.41446	0	6,890.3556	3,663.6671	750
Slice 21	387	99.540666	0	6,002.3596	3,191.5112	750
Slice 22	398	98.097875	0	5,909.8399	3,142.3176	750
Slice 23	410	96.7953	0	5,293.1138	2,814.3985	750
Slice 24	422	95.786632	0	4,816.7787	2,561.1267	750
Slice 25	429.19542	95.287047	0	4,691.4581	2,494.4925	750
Slice 26	438.69542	94.902167	0	4,517.1838	2,203.1777	300
Slice 27	448	94.56641	0	4,619.143	2,252.9066	300
Slice 28	454.40681	94.512168	0	4,550.3811	2,219.3691	300
Slice 29	465.97021	94.580822	260.30025	4,443.0352	2,613.6629	0
Slice 30	478.28339	94.940673	89.819953	4,206.6051	2,572.4529	0
Slice 31	491.85026	95.708754	0	3,590.0547	1,598.3954	50
Slice 32	500.63027	96.339539	517.59171	3,220.3872	1,147.2686	0
Slice 33	509.7974	97.281967	381.61369	2,708.4854	987.69842	0
Slice 34	525.3922	99.179	132.30924	1,700.8063	665.78749	0
Slice 35	534.0948	100.3936	0	1,105.1346	469.10181	0
Slice 36	540.90899	101.53927	0	787.36231	334.21547	0
Slice 37	552.72696	103.69624	0	267.07816	113.36795	0



## **APPENDIX E**

### Operations and Maintenance Guidelines

**Table V-A.5: Maintenance Standards - Catch Basins**

Maintenance Component	Defect	Conditions When Maintenance is Needed	Results Expected When Maintenance is performed
General	Trash & Debris	Trash or debris which is located immediately in front of the catch basin opening or is blocking inletting capacity of the basin by more than 10%. Trash or debris (in the basin) that exceeds 60 percent of the sump depth as measured from the bottom of basin to invert of the lowest pipe into or out of the basin, but in no case less than a minimum of six inches clearance from the debris surface to the invert of the lowest pipe. Trash or debris in any inlet or outlet pipe blocking more than 1/3 of its height. Dead animals or vegetation that could generate odors that could cause complaints or dangerous gases (e.g., methane).	No Trash or debris located immediately in front of catch basin or on grate opening. No trash or debris in the catch basin. Inlet and outlet pipes free of trash or debris. No dead animals or vegetation present within the catch basin.
	Sediment	Sediment (in the basin) that exceeds 60 percent of the sump depth as measured from the bottom of basin to invert of the lowest pipe into or out of the basin, but in no case less than a minimum of 6 inches clearance from the sediment surface to the invert of the lowest pipe.	No sediment in the catch basin
	Structure Damage to Frame and/or Top Slab	Top slab has holes larger than 2 square inches or cracks wider than 1/4 inch. (Intent is to make sure no material is running into basin). Frame not sitting flush on top slab, i.e., separation of more than 3/4 inch of the frame from the top slab. Frame not securely attached	Top slab is free of holes and cracks. Frame is sitting flush on the riser rings or top slab and firmly attached.
	Fractures or Cracks in Basin Walls/ Bottom	Maintenance person judges that structure is unsound. Grout fillet has separated or cracked wider than 1/2 inch and longer than 1 foot at the joint of any inlet/outlet pipe or any evidence of soil particles entering catch basin through cracks.	Basin replaced or repaired to design standards. Pipe is regouted and secure at basin wall.
	Settlement/ Mis-alignment	If failure of basin has created a safety, function, or design problem.	Basin replaced or repaired to design standards.
	Vegetation	Vegetation growing across and blocking more than 10% of the basin opening. Vegetation growing in inlet/outlet pipe joints that is more than six inches tall and less than six inches apart.	No vegetation blocking opening to basin. No vegetation or root growth present.
	Contamination and Pollution	See <a href="#">Table V-A.1: Maintenance Standards - Detention Ponds</a>	No pollution present.
Catch Basin Cover	Cover Not in Place	Cover is missing or only partially in place. Any open catch basin requires maintenance.	Cover/grate is in place, meets design standards, and is secured
	Locking Mechanism Not Working	Mechanism cannot be opened by one maintenance person with proper tools. Bolts into frame have less than 1/2 inch of thread.	Mechanism opens with proper tools.
	Cover Difficult to Remove	One maintenance person cannot remove lid after applying normal lifting pressure. (Intent is keep cover from sealing off access to maintenance.)	Cover can be removed by one maintenance person.
Ladder	Ladder Rungs Unsafe	Ladder is unsafe due to missing rungs, not securely attached to basin wall, misalignment, rust, cracks, or sharp edges.	Ladder meets design standards and allows maintenance person safe access.
Metal Grates (If Applicable)	Grate opening Unsafe	Grate with opening wider than 7/8 inch.	Grate opening meets design standards.
	Trash and Debris	Trash and debris that is blocking more than 20% of grate surface inletting capacity.	Grate free of trash and debris.
	Damaged or Missing.	Grate missing or broken member(s) of the grate.	Grate is in place, meets the design standards, and is installed and aligned with the flow path.

**Table V-A.21: Maintenance Standards - Bioretention Facilities**

Maintenance Component	Recommended Frequency <sup>a</sup>		Condition when Maintenance is Needed (Standards)	Action Needed (Procedures)
	Inspection	Routine Maintenance		
<b>Facility Footprint</b>				
Earthen side slopes and berms	B, S		Erosion (gullies/ rills) greater than 2 inches deep around inlets, outlet, and alongside slopes	<ul style="list-style-type: none"> <li>Eliminate cause of erosion and stabilize damaged area (regrade, rock, vegetation, erosion control matting)</li> <li>For deep channels or cuts (over 3 inches in ponding depth), temporary erosion control measures should be put in place until permanent repairs can be made.</li> <li>Properly designed, constructed and established facilities with appropriate flow velocities should not have erosion problems except perhaps in extreme events. If erosion problems persist, the following should be reassessed: (1) flow volumes from contributing areas and bioretention facility sizing; (2) flow velocities and gradients within the facility; and (3) flow dissipation and erosion protection strategies at the facility inlet.</li> </ul>
	A		Erosion of sides causes slope to become a hazard	Take actions to eliminate the hazard and stabilize slopes
	A, S		Settlement greater than 3 inches (relative to undisturbed sections of berm)	Restore to design height
	A, S		Downstream face of berm wet, seeps or leaks evident	Plug any holes and compact berm (may require consultation with engineer, particularly for larger berms)
	A		Any evidence of rodent holes or water piping in berm	<ul style="list-style-type: none"> <li>Eradicate rodents (see "Pest control")</li> <li>Fill holes and compact (may require consultation with engineer, particularly for larger berms)</li> </ul>
Concrete sidewalls	A		Cracks or failure of concrete sidewalls	<ul style="list-style-type: none"> <li>Repair/ seal cracks</li> <li>Replace if repair is insufficient</li> </ul>
Rockery sidewalls	A		Rockery side walls are insecure	Stabilize rockery sidewalls (may require consultation with engineer, particularly for walls 4 feet or greater in height)
Facility area		All maintenance visits (at least biannually)	Trash and debris present	Clean out trash and debris
Facility bottom area	A, S		Accumulated sediment to extent that infiltration rate is reduced (see "Ponded water") or surface storage capacity significantly impacted	<ul style="list-style-type: none"> <li>Remove excess sediment</li> <li>Replace any vegetation damaged or destroyed by sediment accumulation and removal</li> <li>Mulch newly planted vegetation</li> <li>Identify and control the sediment source (if feasible)</li> <li>If accumulated sediment is recurrent, consider adding presettlement or installing berms to create a forebay at the inlet</li> </ul>
		During/after fall leaf drop	Accumulated leaves in facility	Remove leaves if there is a risk to clogging outlet structure or water flow is impeded
Low permeability check dams and weirs	A, S		Sediment, vegetation, or debris accumulated at or blocking (or having the potential to block) check dam, flow control weir or orifice	Clear the blockage
	A, S		Erosion and/or undercutting present	Repair and take preventative measures to prevent future erosion and/or undercutting
	A		Grade board or top of weir damaged or not level	Restore to level position

**Table V-A.21: Maintenance Standards - Bioretention Facilities (continued)**

Maintenance Component	Recommended Frequency <sup>a</sup>		Condition when Maintenance is Needed (Standards)	Action Needed (Procedures)
	Inspection	Routine Maintenance		
Ponded water	B, S		Excessive ponding water: Water overflows during storms smaller than the design event or ponded water remains in the basin 48 hours or longer after the end of a storm.	<p>Determine cause and resolve in the following order:</p> <ol style="list-style-type: none"> <li>1. Confirm leaf or debris buildup in the bottom of the facility is not impeding infiltration. If necessary, remove leaf litter/debris.</li> <li>2. Ensure that underdrain (if present) is not clogged. If necessary, clear underdrain.</li> <li>3. Check for other water inputs (e.g., groundwater, illicit connections).</li> <li>4. Verify that the facility is sized appropriately for the contributing area. Confirm that the contributing area has not increased. If steps #1-4 do not solve the problem, the bioretention soil is likely clogged by sediment accumulation at the surface or has become overly compacted. Dig a small hole to observe soil profile and identify compaction depth or clogging front to help determine the soil depth to be removed or otherwise rehabilitated (e.g., tilled). Consultation with an engineer is recommended.</li> </ol>
Bioretention soil mix	As needed		Bioretention soil mix protection is needed when performing maintenance requiring entrance into the facility footprint	<ul style="list-style-type: none"> <li>• Minimize all loading in the facility footprint (foot traffic and other loads) to the degree feasible in order to prevent compaction of bioretention soils.</li> <li>• Never drive equipment or apply heavy loads in facility footprint.</li> <li>• Because the risk of compaction is higher during saturated soil conditions, any type of loading in the cell (including foot traffic) should be minimized during wet conditions.</li> <li>• Consider measures to distribute loading if heavy foot traffic is required or equipment must be placed in facility. As an example, boards may be placed across soil to distribute loads and minimize compaction.</li> <li>• If compaction occurs, soil must be loosened or otherwise rehabilitated to original design state.</li> </ul>
<b>Inlets/Outlets/Pipes</b>				
Splash block inlet	A		Water is not being directed properly to the facility and away from the inlet structure	Reconfigure/ repair blocks to direct water to facility and away from structure
Curb cut inlet/outlet	M during the wet season and before severe storm is forecasted	Weekly during fall leaf drop	Accumulated leaves at curb cuts	Clear leaves (particularly important for key inlets and low points along long, linear facilities)
Pipe inlet/outlet	A		Pipe is damaged	Repair/ replace
	W		Pipe is clogged	Remove roots or debris
	A, S		Sediment, debris, trash, or mulch reducing capacity of inlet/outlet	<ul style="list-style-type: none"> <li>• Clear the blockage</li> <li>• Identify the source of the blockage and take actions to prevent future blockages</li> </ul>
		Weekly during fall leaf drop	Accumulated leaves at inlets/outlets	Clear leaves (particularly important for key inlets and low points along long, linear facilities)
		A	Maintain access for inspections	<ul style="list-style-type: none"> <li>• Clear vegetation (transplant vegetation when possible) within 1 foot of inlets and outlets, maintain access pathways</li> <li>• Consultation with a landscape architect is recommended for removal, transplant, or substitution of plants</li> </ul>

**Table V-A.21: Maintenance Standards - Bioretention Facilities (continued)**

Maintenance Component	Recommended Frequency <sup>a</sup>		Condition when Maintenance is Needed (Standards)	Action Needed (Procedures)
	Inspection	Routine Maintenance		
Erosion control at inlet	A		Concentrated flows are causing erosion	Maintain a cover of rock or cobbles or other erosion protection measure (e.g., matting) to protect the ground where concentrated water enters the facility (e.g., a pipe, curb cut or swale)
Trash rack	S		Trash or other debris present on trash rack	Remove/dispose
	A		Bar screen damaged or missing	Repair/replace
Overflow	A, S		Capacity reduced by sediment or debris	Remove sediment or debris/dispose
Underdrain pipe	Clean pipe as needed	Clean orifice at least biannually (may need more frequent cleaning during wet season)	<ul style="list-style-type: none"> <li>Plant roots, sediment or debris reducing capacity of underdrain</li> <li>Prolonged surface ponding (see "Ponded water")</li> </ul>	<ul style="list-style-type: none"> <li>Jet clean or rotary cut debris/roots from underdrain(s)</li> <li>If underdrains are equipped with a flow restrictor (e.g., orifice) to attenuate flows, the orifice must be cleaned regularly.</li> </ul>
<b>Vegetation</b>				
Facility bottom area and upland slope vegetation	Fall and Spring		Vegetation survival rate falls below 75% within first two years of establishment (unless project O&M manual or record drawing stipulates more or less than 75% survival rate).	<ul style="list-style-type: none"> <li>Determine cause of poor vegetation growth and correct condition</li> <li>Replant as necessary to obtain 75% survival rate or greater. Refer to original planting plan, or approved jurisdictional species list for appropriate plant replacements (See Appendix 3 - Bioretention Plant List, in the <i>LID Technical Guidance Manual for Puget Sound</i>, <a href="#">(Hinman and Wulkan, 2012)</a>).</li> <li>Confirm that plant selection is appropriate for site growing conditions</li> <li>Consultation with a landscape architect is recommended for removal, transplant, or substitution of plants</li> </ul>
Vegetation (general)	As needed		Presence of diseased plants and plant material	<ul style="list-style-type: none"> <li>Remove any diseased plants or plant parts and dispose of in an approved location (e.g., commercial landfill) to avoid risk of spreading the disease to other plants</li> <li>Disinfect gardening tools after pruning to prevent the spread of disease</li> <li>See the <i>Pacific Northwest Plant Disease Management Handbook</i> <a href="#">(Pscheidt and Ocamb, 2016)</a> for information on disease recognition and for additional resources</li> <li>Replant as necessary according to recommendations provided for "facility bottom area and upland slope vegetation".</li> </ul>
Trees and shrubs		All pruning seasons (timing varies by species)	Pruning as needed	<ul style="list-style-type: none"> <li>Prune trees and shrubs in a manner appropriate for each species. Pruning should be performed by landscape professionals familiar with proper pruning techniques</li> <li>All pruning of mature trees should be performed by or under the direct guidance of an ISA certified arborist</li> </ul>
	A		Large trees and shrubs interfere with operation of the facility or access for maintenance	<ul style="list-style-type: none"> <li>Prune trees and shrubs using most current ANSI A300 standards and ISA BMPs.</li> <li>Remove trees and shrubs, if necessary.</li> </ul>
	Fall and Spring		Standing dead vegetation is present	<ul style="list-style-type: none"> <li>Remove standing dead vegetation</li> <li>Replace dead vegetation within 30 days of reported dead and dying plants (as practical depending on weather/planting season)</li> <li>If vegetation replacement is not feasible within 30 days, and absence of vegetation may result in erosion problems, temporary erosion control measures should be put in place immediately.</li> <li>Determine cause of dead vegetation and address issue, if possible</li> </ul>

**Table V-A.21: Maintenance Standards - Bioretention Facilities (continued)**

Maintenance Component	Recommended Frequency <sup>a</sup>		Condition when Maintenance is Needed (Standards)	Action Needed (Procedures)
	Inspection	Routine Maintenance		
				<ul style="list-style-type: none"> <li>If specific plants have a high mortality rate, assess the cause and replace with appropriate species. Consultation with a landscape architect is recommended.</li> </ul>
	Fall and Spring		Planting beneath mature trees	<ul style="list-style-type: none"> <li>When working around and below mature trees, follow the most current ANSI A300 standards and ISA BMPs to the extent practicable (e.g., take care to minimize any damage to tree roots and avoid compaction of soil).</li> <li>Planting of small shrubs or groundcovers beneath mature trees may be desirable in some cases; such plantings should use mainly plants that come as bulbs, bare root or in 4-inch pots; plants should be in no larger than 1-gallon containers.</li> </ul>
	Fall and Spring		Presence of or need for stakes and guys (tree growth, maturation, and support needs)	<ul style="list-style-type: none"> <li>Verify location of facility liners and underdrain (if any) prior to stake installation in order to prevent liner puncture or pipe damage</li> <li>Monitor tree support systems: Repair and adjust as needed to provide support and prevent damage to tree.</li> <li>Remove tree supports (stakes, guys, etc.) after one growing season or maximum of 1 year.</li> <li>Backfill stake holes after removal.</li> </ul>
Trees and shrubs adjacent to vehicle travel areas (or areas where visibility needs to be maintained)	A		Vegetation causes some visibility (line of sight) or driver safety issues	<ul style="list-style-type: none"> <li>Maintain appropriate height for sight clearance</li> <li>When continued, regular pruning (more than one time/ growing season) is required to maintain visual sight lines for safety or clearance along a walk or drive, consider relocating the plant to a more appropriate location.</li> <li>Remove or transplant if continual safety hazard</li> <li>Consultation with a landscape architect is recommended for removal, transplant, or substitution of plants</li> </ul>
Flowering plants		A	Dead or spent flowers present	Remove spent flowers (deadhead)
Perennials		Fall	Spent plants	Cut back dying or dead and fallen foliage and stems
Emergent vegetation		Spring	Vegetation compromises conveyance	Hand rake sedges and rushes with a small rake or fingers to remove dead foliage before new growth emerges in spring or earlier only if the foliage is blocking water flow (sedges and rushes do not respond well to pruning)
Ornamental grasses (perennial)		Winter and Spring	Dead material from previous year's growing cycle or dead collapsed foliage	<ul style="list-style-type: none"> <li>Leave dry foliage for winter interest</li> <li>Hand rake with a small rake or fingers to remove dead foliage back to within several inches from the soil before new growth emerges in spring or earlier if the foliage collapses and is blocking water flow</li> </ul>
Ornamental grasses (evergreen)		Fall and Spring	Dead growth present in spring	<ul style="list-style-type: none"> <li>Hand rake with a small rake or fingers to remove dead growth before new growth emerges in spring</li> <li>Clean, rake, and comb grasses when they become too tall</li> <li>Cut back to ground or thin every 2-3 years as needed</li> </ul>
Noxious weeds		M (March - October, preceding seed dispersal)	Listed noxious vegetation is present (refer to current county noxious weed list)	<ul style="list-style-type: none"> <li>By law, class A &amp; B noxious weeds must be removed, bagged and disposed as garbage immediately</li> <li>Reasonable attempts must be made to remove and dispose of class C noxious weeds</li> <li>It is strongly encouraged that herbicides and pesticides not be used in order to protect water quality; use of herbicides and pesticides may be prohibited in some jurisdictions</li> <li>Apply mulch after weed removal (see "Mulch")</li> </ul>
Weeds		M (March - October,	Weeds are present	<ul style="list-style-type: none"> <li>Remove weeds with their roots manually with pincer-type weeding tools, flame weeders, or hot water weeders as</li> </ul>

**Table V-A.21: Maintenance Standards - Bioretention Facilities (continued)**

Maintenance Component	Recommended Frequency <sup>a</sup>		Condition when Maintenance is Needed (Standards)	Action Needed (Procedures)
	Inspection	Routine Maintenance		
		preceding seed dispersal)		appropriate <ul style="list-style-type: none"> <li>Follow IPM protocols for weed management (see "Additional Maintenance Resources" section for more information on IPM protocols)</li> </ul>
Excessive vegetation		Once in early to mid- May and once in early- to mid-September	Low-lying vegetation growing beyond facility edge onto sidewalks, paths, or street edge poses pedestrian safety hazard or may clog adjacent permeable pavement surfaces due to associated leaf litter, mulch, and soil	<ul style="list-style-type: none"> <li>Edge or trim groundcovers and shrubs at facility edge</li> <li>Avoid mechanical blade-type edger and do not use edger or trimmer within 2 feet of tree trunks</li> <li>While some clippings can be left in the facility to replenish organic material in the soil, excessive leaf litter can cause surface soil clogging</li> </ul>
	As needed		Excessive vegetation density inhibits stormwater flow beyond design ponding or becomes a hazard for pedestrian and vehicular circulation and safety	<ul style="list-style-type: none"> <li>Determine whether pruning or other routine maintenance is adequate to maintain proper plant density and aesthetics</li> <li>Determine if planting type should be replaced to avoid ongoing maintenance issues (an aggressive grower under perfect growing conditions should be transplanted to a location where it will not impact flow)</li> <li>Remove plants that are weak, broken or not true to form; replace in-kind</li> <li>Thin grass or plants impacting facility function without leaving visual holes or bare soil areas</li> <li>Consultation with a landscape architect is recommended for removal, transplant, or substitution of plants</li> </ul>
	As needed		Vegetation blocking curb cuts, causing excessive sediment buildup and flow bypass	Remove vegetation and sediment buildup
<b>Mulch</b>				
Mulch		Following weeding	Bare spots (without mulch cover) are present or mulch depth less than 2 inches	<ul style="list-style-type: none"> <li>Supplement mulch with hand tools to a depth of 2 to 3 inches</li> <li>Replenish mulch per O&amp;M manual. Often coarse compost is used in the bottom of the facility and arborist wood chips are used on side slopes and rim (above typical water levels)</li> <li>Keep all mulch away from woody stems</li> </ul>
<b>Watering</b>				
Irrigation system (if any)		Based on manufacturer's instructions	Irrigation system present	Follow manufacturer's instructions for O&M
	A		Sprinklers or drip irrigation not directed/located to properly water plants	Redirect sprinklers or move drip irrigation to desired areas
Summer watering (first year)		Once every 1-2 weeks or as needed during prolonged dry periods	Trees, shrubs and groundcovers in first year of establishment period	<ul style="list-style-type: none"> <li>10 to 15 gallons per tree</li> <li>3 to 5 gallons per shrub</li> <li>2 gallons water per square foot for groundcover areas</li> <li>Water deeply, but infrequently, so that the top 6 to 12 inches of the root zone is moist</li> <li>Use soaker hoses or spot water with a shower type wand when irrigation system is not present                             <ul style="list-style-type: none"> <li>Pulse water to enhance soil absorption, when feasible</li> </ul> </li> </ul>

**Table V-A.21: Maintenance Standards - Bioretention Facilities (continued)**

Maintenance Component	Recommended Frequency <sup>a</sup>		Condition when Maintenance is Needed (Standards)	Action Needed (Procedures)
	Inspection	Routine Maintenance		
				<ul style="list-style-type: none"> <li>○ Pre-moisten soil to break surface tension of dry or hydrophobic soils/mulch, followed by several more passes. With this method, each pass increases soil absorption and allows more water to infiltrate prior to runoff</li> <li>• Add a tree bag or slow-release watering device (e.g., bucket with a perforated bottom) for watering newly installed trees when irrigation system is not present</li> </ul>
Summer watering (second and third years)		Once every 2-4 weeks or as needed during prolonged dry periods	Trees, shrubs and groundcovers in second or third year of establishment period	<ul style="list-style-type: none"> <li>• 10 to 15 gallons per tree</li> <li>• 3 to 5 gallons per shrub</li> <li>• 2 gallons water per square foot for groundcover areas</li> <li>• Water deeply, but infrequently, so that the top 6 to 12 inches of the root zone is moist</li> <li>• Use soaker hoses or spot water with a shower type wand when irrigation system is not present                             <ul style="list-style-type: none"> <li>○ Pulse water to enhance soil absorption, when feasible</li> <li>○ Pre-moisten soil to break surface tension of dry or hydrophobic soils/mulch, followed by several more passes. With this method, each pass increases soil absorption and allows more water to infiltrate prior to runoff</li> </ul> </li> </ul>
Summer watering (after establishment)		As needed	Established vegetation (after 3 years)	<ul style="list-style-type: none"> <li>• Plants are typically selected to be drought tolerant and not require regular watering after establishment; however, trees may take up to 5 years of watering to become fully established</li> <li>• Identify trigger mechanisms for drought-stress (e.g., leaf wilt, leaf senescence, etc.) of different species and water immediately after initial signs of stress appear</li> <li>• Water during drought conditions or more often if necessary to maintain plant cover</li> </ul>
<b>Pest Control</b>				
Mosquitoes	B, S		Standing water remains for more than 3 days after the end of a storm	<ul style="list-style-type: none"> <li>• Identify the cause of the standing water and take appropriate actions to address the problem (see "Ponded water")</li> <li>• To facilitate maintenance, manually remove standing water and direct to the storm drainage system (if runoff is from non pollution-generating surfaces) or sanitary sewer system (if runoff is from pollution-generating surfaces) after getting approval from sanitary sewer authority.</li> <li>• Use of pesticides or <i>Bacillus thuringiensis israelensis</i> (Bti) may be considered only as a temporary measure while addressing the standing water cause. If overflow to a surface water will occur within 2 weeks after pesticide use, apply for coverage under the Aquatic Mosquito Control NPDES General Permit.</li> </ul>
Nuisance animals	As needed		Nuisance animals causing erosion, damaging plants, or depositing large volumes of feces	<ul style="list-style-type: none"> <li>• Reduce site conditions that attract nuisance species where possible (e.g., plant shrubs and tall grasses to reduce open areas for geese, etc.)</li> <li>• Place predator decoys</li> <li>• Follow IPM protocols for specific nuisance animal issues (see "Additional Maintenance Resources" section for more information on IPM protocols)</li> <li>• Remove pet waste regularly</li> <li>• For public and right-of-way sites consider adding garbage cans with dog bags for picking up pet waste.</li> </ul>
Insect pests	Every site visit associated with		Signs of pests, such as wilting leaves, chewed leaves and bark, spotting or other indicators	<ul style="list-style-type: none"> <li>• Reduce hiding places for pests by removing diseased and dead plants</li> <li>• For infestations, follow IPM protocols (see "Additional Maintenance Resources" section for more information on IPM</li> </ul>

**Table V-A.21: Maintenance Standards - Bioretention Facilities (continued)**

Maintenance Component	Recommended Frequency <sup>a</sup>		Condition when Maintenance is Needed (Standards)	Action Needed (Procedures)
	Inspection	Routine Maintenance		
	vegetation management			protocols)
<p>Note that the inspection and routine maintenance frequencies listed above are recommended by Ecology. They do not supersede or replace the municipal stormwater permit requirements for inspection frequency required of municipal stormwater permittees for "stormwater treatment and flow control BMPs/facilities".</p> <p><sup>a</sup> Frequency: A = Annually; B = Biannually (twice per year); M = Monthly; W = At least one visit should occur during the wet season (for debris/clog related maintenance, this inspection/maintenance visit should occur in the early fall, after deciduous trees have lost their leaves); S = Perform inspections after major storm events (24-hour storm event with a 10-year or greater recurrence interval).</p> <p>IPM - Integrated Pest Management ISA - International Society of Arboriculture</p>				

**Table V-A.22: Maintenance Standards - Permeable Pavement**

Component	Recommended Frequency <sup>a</sup>		Condition when Maintenance is Needed (Standards)	Action Needed (Procedures)
	Inspection	Routine Maintenance		
<b>Surface/Wearing Course</b>				
Permeable Pavements, all	A, S		Runoff from adjacent pervious areas deposits soil, mulch or sediment on paving	<ul style="list-style-type: none"> <li>• Clean deposited soil or other materials from permeable pavement or other adjacent surfacing</li> <li>• Check if surface elevation of planted area is too high, or slopes towards pavement, and can be regraded (prior to regrading, protect permeable pavement by covering with temporary plastic and secure covering in place)</li> <li>• Mulch and/or plant all exposed soils that may erode to pavement surface</li> </ul>
Porous asphalt or pervious concrete		A or B	None (routine maintenance)	<p>Clean surface debris from pavement surface using one or a combination of the following methods:</p> <ul style="list-style-type: none"> <li>• Remove sediment, debris, trash, vegetation, and other debris deposited onto pavement (rakes and leaf blowers can be used for removing leaves)</li> <li>• Vacuum/sweep permeable paving installation using: <ul style="list-style-type: none"> <li>◦ Walk-behind vacuum (sidewalks)</li> <li>◦ High efficiency regenerative air or vacuum sweeper (roadways, parking lots)</li> <li>◦ ShopVac or brush brooms (small areas)</li> </ul> </li> <li>• Hand held pressure washer or power washer with rotating brushes Follow equipment manufacturer guidelines for when equipment is most effective for cleaning permeable pavement. Dry weather is more effective for some equipment.</li> </ul>
		A <sub>b</sub>	Surface is clogged: Ponding on surface or water flows off the permeable pavement surface during a rain event (does not infiltrate)	<ul style="list-style-type: none"> <li>• Review the overall performance of the facility (note that small clogged areas may not reduce overall performance of facility)</li> <li>• Test the surface infiltration rate using ASTM C1701 as a corrective maintenance indicator. Perform one test per installation, up to 2,500 square feet. Perform an additional test for each additional 2,500 square feet up to 15,000 square feet total. Above 15,000 square feet, add one test for every 10,000 square feet.</li> <li>• If the results indicate an infiltration rate of 10 inches per hour or less, then perform corrective maintenance to restore permeability. To clean clogged pavement surfaces, use one or combination of the following methods:</li> </ul>